

Fig. 1

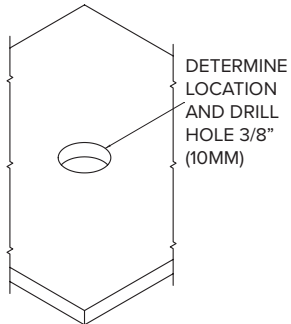

Fig. 2

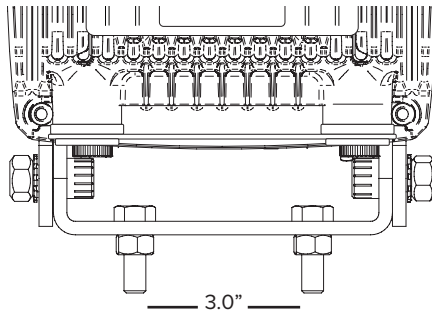
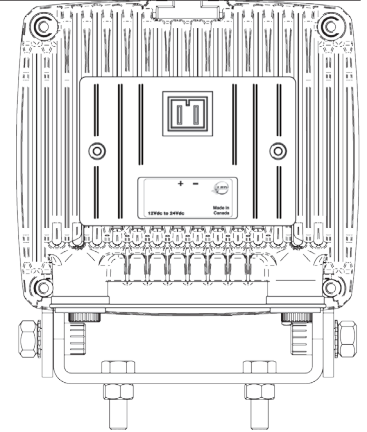
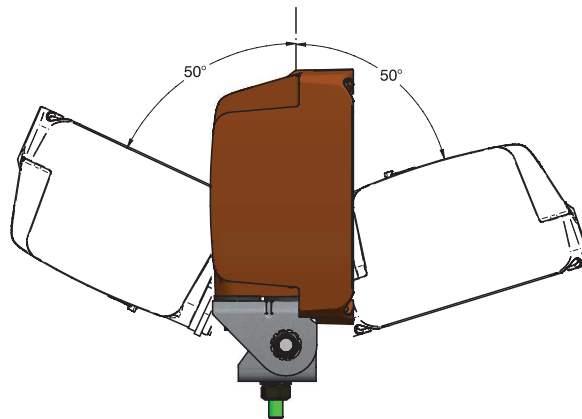
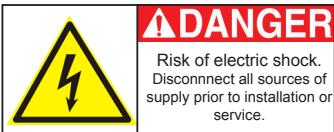

Fig. 3



+12V TO +24V

ELECTRICAL CONNECTION
DEUTSCH CONNECTOR



NOTE: LIGHTS MUST BE CONNECTED TO ELECTRICAL CONDUCTORS THAT ARE SIZED PROPERLY & FUSED.



Light must be fused appropriately in all instances. If you are in doubt, contact Jameson at 800.346.1956.
NOTE: Improperly fused/installed product will invalidate the warranty.

Warranty

Jameson HDI Lights carry a warranty against any defect in material and workmanship for a period of three (3) years from date of shipment unless failure is due to misuse or improper application. Jameson shall in no event be responsible or liable for modifications, alterations, misapplications or repairs made to its products by purchaser or others. This warranty is limited to repair or replacement of the product and does not include reimbursement for shipping or other expenses incurred. Jameson disclaims any other express or implied warranty.