



## **COMPLETING THE CONNECTION:**

Effectively Grounding Your Electric Fence for  
Maximum Shock Value

---

[www.PowerWizardInc.com](http://www.PowerWizardInc.com) | Toll-free: 1-800-866-2161

© 2011 AgraTronix, LLC. All Rights Reserved.

## Power Wizard Mission Statement

We believe in providing the best possible quality products and customer service for cattlemen, ranchers and weekend farmers. We strive to be the leading provider of fence chargers and fence energizer accessories so that our customers can consistently protect their dairy cows, cattle and other livestock without worrying about their safety.

## CONTENTS

What is Grounding and Why is it Important? .....	3
Ground Conditions: Moist and Wet or Dry and Rocky? .....	3
How to Effectively Ground Your Electric Fence .....	3
Locating Your Grounding System .....	4
Installing the Grounding System .....	5
Testing Your Electrical Current .....	5
Most Common Grounding Issues .....	7
Conclusion .....	7

*“Completing the Connection: Effectively Grounding Your Electric Fence for Maximum Shock Value”* is brought to you by Power Wizard electric fence energizers.

For more information about Power Wizard electric fence energizers, visit [www.PowerWizardInc.com](http://www.PowerWizardInc.com) or call customer service at 1-800-866-2161.

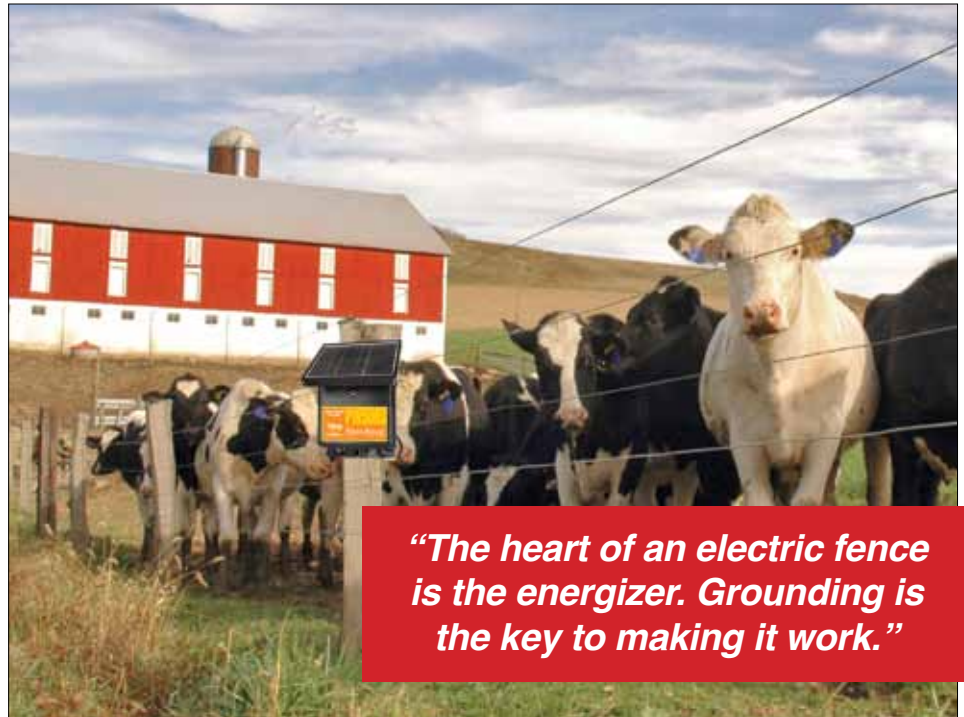

***“The heart of an electric fence is the energizer. Grounding is the key to making it work.”***

## Notes:

Without effective grounding the circuit cannot be complete and the fence becomes ineffective as a method of containing cattle or keeping out predators.

*"For your fence to function correctly, your earth (ground) system must be perfect. But very few are, despite the instructions provided with most energizers."*<sup>1</sup>

Footnotes:  
<sup>1</sup> "Make a Well-Grounded (Earthed) Fence," Vaughn Jones, February 1998

## DIAGRAM 1 Ground System Installation

1. 10-14 gauge galvanized fence wire.
2. Ground rods 4'-6' long by ½" (or more) in diameter, galvanized steel rods.

**IMPORTANT: Avoid SANDY, DRY and ROCKY soil.**

## WHAT IS GROUNDING AND WHY IS IT IMPORTANT?

The safest, most economical and effective way to contain your dairy cows or beef cattle is with an electric fence powered with a high quality fence charger, such as the Power Wizard energizer.

A cow that encounters an electric fence receives one pulse of electricity per second, providing the fence has been effectively grounded. An electric pulse occurs when the cow comes in contact with both the ground and the wire. When this happens the circuit is complete and the cow receives an electrical shock.

### Ground Conditions: Moist and Wet or Dry and Rocky?

Before you start to create an effective grounding system for your cattle ranch, consider the ground conditions. To be effective, the rods should be inserted into ground that is continually moist. If your ranch consists of dry or rocky soil, seek an area of your farm that has some degree of moisture or that can be moistened during drought conditions. Or consider adding a Earth Wire Return System.

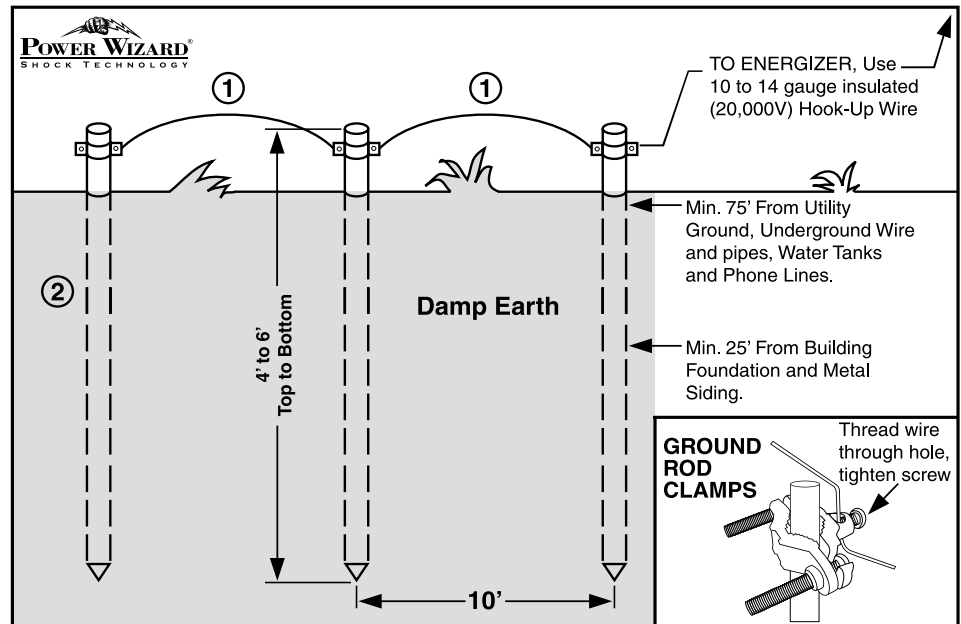

### How to Effectively Ground Your Electric Fence

Grounding your electric fence requires the installation of a ground system that is positioned within 75 feet of your Power Wizard fence charger.

#### What is a Ground System?

The "ground system" is a series of highly conductive rods driven into the soil and then connected by wire to the ground terminal of your fence energizer. The ground system collects electrons from the soil to complete the circuit needed for delivering an effective shock to your animals.

Locate the ground system a minimum of 75 feet away from:

- Utility company (electric, gas, water) ground system
- Underground water pipe
- Metal water tanks

## DIAGRAM 2 Energizer Installation

1. Insulated hook-up wire (20,000V)
2. Galvanized fence wire
3. 6' galvanized ground rod, ½" diameter or more
4. Ground clamps
5. Power supply – use power supply specified by label on energizer only
6. Ground rods MUST be 25' minimum from building foundation

### Please Note:

The hot is either indicated by a red knob or a lightning bolt symbol (⚡) and the ground is indicated by a black knob or an arrow symbol (↔).

## LOCATING YOUR GROUNDING SYSTEM

Locate an area of soil for placing ground rods that contains good conductive earth (not sandy or rocky). Soil that is moist throughout the year is best. The ground system should be located within 75 feet of your fence energizer and at least 25 feet from buildings with metal siding.

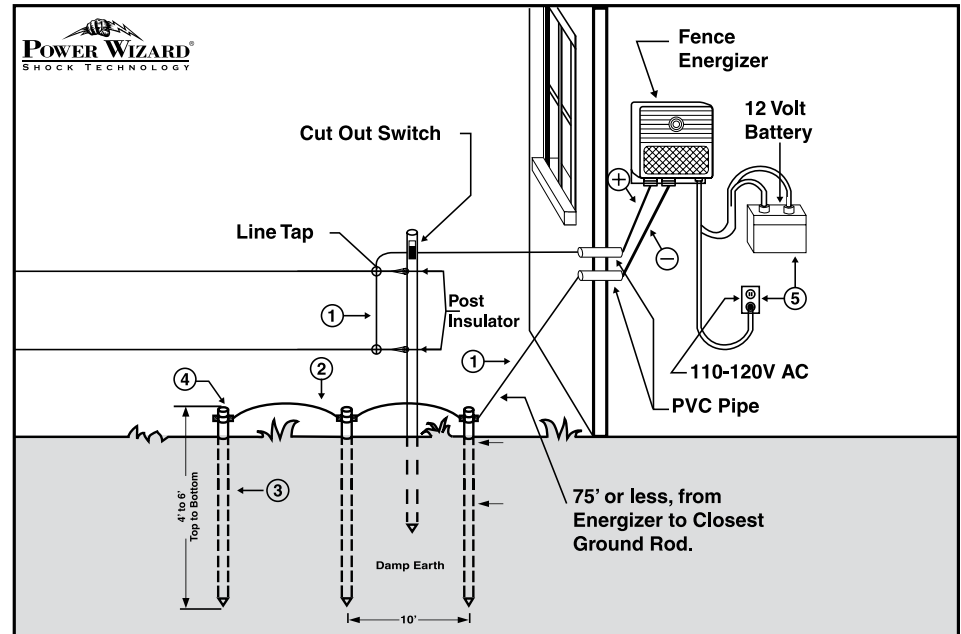

## Troubleshooting Ground Conditions

If the soil is moist during most of the year but suffers from period of dryness in the hot, summer months, it is possible to water the grounding system to keep a strong electrical connection.

**Tip for Dry Soil:** Farms with extremely dry ground conditions can include a bentonite mix to their grounding system to help absorb moisture. Create a paste or gel-like consistency from powered bentonite and water and pour down a 3 inch diameter or larger holes and insert the ground poles in the center.<sup>2</sup>

**Add Grounding Rods:** Another solution for rocky, dry or sandy soil is to add more grounding rods in the grounding system. A standard grounding system contains three, 4 to 6 foot by ½ inch galvanized grounding rods 10 feet apart. For dry soil, add an additional grounding rod to increase the energy connection that completes the circuit between the fence energizer, the ground and the cow.

One of the existing strands of fence can be grounded but a better solution would be to run a bare galvanized wire along the fence line and just below the surface of the dirt. Run a grounding wire parallel between the electric wires and drive a 6-foot galvanized steel or copper rod every 1,300 feet. By using this system to ground the electrical fence, the electricity is able to effectively shock the cow without the current traveling underground. The wire should be attached to each post for the best results.

### Footnotes:

<sup>2</sup> "How to Mix Bentonite" Finn McCuhil, May, 2010  
Earth Wire Return System: The third solution for rocky or frozen ground conditions is to run a ground wire on the actual fence or just beneath the surface of the soil.

## INSTALLING THE GROUND SYSTEM

### Supplies Needed:

- Three 4'-6' long x ½" (or more) in diameter galvanized steel rods (or more if poor ground conditions)
- 10-14 gauge galvanized, insulated (20,000V) fence wire
- Sledge hammer or ground rod driver
- Ground clamps, one for each rod
- 3 or 4 steel stakes
- Digital volt meter made for electric fences
- 12" metal stake

**DIAGRAM 3**  
*Ground Return System*

### WARNING:

Never use an existing grounding rod that is connected to another electrical device or use a water line to ground your electric fence.

Drive three, 4 to 6 foot by ½ inch (minimum), galvanized ground rods 10 feet apart in a straight line or a triangle pattern in the selected ground area. Leave 6 inches above the ground for securing ground clamps. The ground rod may be driven in at an angle if necessary.

Connect the ground rods, in a series, with one piece of continuous 10 to 14 gauge galvanized wire. The ground hook-up wire should be equal to or larger than the diameter of the fence line wire. See "Figure" below.

- (a) Galvanized fence wire  
(b) Ground rods

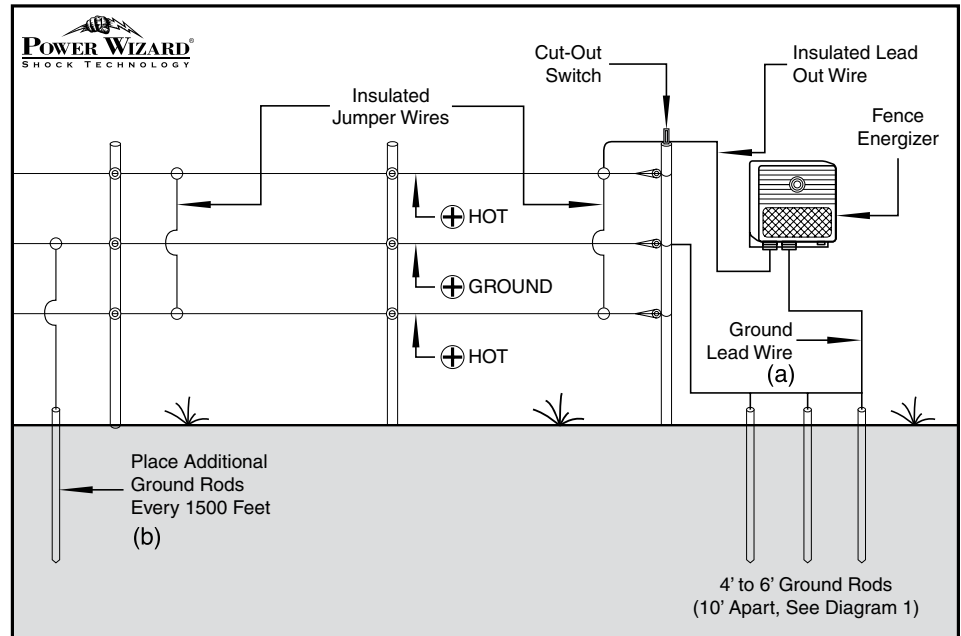

### Testing Your Electrical Current

The performance of your Power Wizard fence charger's ability to keep your cows, cattle and other livestock safe and contained relies on the effectiveness of your ground system.

The ground system is a critical part of the connection that completes the circuit between the electric fence and your cattle. Verifying that your ground system is working is a "must-do" stage of the installation of your electric fence.

### Verify Your Ground System Works

1. Unplug your Power Wizard fence energizer.
2. Place the fence under heavy load by "shorting" the fence as follows: At a location on the fence at least 100 yards from the energizer, lean 3 or 4 steel stakes or unpainted T-posts against the "hot" wire of the fence. Alternatively, some people have found a successful method is to push several pieces of fence wire into the earth and wrap the opposite ends around the hot wire.

## DIAGRAM 4 Testing the Ground System

### Test periodically

Once your ground system is installed and the electrical current is verified you will still need to periodically check to make sure the level of electrical current is effective enough to contain your cows.

Check your ground system condition with a volt meter once during the driest period and once during the wet season each year to insure adequate grounding of your electric fence.

During dry seasons or during seasons when there is excessive growth or vegetation on your fence line, it may be necessary to upgrade your ground system by adding ground rods.

## INSTALLING THE GROUND SYSTEM (CONT.)

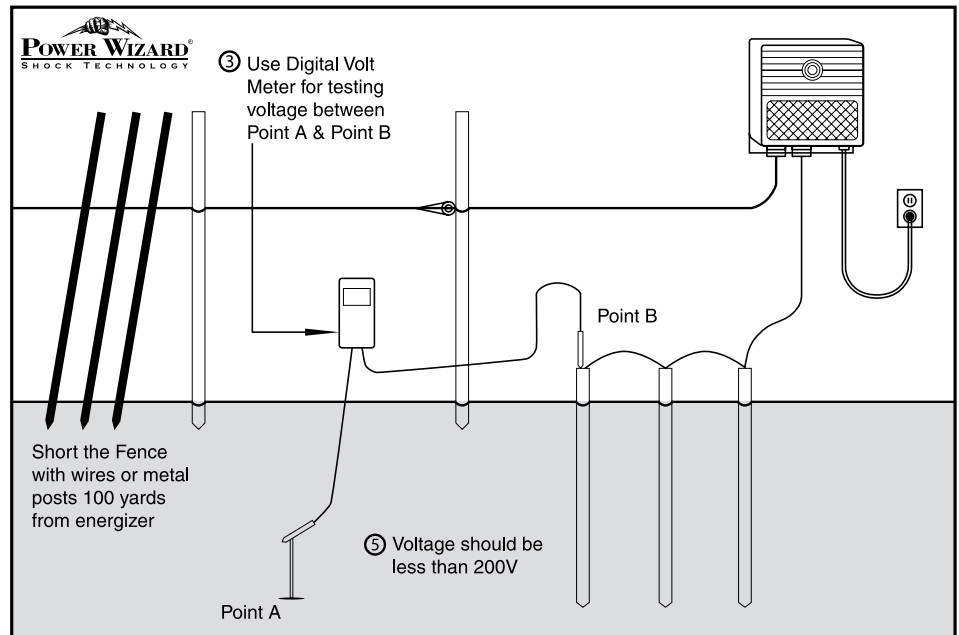

3. Plug the Power Wizard fence energizer in and check the fence line voltage with a digital volt meter. You want to see that the voltage has dropped below 2,000V due to shorting the fence. On some high powered fence energizers you may not be able to short the fence below 2,000V. However, you can still test them at a higher voltage.
4. Continue to short the fence by leaning steel posts or by making wire connections to ground at 100 yards distance or more from energizer until the fence line voltage drops below 2,000V.
5. You are now ready to test the energizer ground system. Connect one lead of the digital volt meter to a 12 inch metal stake driven into the ground 3 feet away from the last fence energizer ground rod. Connect the second lead to the ground rod furthest from the energizer. The voltage reading should ideally be zero or no more than 200V.
6. If the digital volt meter reading is under 200V, your ground system is adequate and you will get near maximum performance from your electric fence energizer.
7. If the reading is above 200V, then your ground system needs improvement.  
**You must:**
  - a. Add more ground rods connected in series, ten feet apart and/or
  - b. Move your ground system to moist soil until the ground system voltage is below 200V.

## Notes:

Make sure you test your electric fence with a digital volt meter on a routine basis. This is especially important when vegetation is high and touches the fence or when the ground is very dry or very damp.

## MOST COMMON GROUNDING ISSUES

The most common misconception by farmers, ranchers and weekend hobbyists is that the grounding process isn't important.

The cow completes the circuit so that the electrons flow from the Power Wizard fence energizer, through the soil to the grounding rods and up into the cow's legs to where the cow is touching the fence with its nose or body, producing an electrical shock.

Therefore, the effectiveness of the ground system is extremely important.

### Following are some common grounding issues:

1. There is a bad wire connection to the ground wire. Check to make sure the wire is securely fastened and isn't frayed.
2. The dry soil condition of the farm requires additional grounding rods.
3. The wrong type of rod was used for the grounding, i.e. pipe or rebar. It needs to be galvanized steel at least 4 to 6 feet long.
4. The rods weren't long enough. In the case of dry soil, it may require 6-8 feet of galvanized steel to reach a moist area of ground.
5. The ground conditions changed and due to extreme draught or heavy vegetation, additional rods need to be added.
6. The wrong type of wire was used. Using household or industrial cables made for only 400V are not enough to support the system. Make sure you use 10 to 14 gauge insulated lead-out wire rated at 20,000V.

## Conclusion

Creating and testing your ground system is a critical step to ensuring your Power Wizard fence charger provides the necessary jolt of energy to get your cow's attention and keep them from ramming or damaging the fence line or themselves.

### Four main points to remember:

1. It is the connection of the cow with the ground and the hot wire that completes the circuit to allow an effective shock to be delivered.
2. Install the ground system on a consistently moist area of your farm within 75 feet of the Power Wizard fence energizer.
3. Use the proper rods and wire when building your ground system.
4. Test periodically to ensure the electrical connection is effective during dry, damp and high vegetation seasons.

## POWER WIZARD® ELECTRIC FENCE ENERGIZERS

### Engineering and Technology Leaders in the Fence Energizer Industry

Power Wizard fence chargers are an environmentally safe, cattle-friendly, reliable, effective solution for energized fences. We offer a wide range of fence chargers to keep valuable livestock in and keep predators outside the fence.

Power Wizard products include plug-in, solar and battery-powered electric fence energizers. The Power Wizard brand of energizers is known for providing the longest lasting, low-impedance energizer available today. Power Wizard energizers use technology designed to set the industry standard for high performance under the toughest of conditions.

### Power Wizard Shock Technology Works for Every Farm Size

We offer over 20 different types of fence energizers, all backed with our 3-year warranty. Our fence energizers are designed to meet the varied needs from cattle ranchers, dairy farmers, small hobby farmers and those raising specialty animals, such as alpacas or llamas.

To determine which electric fence energizer is right for your needs, check out the [Energizer Selection Guide](#) at [www.PowerWizardInc.com](http://www.PowerWizardInc.com).

### Power Wizard's Warranty Speaks Volumes

We believe in our products and we trust you will too, that's why we back all of our fence energizers with a **THREE YEAR WARRANTY** which includes protection from lightning strikes. If for some reason you are not happy with the performance of a Power Wizard energizer, simply call our Customer Service department.



For more information about  
Power Wizard brand of energizers,  
Visit [www.PowerWizardInc.com](http://www.PowerWizardInc.com) or  
Call customer service at 1-800-866-2161.