



pond boss® PRO

1/2 HP Floating Fountain with Lights

ITEM #PROFTN51003L

REMINDER
CALL 1-888-755-6750
BEFORE RETURNING TO STORE.



Questions, problems, missing parts? Before returning to your retailer, call our customer service department at 1-888-755-6750, 8 a.m.-6 p.m., EST, Monday-Friday, or email us at customer care@thepondboss.net. Or visit our website www.thepondboss.net.

PACKAGE CONTENTS

Part	Description	Quantity
A	Floating Attachment Assembly with LED lights	1
B	Trumpet Nozzle	1
C	Single Tier Nozzle	1
D	3 Tier Nozzle	1
E	Transformer	1
F	Sensor	1
G	Pump with cord for LED light	1
H	Tether Line	1
I	Ground Anchor	3

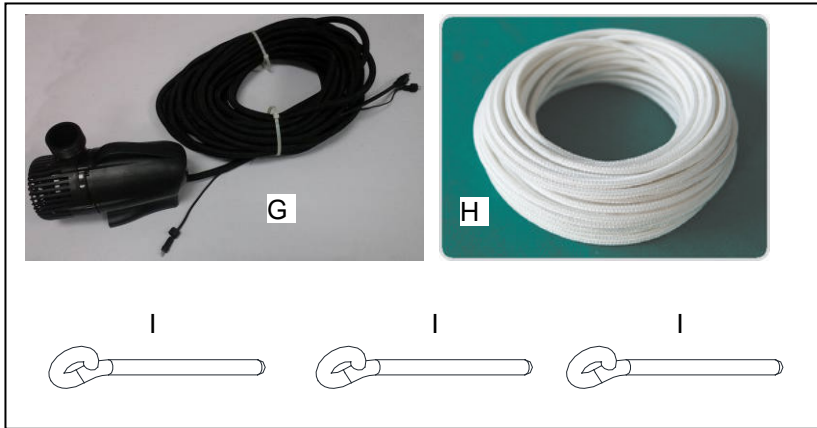
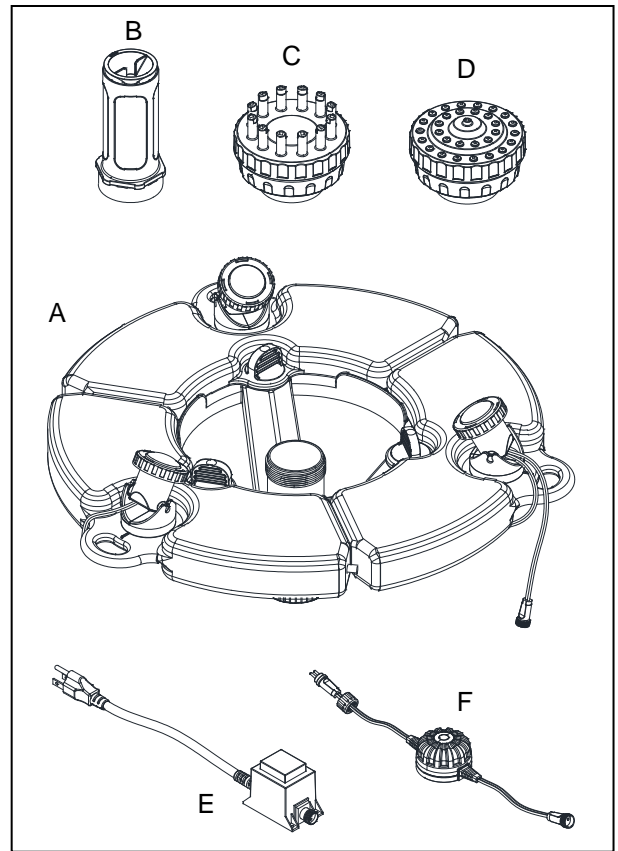

WARNINGS AND CAUTIONS

WARNING

- Risk of electrical shock. This fountain is supplied with a grounding conductor and grounding-type attachment plug for pump. To reduce the risk of electric shock, be certain that it is connected only to a properly grounded, grounding-type receptacle.
- Do not exceed the voltage shown on the pump and transformer.
- Always disconnect fountain from the power source before beginning any maintenance or work on the pump.
- Inspect cord for damage before installation and/or maintenance. Replace the entire fountain assembly if damage is found.
- Do not remove the grounding pin from the power cord plug.
- Risk of electrical shock – This fountain has not been investigated for use in swimming pool or marine areas.



PLEASE CALL 1-888-755-6750 BEFORE RETURNING TO THE STORE.
WWW.THEPONDBOSS.NET

CAUTION

- This fountain has been evaluated for use with fresh water only.
- Use a proper power source as indicated on the pump and transformer label.
- Keep the cord away from high temperatures or other heat sources.
- Do not let the fountain pump run dry. Pump must be completely submerged for proper operation and cooling.
- Operate in fresh water only. Avoid heavily chlorinated water and water with high pH levels.
- Do not pull the fountain by its power cord.

PREPARATION

Before beginning assembly or operation of product, make sure all parts are present. Compare parts with package contents list and diagram above. If any part is missing or damaged, do not attempt to assemble, install or operate the product. Contact customer service for replacement parts.

- Estimated Assembly Time: 10 minutes
- Tools required for assembly: knife.

ASSEMBLY INSTRUCTIONS

1. Remove assembled fountain from packaging and connect pump to floating attachment assembly by screw the nut on floating attachment assembly to the outlet of pump. Fig. 1

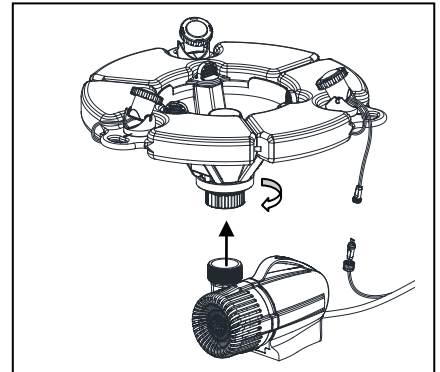

Fig. 1

2. Choose a fountain head for the desired water effect, and assemble your choice as shown in Fig. 2

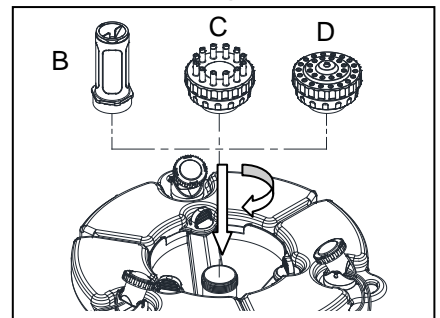

Fig. 2

3. Connect the light to the cord by pushing the plug into the light socket until it is firmly seated. Hand tighten the nut from the plug to the socket. Fig. 3

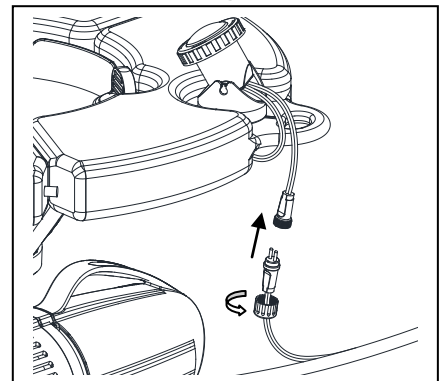

Fig. 3



PLEASE CALL 1-888-755-6750 BEFORE RETURNING TO THE STORE.
WWW.THEPONDBOSS.NET

- Unwind power cord and connect another side of the cord for LED light to the sensor by pushing the plug into the sensor socket until it is firmly seated. Hand tighten the nut from the plug to the socket. Fig. 4

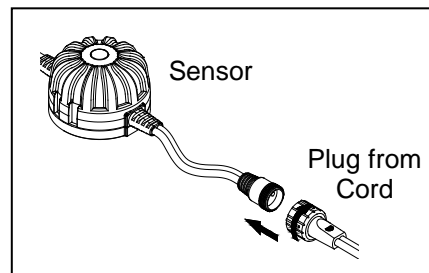

Fig. 4

- Connect the sensor to the transformer by pushing the plug into the transformer socket until it is firmly seated. Hand tighten the nut from the plug to the socket. Fig. 5

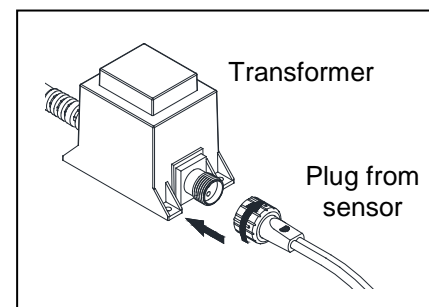

Fig. 5

- Use knife cut 3pcs tether Line, line length depend on you lake size, attach one side of line to each of the three loops Fig. 6

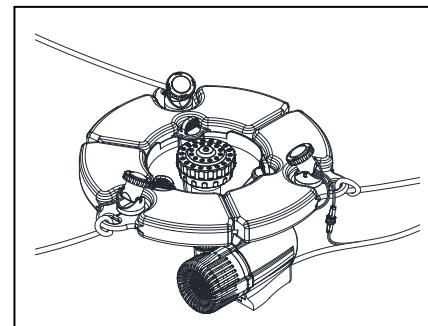

Fig. 6

- Place the fountain into the water and tether it with supplied line and ground anchors into desired location. Fig. 7

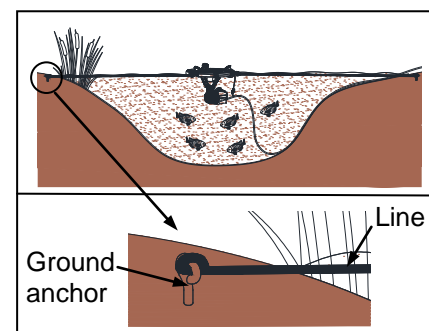

Fig. 7

- Plug pump and transformer into GFCI rated outlet. Fig. 8

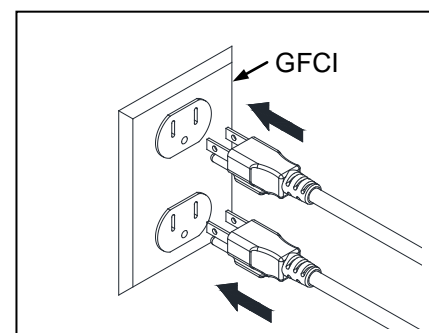

Fig. 8



PLEASE CALL 1-888-755-6750 BEFORE RETURNING TO THE STORE.
WWW.THEPONDBOSS.NET

CARE AND MAINTENANCE

- Regular cleaning of the fountain may be necessary depending upon the environment in which it is operated. Clean the fountain when a drop in visual performance is detected.
- Before cleaning, always disconnect the pump and transformer from the power source.
- Remove nozzle from the fountain and clean in warm, soapy water.
- Remove the pump from the fountain, disassemble the screen and remove the impeller housing to expose the impeller assembly. Remove the impeller assembly by pulling on the back round plate behind the impeller.

NOTE: This pump uses a very strong magnet to achieve superior performance. When removing the impeller assembly there will be considerable magnetic force resisting the extraction of the impeller assembly. This is normal. Likewise when replacing the impeller assembly there will be a strong magnetic force pulling the assembly into the pump to potentially cause injury to fingers and in rare cases damaging the ceramic shaft or rear bearing. Use thick gloves when replacing the impeller assembly.

Use a soft cloth or brush to clean the impeller assembly and the inside of the impeller housing. Refer to the diagram in the replacement parts list.

- Clean lights with a soft brush and non abrasive cleaner.

TROUBLESHOOTING

If the fountain fails to operate:

- Check to make sure the power cord is plugged in and the pump is getting power.
- Check the fountain nozzle and for kinks or obstructions.
- Remove the inlet screen and/or pump cover of pump, and impeller housing to expose the impeller. Turn the impeller to ensure that it is not broken or jammed. Also check to make sure that the ceramic shaft or bearings are not broken.

If the performance of the pump is not satisfactory or the fountain does not flow evenly:

- Check to make sure the pump is completely submerged in water.
- Check to make sure the impeller and the housing are clean.
- Check to make sure the fountain nozzle is clean.

If the lights do not turn on

- Check to make sure the transformer is plug in power outlet.
- If transformer is plug in power outlet, check that lights are getting power by testing another appliance in the same power outlet.
- The light is designed to turn on when it gets dark, and turn off when it gets light. To activate the light during daylight hours, cover the sensor. If lights do not turn off during daytime, check sensor. Make sure the sensor faces up and is not covered by dirt or debris.
- Check to see if the power cord is not cut or damaged.



**PLEASE CALL 1-888-755-6750 BEFORE RETURNING TO THE STORE.
WWW.THEPONDBOSS.NET**

REPLACEMENT PARTS LIST

For replacement parts, call our customer service department at 1-888-755-6750, 8 a.m.-6 p.m., EST, Monday-Friday, or email us at customercare@thepondboss.net.

Part	Description
B	Trumpet Nozzle
C	Single Tier Nozzle
D	3 Tier Nozzle
E	Transformer
F	Sensor
G	Pump with cord for LED light
H	Tether Line
I	Ground Anchor
J	Led light set
K	Light cord Extension
L	Float bolt
M	1/3 float attachment
N	Washer
O	Screw 1
P	Fountain Support
Q	Adapter
R	Locking ring
S	Screw 2
T	Screen
U	Impeller housing
V	Impeller Assembly
W	O-ring

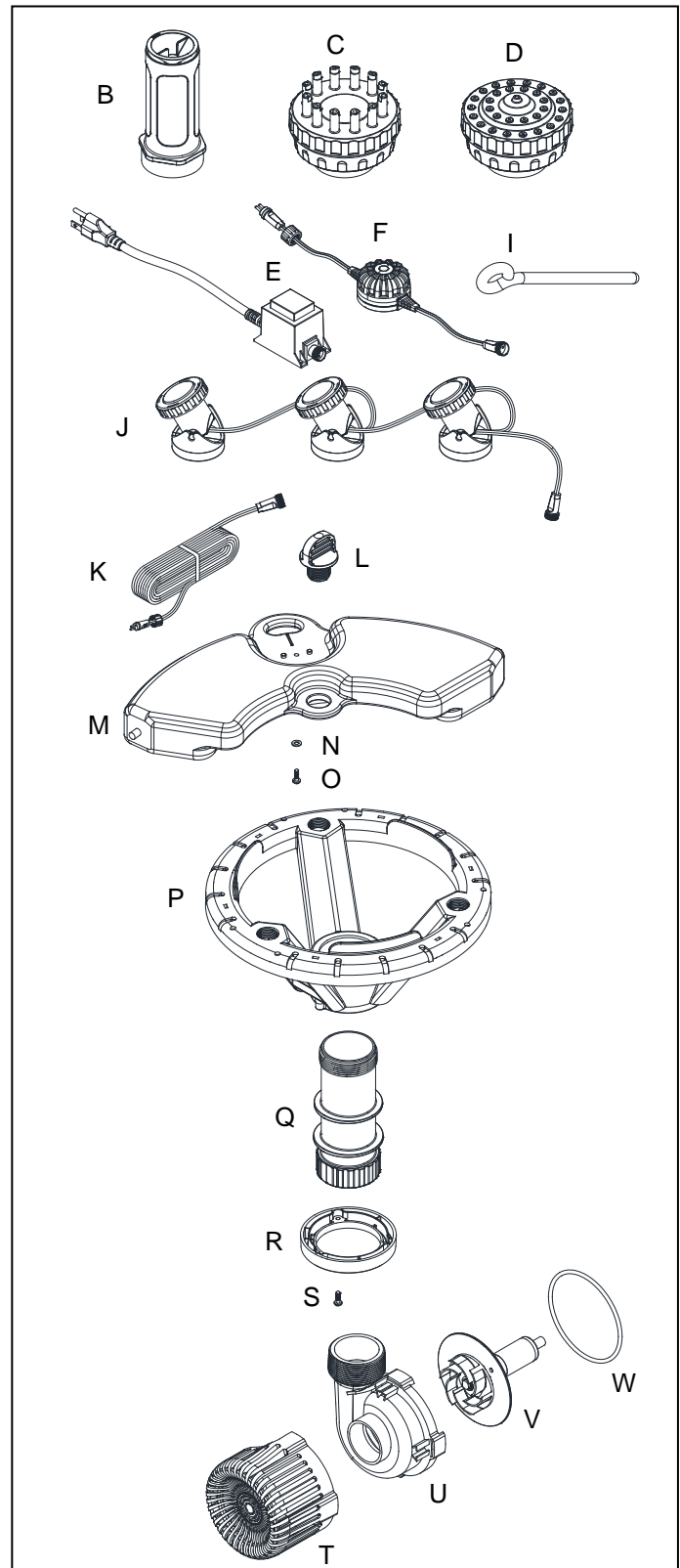
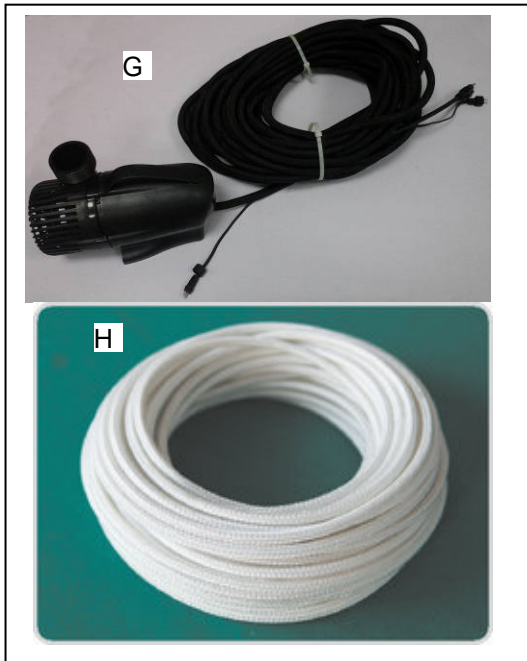

Printed in China



PLEASE CALL 1-888-755-6750 BEFORE RETURNING TO THE STORE.
WWW.THEPONDBOSS.NET

LIMITED WARRANTY

All pumps and electrical products are warranted to the user against defective material and workmanship, under normal working conditions. This warranty period begins on the date of purchase by the original purchaser.

Unless otherwise specified all pond boss® electrical products are warranted to the user against defective material and workmanship, under normal working conditions for 1 year from the date of purchase.

- Fountain pumps are warranted for 2 years.
- Pond pumps are warranted for 3 years.
- Waterfall pumps are warranted for 5 years.
- All pond boss® liners are warranted to the user against defective workmanship, under normal working conditions for 20 years from the date of purchase.
- All other pond boss® products are warranted to the user against defective material and workmanship, under normal working conditions for 90 days.

Application

Warranty covers only properly installed and maintained units. Any damage to the cord or modification to the unit will invalidate the warranty. Pump warranty is limited to applications pumping fresh water in a pond or fountain only. Other liquid applications or extreme temperature uses must be approved in writing by the manufacturer. Receipt and product date code are required for warranty claims.

Warranty Claim

Warranty claims must be made by calling customer service (at 1-888-755-6750). If the item is determined to be defective, you will be given authorization to return the defective part(s), freight pre-paid, along with proof of purchase.

Disposition

The manufacturer will make a good faith effort for prompt disposition regarding all warranty claims. Returned product will be inspected to determine cause of failure before warranty is applied. Warranty does not cover any costs associated with the shipping, handling, installation or removal of products or parts subject to this warranty. For products damaged in transit, a claim should be filed with the carrier.

Disclaimer

Any oral statements made about the product by the seller, the manufacturer, the representatives, or any other parties do not constitute warranties, should not be relied upon by the user, and are not part of the contract for sale. The seller's and manufacturer's only obligation, and buyer's only remedy shall be for the manufacturer to either replace and/or repair at the manufacturer's sole discretion, the product as described above. Neither seller nor the manufacturer shall be liable for injury, loss or damages for lost profits, lost sales, injury to person or property, or any other incidental or consequential loss arising from any cause whatsoever, no matter whether based upon warranty, contract, negligence or other misuse, and the buyer and user agree that no other remedy shall be available to them. Before using, the buyer and user shall determine the suitability of the product for the intended use, and assume all risk and liability whatsoever in connection therewith. The warranty and remedy described in this limited warranty is an exclusive warranty and remedy in lieu of any other warranty or remedy expressed or implied. All other warranties and remedies are hereby expressly excluded, including but not limited to any implied warranty of merchantability of fitness for any particular purpose. This warranty gives the buyer and user specific legal rights, and buyer and user may also have other rights which vary from state to state. Some states do not allow exclusions or limitations of incidental or consequential damages, so the above limitations or exclusions may not apply to you.

REMINDER
CALL 1-888-755-6750
BEFORE RETURNING TO STORE.



PLEASE CALL 1-888-755-6750 BEFORE RETURNING TO THE STORE.
WWW.THEPONDBOSS.NET