

NO.	DESCRIPTION	Q'TY	SPECIFICATION
1	WIPER	1	38.1±0.63 4.75/7.14
2	O-RING	1	
3	BACK-UP RING	1	
4	D-CUP SEAL	1	38.1±0.63±7.92
5	GLAND	1	
6	WBAR RING	1	
7	BACK-UP RING	1	
8	O-RING	1	3.53±0.6.74
9	PISTON ROD	1	
10	CYLINDER	1	
11	PISTON	1	
12	BACK-UP RING	2	
13	SEALS	1	38.5±0.83±7.19
14	BACK-UP RING	2	
15	O-RING	1	2.4±0.8
16	NYLOCK NUT	1	M20*1.5
17	END CUP	1	
18	BACK/ROD CLEVIS	2	
19	STBEL PIPE PLUG	2	
20	SOCKETS	2	3/4"-16UNF
21	O-RING	2	

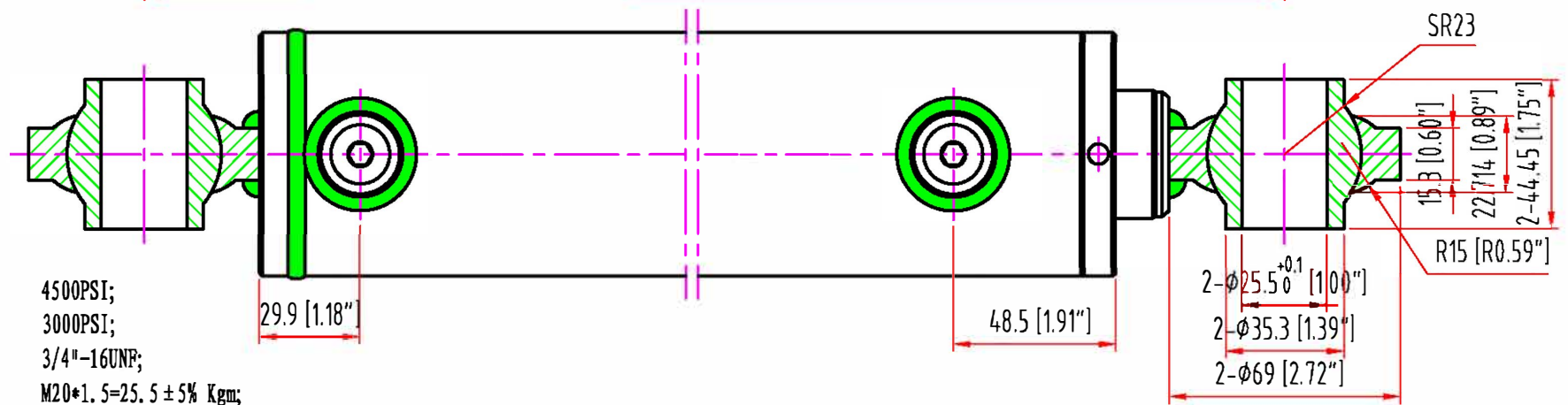
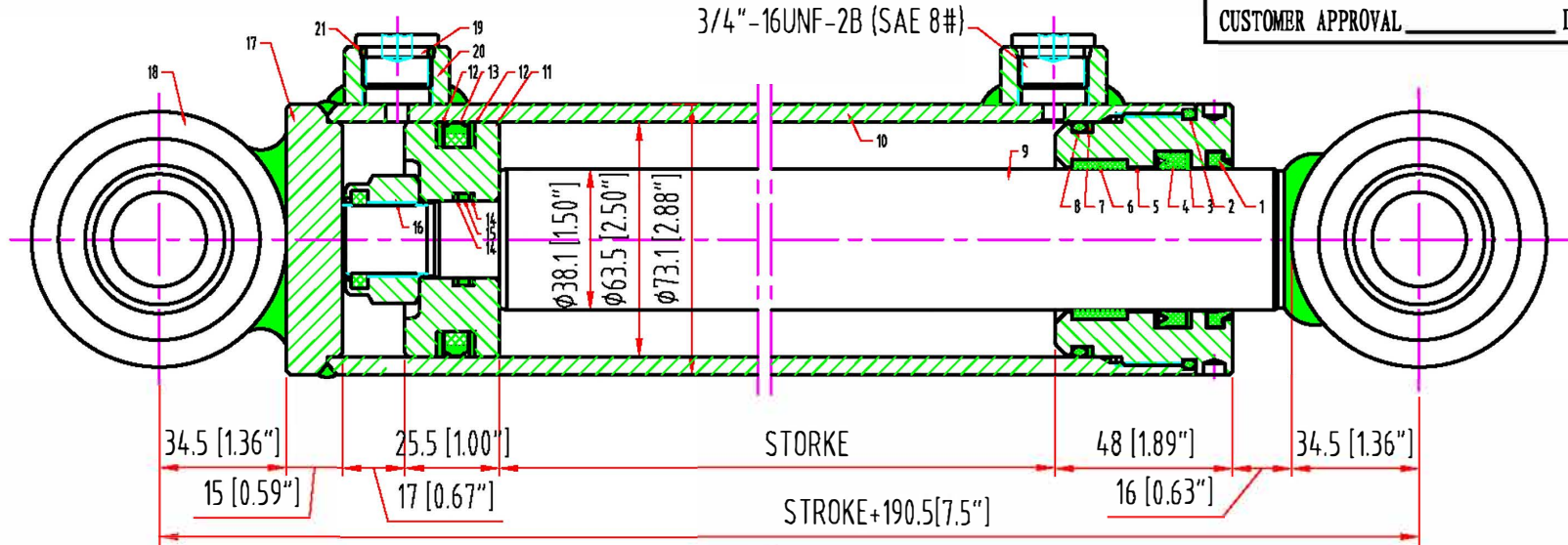

**PRODUCT NOTES:**  
 1. TEST PRESSURE: 4500PSI;  
 2. WORKING PRESSURE: 3000PSI;  
 3. PORT PLUG: 3/4"-16UNF;  
 4. TORQUE ON PISTON: M20\*1.5=25.5 ± 5% Kgm;  
 5. PAINT COLOR: BLACK;

NO.	ITEM	STROKE	R. LGHT	SBPG.	DWG#
1	400-519	6"	13.5"		BA25152G-0000-000000
2	400-520	8"	15.5"		BA25203G-0000-000000
3	400-521	10"	17.5"		BA25254G-0000-000000
4	400-522	12"	19.5"		BA25305G-0000-000000
5	400-523	20"	27.5"		BA25508G-0000-000000
6	400-524	24"	31.5"		BA25610G-0000-000000
7	400-525	30"	37.5"		BA25762G-0000-000000

REV. SYMBOL		REV	DATE	DWG#	ITEM	Q'TY	SPECIFICATION	MATL
△ X				BA25000G-0000-000000	CYLINDER			
T O L E R A N C E S		RATE		DRAWER	DESIGNER	QA	APPD	DATE
DIMENSION OVER-UP TO		CLASS1	CLASS2	CLASS3	CLASS4	SCALE		
6 BELOW		0.05	0.1	0.2	0.5	MFG. SYMBOL		
6 - 30		0.10	0.2	0.5	1			
30 - 100		0.15	0.3	0.8	15			
100 - 300		0.20	0.5	1.2	2			
300 - 1000		0.30	0.8	2	3			
						REF.DWG#		

CUSTOMER APPROVAL \_\_\_\_\_ DATE \_\_\_\_\_