

NO.	DESCRIPTION	Q'TY	SPECIFICATION
1	WIPER	1	25.4*34.93* 4.75/7.14
2	BACK-UP RING	1	
3	U-CUP SEAL	1	25.4*34.93*6.35
4	BACK-UP RING	1	
5	O-RING	1	2.62*37.77
6	GLAND	1	
7	PISTON ROD	1	
8	CYLINDER	1	
9	PISTON	1	
10	SEALS	2	Ø8*30.5*3.2 KPT
11	BACK-UP RING	2	
12	O-RING	1	2.4*19.8
13	NYLOCK NUT	1	M18*1.5
14	END CUP	1	
15	BACK/ROD CLEVIS	2	
16	STEEL PIPE PLUG	4	
17	SOCKES	4	9/16"-18UNF
18	O-RING	4	

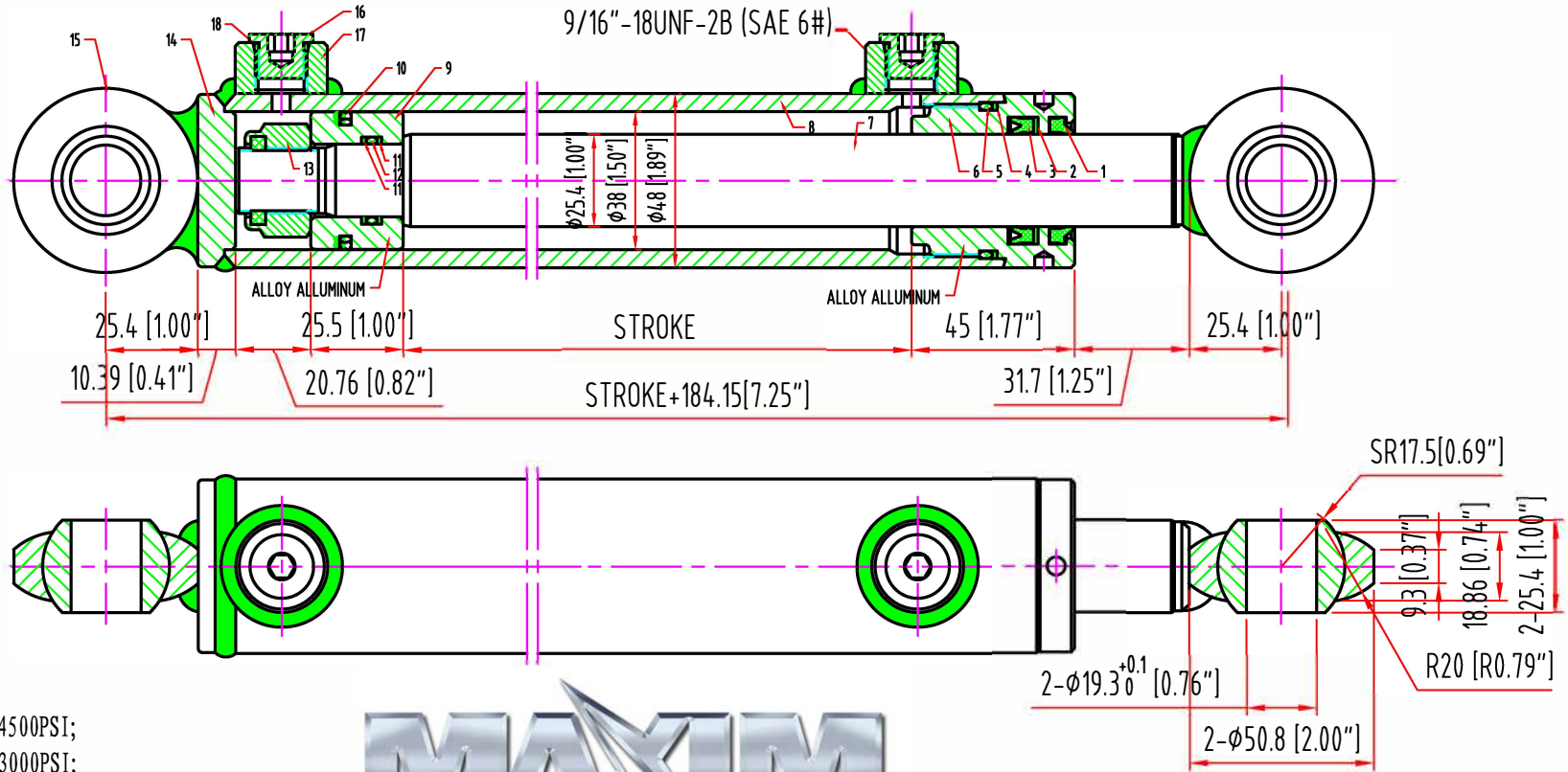

**PRODUCT NOTES:**

1. TEST PRESSURE: 4500PSI;
2. WORKING PRESSURE: 3000PSI;
3. TORQUE ON PORT PLUG: 9/16"-18UNF=0.7-1.4KgM;
4. TORQUE ON PISTON: M18\*1.5=18 ± 5% KgM;
5. PAINT COLOR: BLACK;



NO.	ITEM	STROKE	R. LGHT	SHPG.	
1	400-505	4"	11.25"		BA15102G-0000-000000
2	400-506	6"	13.25"		BA15152G-0000-000000
3	400-507	8"	15.25"		BA15203G-0000-000000
4	400-508	10"	17.25"		BA15254G-0000-000000
5	400-509	12"	19.25"		BA15305G-0000-000000
6	400-510	14"	21.25"		BA15356G-0000-000000

REV. SYMBOL	REV	DATE	DWG#	ITEM	Q'TY	SPECIFICATION	MATL
				CYLINDER			
TOLERANCE			DRAWER		DESIGNER	QA	APPD
DIMENSION OVER-UP TO			DATE		SCALE		
6 BELOW					MFG. SYMBOL		
6 - 30							
30 - 100							
100 - 300							
300 - 1000							