

Section A-A

NAME: HYDRAULIC POWER UNIT
 PART NUMBER:
 DESIGN:
 REV: DATE:
 CUSTOMERS PART#: 253-102

9	Remote Control	2 Botton, 3 Lines, 10 feet
8	Manifold	
7	Relief Valve	Relief Pressure 2500 PSI
6	DC Motor	2.0 HP, 12V, 2600RPM, S3 duty
5	Solenoid Release Valve	12VDC, NC
4	Check Valve	
3	pump	CBK-F2.1F, 0.128 Cu.In/Rev
2	Suction filter	
1	Tank	Steel, 2.5 Gallons, Horizontal
NO.	Description	Technica data

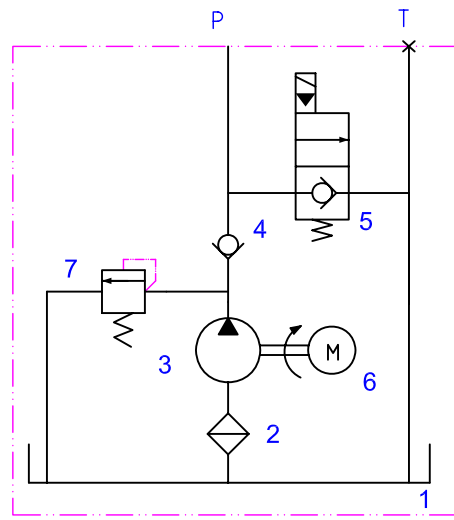

Hydraulic Schematic

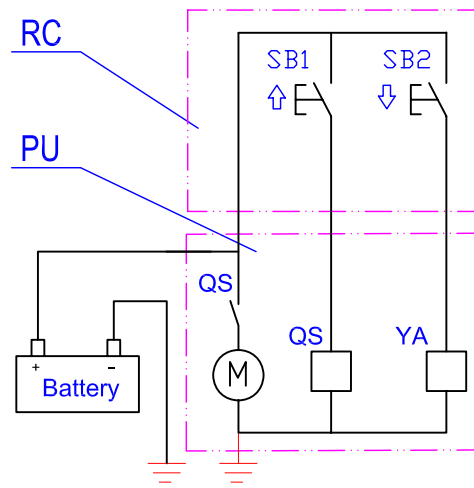

Electric Schematic