

FMA ROTARY GEAR FLOW DIVIDERS

General Description

FMA flow dividers provide efficient, reliable service for a wide variety of applications in agricultural, materials handling as well as in construction equipment, they have the following functions from a single pump source:

- synchronized operation of multiple cylinders or hydraulic motors.
- proportional division of pump output among several circuits.
- intensified pressure when pressure higher than pump capacity is needed.



Order Code

FMA - * * * * *

2	2个 2 Section	Number Of Section
4	4个 4 Section	
6	6个 6 Section	

R	With Relief Valve	Relief Valve
N	Without Relief Valve	

Detailed description

Ports Configurations	S	SAE SAE O-ring boss
	N	NPT NPT Ports (BSPP)
	G	BSPP Ports

Displacement Of Each Section	0.061-0.5370 in ³ /r 1.0-8.8 cc/r
------------------------------	---

Outline Dimension

FMA*-2R**

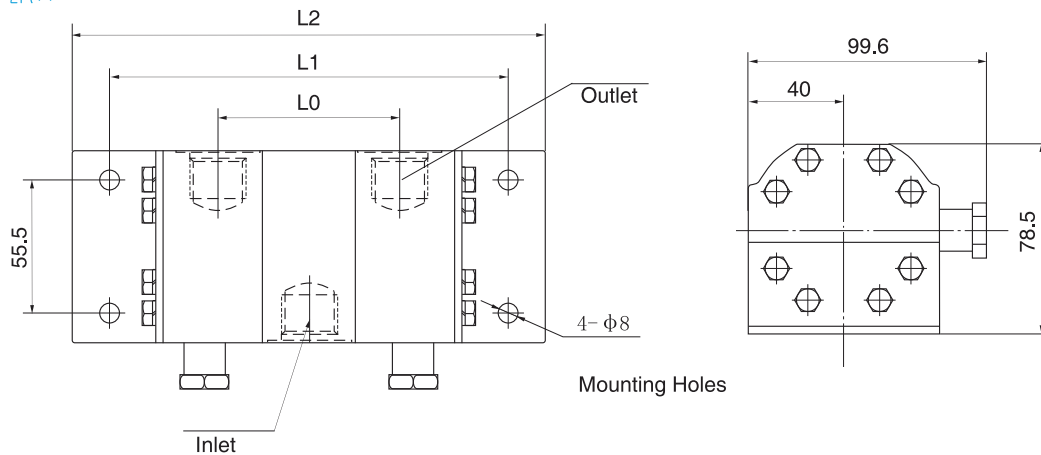

Hydraulic Schematic

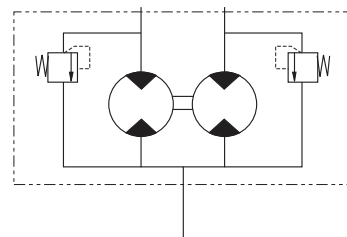

FMA*-4R**

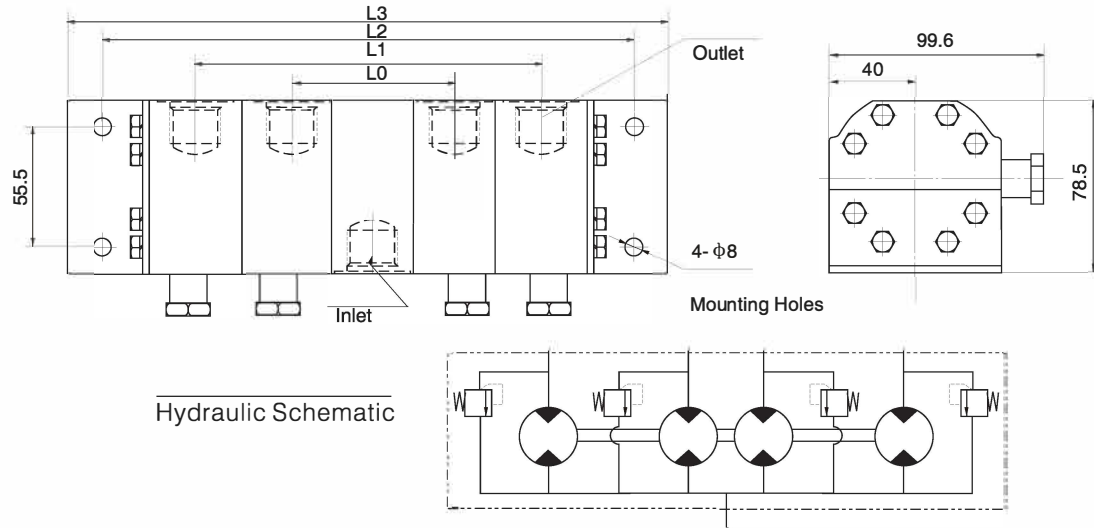

FMA*-6R**

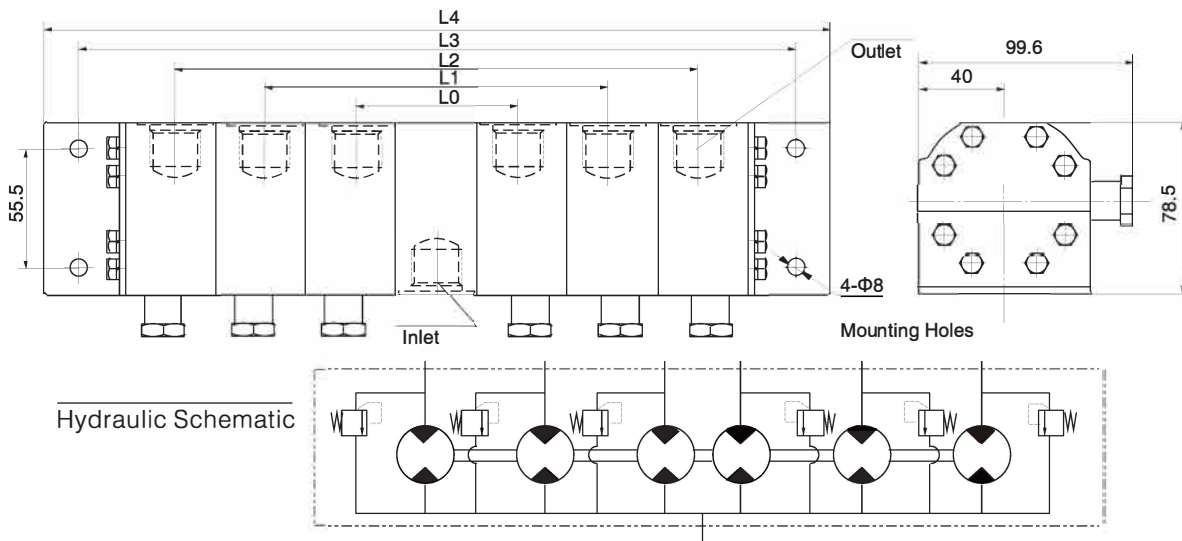

Technical Data

Model	Displacement	Minimum inlet flow	Standard inlet flow	Maximum inlet flow	Maximum outlet pressure	Ports		Dimension(mm)				
	mL/r	L/Min	L/Min	L/Min		MPa	Inlet	Outlet	L0	L1	L2	L3
FMA-2*1.8*	1.88	2.82	5.64	11.28	25	3/4-16UNF G1/2 NPT1/2	3/4-16UNF G1/2 NPT1/2	74.4	152.2	186.8		
FMA-2*2.1*	2.17	3.26	6.51	13.02				72.5	151.4	183		
FMA-2*3*	3.18	4.77	9.54	19.08				76	158.4	190		
FMA-2*4.2*	4.34	6.51	13.02	26.04		7/8-14UNF G5/8 NPT1/2	7/8-14UNF G5/8 NPT1/2	76	166	198		
FMA-2*5*	4.89	7.34	14.67	29.34				79.8	170.2	201.8		
FMA-2*6.3*	6.37	9.56	19.11	38.22				90	180	212		
FMA-2*8.8*	8.82	13.23	26.46	52.92		107	197.4	229				
FMA-4*2.1*	2.17	6.51	13.02	26.04	21	3/4-16UNF G1/2 NPT1/2	3/4-16UNF G1/2 NPT1/2	72.5	159.5	238.8	270	
FMA-4*3*	3.18	9.54	19.08	38.16				76	170	252.4	284	
FMA-4*4.2*	4.34	13.02	26.04	52.08		7/8-14UNF G5/8 NPT1/2	7/8-14UNF G5/8 NPT1/2	76	178	268.4	300	
FMA-4*5*	4.89	14.67	29.34	58.68				79.8	185.6	276	307.6	
FMA-4*6.3*	6.37	19.11	38.22	76.44				90	206	296.4	328	
FMA-4*8.8*	8.82	26.46	52.92	105.84		107	240	330.4	362			
FMA-6*2.1*	2.17	9.78	19.53	39.06		16	7/8-14UNF G5/8 NPT1/2	3/4-16UNF G1/2 NPT1/2	72.5	159.9	247.3	326