

Features

DFC-51 model is a full range pressure compensating variable flow control. It is designed so that the orifice area varies as the lever is rotated. The outlet flow is smooth and constant regardless of the pressure on the the control flow or excess flow ports. An adjustable ball spring relief allows for pressure compensated flow up to the pressure setting on the relief. Relief valves are preset at 1500 psi and field adjustable from 750 to 3000 PSI.

Materials

Cast Iron Body, Heat Treated Compensator Spool, Stainless Steel Rotary Spool, Buna N "O" rings (standard)

Installation Data

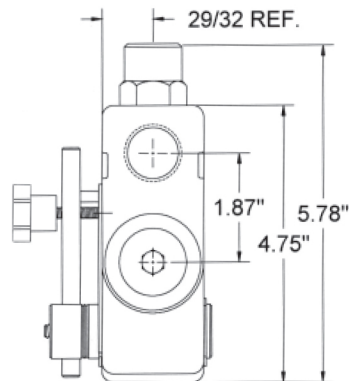
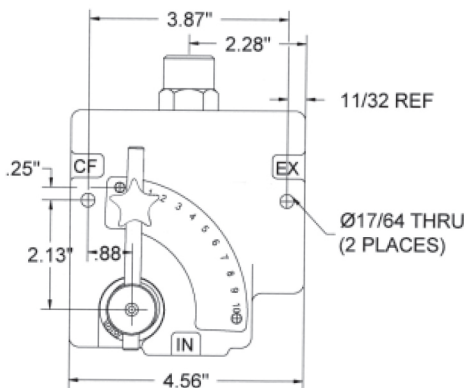

Port Code	Size	Flow	Port Code	Size	Flow
38 - N	3/8" - NPT	0-8 gpm	06 - S	9/16 - 18 SAE	0-8 gpm
12 - N	1/2" - NPT	0-16 gpm	10 - S	7/8 - 14 SAE	0-16 gpm
34 - N	3/4" - NPT	0-30 gpm	12 - S	1-1/16 - 12 SAE	0-30 gpm

Ordering Information

DFC - **R** - **51** - **34** - **N**

Pressure compensated flow control

R - Adjustable ball spring relief.

*N - No relief.

Standard flow control

Port Size:

12
34
12

*06

*38

*10

N - NPT
S - SAE

* special order minimum order quantity required, consult factory.