

MODEL BMRS

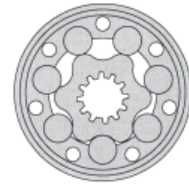

NOW with Radial Bearings for side load applications

The BMRS series advanced **ROLORTORC™** gear set, shaft distribution flow, hydraulic motor is a compact, low noise, high efficient high torque low speed design. The **ROLORTORC™** gear set also affords a reliable smooth start up at low pressure.

The low weight advanced construction design is manufactured in accordance with the requirements of ISO 9000-2000 quality system.

Technical Specifications - BMRS

MODEL		BMRS50	BMRS80	BMRS100	BMRS125	BMRS160	BMRS200	BMRS250	BMRS315	BMRS375
Displacement Cm ³ /Rev (In ³ /Rev)		51.3 (3.05)	80.6 (4.92)	101 (6.15)	125 (7.63)	157 (9.6)	199 (12.16)	252 (15.38)	315 (19.2)	370 (22.6)
	Maximum Speed RPM	Cont 755 Int. 970	750 940	600 750	475 600	375 470	300 375	240 300	190 240	160 200
Max Torque NM / (in.lbs)	Cont	100 (885)	190 (1682)	240 (2124)	292 (2584)	363 (3273)	358 (3168)	352 (3115)	360 (3186)	420 (3717)
	Int.	126 (1115)	220 (1947)	280 (2478)	340 (3010)	430 (3806)	448 (3965)	470 (4159)	480 (4247)	548 (4850)
Max Differential Mpa / (PSI)	Cont	14 (2061)	17.5 (2576)	17.5 (2576)	17.5 (2576)	16.5 (2429)	13 (1914)	11 (1625)	8.5 (1251)	8.5 (1251)
	Int.	17.5 (2576)	20 (2944)	20 (2944)	20 (2944)	20 (2944)	17.5 (2576)	14 (2061)	11.5 (1693)	11.5 (1693)
Max Flow L/min / (gpm)	Cont	40 (10.5)	60 (15.8)	60 (15.8)	60 (15.8)	60 (15.8)	60 (15.8)	60 (15.8)	60 (15.8)	60 (15.8)
	Int.	50 (13.15)	75 (19.75)	75 (19.75)	75 (19.75)	75 (19.75)	75 (19.75)	75 (19.75)	75 (19.75)	75 (19.75)
Weight Kg / (lbs)		6.7 (14.8)	6.9 (15.2)	6.9 (15.2)	7.2 (15.8)	7.5 (16.5)	8.0 (17.6)	8.5 (18.7)	9.0 (19.8)	9.3 (20.5)

Continuous = maximum of continuous operation

Intermittent = maximum operating range for 6 seconds per minute

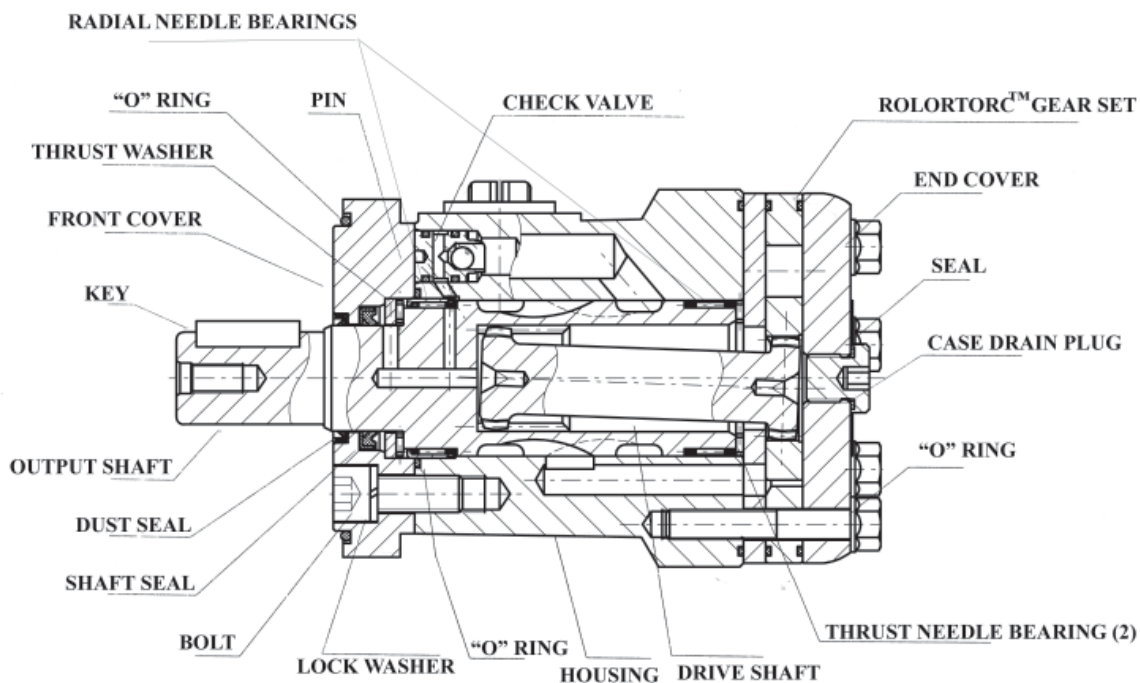

BMRS INSTALLATION DATA

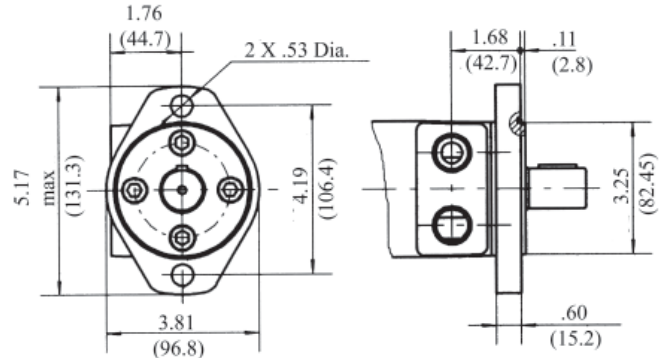
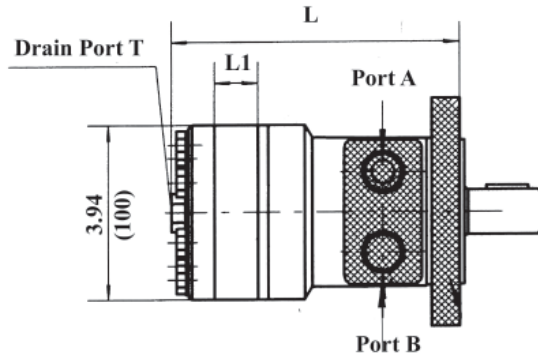

H2 - SAE -"A" 2 BOLT

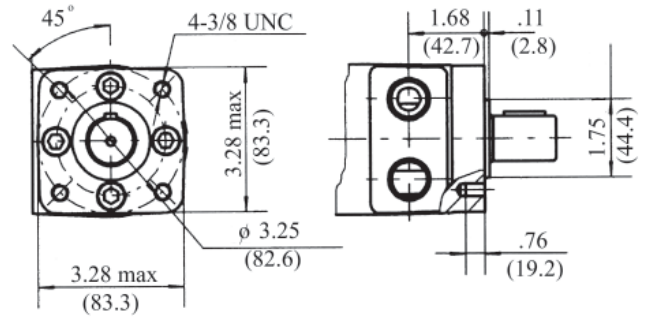
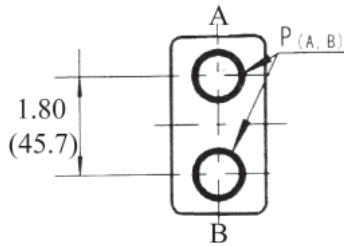

H4 - SAE -"A" 4 BOLT

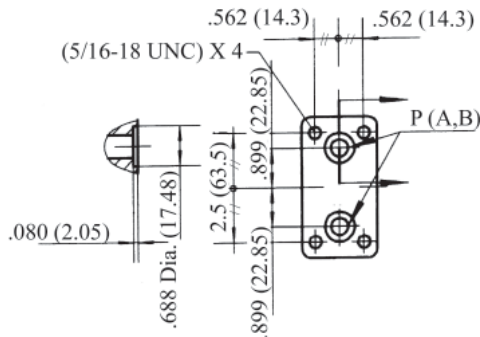

Manifold Mount

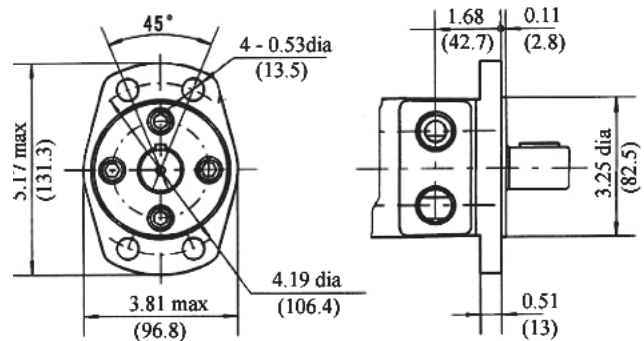

H6 - Magneto

MODEL BMRS	L		L1	
	inches	mm	inches	mm
BMRS 50	5.67	144	.39	10
BMRS 80	5.90	150	.63	16
BMRS 100	6.06	154	.79	20
BMRS 125	6.26	159	.98	25
BMRS 160	6.51	165.5	1.24	31.5
BMRS 200	6.85	174	1.57	40
BMRS 250	7.24	184	1.97	50
BMRS 315	7.72	196	2.44	62
BMRS 375	8.19	208	2.91	74

PORT SIZES	S	P
P (A,B)	7/8-14 SAE	1/2-14 NPTF
T	7/16-20 SAE	7/16-20 SAE

MODEL BMRS DRIVE SHAFT DATA

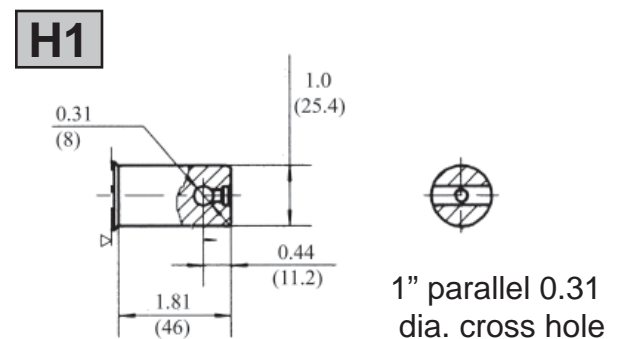
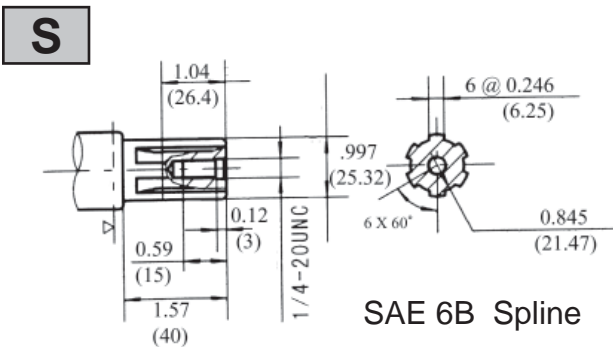
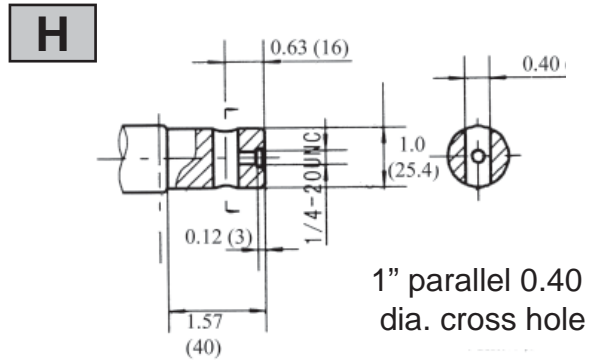
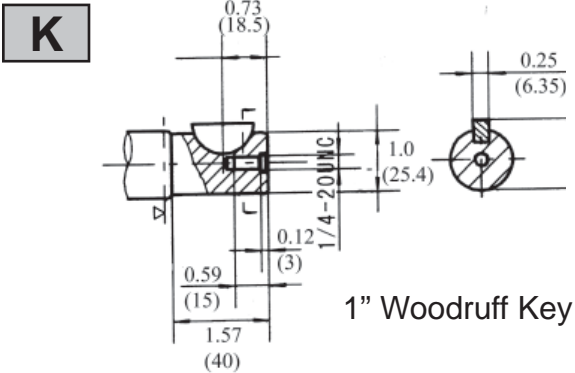

BMRS MODEL NUMBER DATA

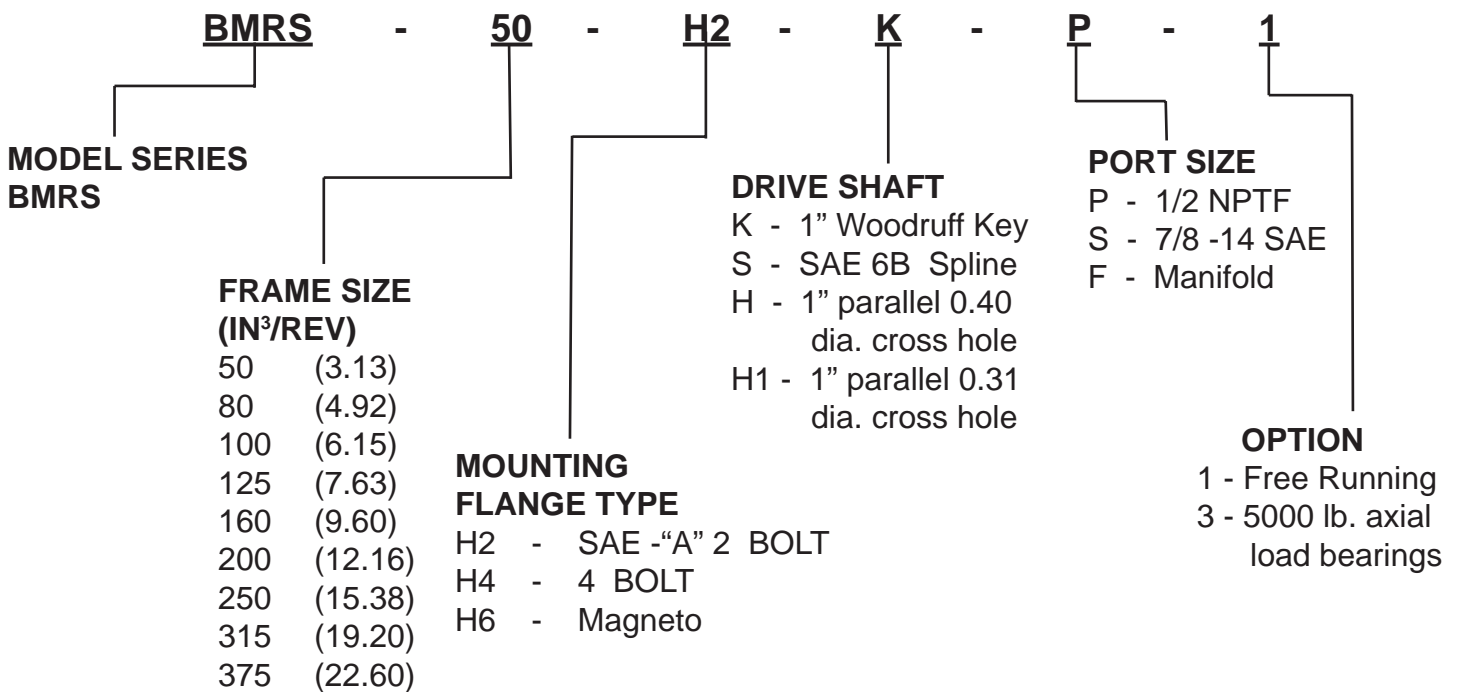

Additional flange and drive shaft options available please consult factory

BMRS 50		51.3 Cm ³ /Rev 3.13 in ³ /Rev					Max Cont.	Max Int.		
Pressure Mpa (psi)		5 (376)	7 (1030)	9 (1352)	10 (1470)	12 (1766)	14 (2060)	16 (2355)	17.5 (2576)	
F L O W	LPM (GPM)	Torque Mn (in.Lbs) Speed Specification								
	5 (1.32)	35 (310)	45 (398)	61 (540)	67 (593)	77 (681)	88 (779)			
		95 rpm	84 rpm	76 rpm	73 rpm	69 rpm	46 rpm			
	10 (2.65)	36 (316)	46 (407)	62 (549)	69 (611)	80 (708)	95 (841)	108 (956)	120 (1062)	
		184 rpm	176 rpm	165 rpm	162 rpm	150 rpm	130 rpm	111 rpm	84 rpm	
	15 (3.95)	35 (310)	49 (434)	63 (558)	73 (646)	88 (779)	100 (885)	109 (965)	123 (1089)	
		283 rpm	277 rpm	269 rpm	261 rpm	250 rpm	230 rpm	211 rpm	185 rpm	
	20 (5.26)	34 (301)	47 (416)	61 (540)	69 (611)	83 (735)	96 (850)	109 (965)	126 (1115)	
		377 rpm	375 rpm	365 rpm	361 rpm	346 rpm	330 rpm	308 rpm	276 rpm	
	25 (6.60)	34 (301)	45 (398)	61 (540)	69 (611)	81 (717)	96 (850)	109 (965)	126 (1115)	
		476 rpm	468 rpm	460 rpm	453 rpm	438 rpm	423 rpm	395 rpm	361 rpm	
	30 (7.90)	33 (292)	44 (389)	60 (531)	67 (593)	80 (708)	95 (841)	108 (956)	126 (1115)	
	576 rpm	569 rpm	561 rpm	554 rpm	542 rpm	531 rpm	500 rpm	465 rpm		
	35 (9.20)	31 (274)	42 (372)	59 (522)	66 (584)	80 (708)	93 (823)	107 (947)	124 (1097)	
		669 rpm	665 rpm	657 rpm	654 rpm	638 rpm	623 rpm	598 rpm	561 rpm	
Max Cont.	40 (10.50)	30 (266)	41 (363)	58 (513)	66 (584)	79 (699)	92 (814)	106 (938)	122 (1080)	
		760 rpm	758 rpm	753 rpm	750 rpm	738 rpm	727 rpm	700 rpm	670 rpm	
Max Int.	45 (11.85)	29.5 (281)	40 (354)	57 (504)	65 (575)	78 (690)	90 (797)	105 (929)	121 (1071)	
		856 rpm	856 rpm	850 rpm	845 rpm	835 rpm	815 rpm	799 rpm	780 rpm	

BMRS 80		80.6 Cm ³ /Rev 4.9 in ³ /Rev					Max Cont.	Max Int.		
Pressure Mpa (psi)		5 (376)	7 (1030)	9 (1352)	10 (1470)	12 (1766)	14 (2060)	16 (2355)	17.5 (2576)	
F L O W	LPM (GPM)	Torque Mn (in.Lbs) Speed Specification								
	10 (2.65)	55 (487)	77 (681)	98 (867)	107 (947)	130 (1151)	149 (1319)	170 (1505)	180 (1593)	
		115 rpm	109 rpm	106 rpm	101 rpm	91 rpm	75 rpm	53 rpm	45 rpm	
	20 (5.25)	50 (443)	81.6 (722)	105 (938)	118 (1044)	132 (1168)	160 (1416)	178 (1575)	189 (1673)	
		239 rpm	235 rpm	227 rpm	224 rpm	209 rpm	196 rpm	172 rpm	160 rpm	
	30 (7.90)	48 (425)	74 (655)	97 (858)	114 (1009)	131 (1159)	150 (1328)	179 (1584)	190 (1682)	
		364 rpm	360 rpm	357 rpm	345 rpm	332 rpm	321 rpm	300 rpm	284 rpm	
	40 (10.50)	45 (398)	71 (628)	95 (841)	105 (929)	128 (1133)	149 (1319)	177 (1566)	188 (1664)	
		488 rpm	483 rpm	475 rpm	472 rpm	460 rpm	447 rpm	420 rpm	408 rpm	
	50 (13.15)	42 (372)	70 (620)	90 (797)	98 (867)	125 (1106)	147 (1301)	171 (1513)	187 (1655)	
		619 rpm	615 rpm	607 rpm	598 rpm	593 rpm	568 rpm	547 rpm	535 rpm	
	60 (15.80)	38 (336)	63 (558)	85 (752)	95 (841)	118 (1044)	142 (1257)	169 (1496)	185 (1637)	
	740 rpm	725 rpm	721 rpm	715 rpm	707 rpm	688 rpm	667 rpm	657 rpm		
Max Cont.	70 (18.40)	36 (319)	58 (513)	80 (708)	89 (788)	112 (991)	139 (1230)	164 (1451)	179 (1584)	
		860 rpm	853 rpm	839 rpm	837 rpm	823 rpm	811 rpm	790 rpm	776 rpm	
Max Int.	75 (19.75)	29 (257)	56 (496)	77 (681)	85 (752)	110 (974)	133 (1177)	161 (1425)	177 (1566)	
		925 rpm	915 rpm	910 rpm	899 rpm	888 rpm	871 rpm	853 rpm	837 rpm	

BMRS 100		100.8 Cm ³ /Rev 6.15 in ³ /Rev					Max Cont.	Max Int.		
Pressure Mpa (psi)		5 (376)	7 (1030)	9 (1352)	10 (1470)	12 (1766)	14 (2060)	16 (2355)	17.5 (2576)	
F L O W	LPM (GPM)	Torque Mn (in.Lbs) Speed Specification								
	10 (2.65)	70 (620)	100 (885)	122 (1080)	138 (1221)	159 (1407)	182 (1611)	210 (1859)	222 (1965)	
		99 rpm	95 rpm	87 rpm	84 rpm	74 rpm	63 rpm	52 rpm	44 rpm	
	20 (5.25)	68 (602)	95 (841)	123 (1089)	143 (1266)	165 (1460)	200 (1770)	221 (1956)	238 (2106)	
		199 rpm	194 rpm	188 rpm	182 rpm	175 rpm	162 rpm	150 rpm	138 rpm	
	30 (7.90)	62 (547)	94 (832)	121 (1071)	140 (1239)	164 (1451)	194 (1717)	220 (1947)	240 (2124)	
		299 rpm	294 rpm	288 rpm	284 rpm	278 rpm	263 rpm	249 rpm	236 rpm	
	40 (10.50)	59 (522)	88 (779)	119 (1053)	134 (1186)	161 (1425)	192 (1699)	218 (1929)	238 (2106)	
		400 rpm	398 rpm	387 rpm	385 rpm	380 rpm	366 rpm	350 rpm	336 rpm	
	50 (13.15)	55 (487)	83 (735)	117 (1035)	125 (1106)	157 (1389)	185 (1637)	217 (1920)	235 (2080)	
		498 rpm	496 rpm	488 rpm	484 rpm	475 rpm	464 rpm	450 rpm	436 rpm	
	60 (15.80)	48 (425)	79 (699)	110 (974)	119 (1053)	152 (1345)	180 (1593)	214 (1894)	233 (2062)	
	599 rpm	595 rpm	587 rpm	585 rpm	579 rpm	569 rpm	552 rpm	538 rpm		
Max Cont.	70 (18.40)	43 (381)	70 (620)	100 (885)	112 (991)	142 (1257)	170 (1505)	201 (1789)	229 (2027)	
		699 rpm	693 rpm	687 rpm	683 rpm	679 rpm	668 rpm	648 rpm	636 rpm	
Max Int.	75 (19.75)	39 (345)	63 (558)	97 (858)	105 (929)	140 (1239)	167 (1478)	197 (1743)	227 (2009)	
		748 rpm	741 rpm	737 rpm	735 rpm	720 rpm	713 rpm	697 rpm	686 rpm	

BMRS 125		124.9 Cm³/Rev 7.63 in³/Rev					Max Cont.	Max Int.	
Pressure Mpa (psi)		5 (376)	7 (1030)	9 (1352)	10 (1470)	12 (1766)	14 (2060)	16 (2355)	17.5 (2576)
F L O W	LPM (GPM)	Torque Mn (in.Lbs) Speed Specification							
	10 (2.65)	90 (797)	122 (1080)	160 (1416)	173 (1531)	205 (1814)	237 (2097)	258 (2283)	270 (2390)
		73 rpm	71 rpm	66 rpm	63 rpm	55 rpm	42 rpm	23 rpm	14 rpm
	20 (5.25)	85 (752)	118 (1044)	159 (1407)	172 (1522)	208 (1841)	250 (2213)	278 (2460)	292 (2584)
		154 rpm	152 rpm	150 rpm	145 rpm	138 rpm	123 rpm	109 rpm	91 rpm
	30 (7.90)	82 (726)	107 (947)	158 (1398)	164 (1451)	206 (1823)	241 (2133)	277 (2451)	291 (2575)
		237 rpm	236 rpm	233 rpm	226 rpm	219 rpm	207 rpm	192 rpm	170 rpm
	40 (10.50)	79 (699)	105 (929)	150 (1320)	161 (1425)	204 (1895)	238 (2106)	275 (2434)	289 (2558)
		315 rpm	313 rpm	309 rpm	307 rpm	302 rpm	297 rpm	272 rpm	254 rpm
	50 (13.15)	75 (664)	96 (850)	145 (1283)	160 (1416)	198 (1752)	236 (2089)	262 (2319)	282 (2496)
	398 rpm	397 rpm	395 rpm	391 rpm	381 rpm	368 rpm	353 rpm	337 rpm	
	60 (15.80)	62 (549)	95 (841)	139 (1230)	158 (1938)	183 (1389)	222 (1965)	254 (2248)	279 (2469)
		475 rpm	473 rpm	471 rpm	470 rpm	463 rpm	450 rpm	427 rpm	416 rpm
Max Cont.	70 (18.40)	59 (522)	83 (735)	125 (1106)	150 (1328)	178 (1575)	212 (1876)	250 (2213)	262 (2319)
		554 rpm	553 rpm	551 rpm	550 rpm	546 rpm	538 rpm	514 rpm	500 rpm
Max Int.	75 (19.75)	56 (496)	80 (708)	122 (1080)	145 (1283)	172 (1522)	205 (1814)	245 (2168)	261 (2310)
		598 rpm	597 rpm	593 rpm	590 rpm	586 rpm	577 rpm	551 rpm	537 rpm

BMRS 160		157.2 Cm³/Rev 9.60 in³/Rev					Max Cont.	Max Int.	
Pressure Mpa (psi)		5 (376)	7 (1030)	9 (1352)	10 (1470)	12 (1766)	14 (2060)	16 (2355)	17.5 (2576)
F L O W	LPM (GPM)	Torque Mn (in.Lbs) Speed Specification							
	10 (2.65)	115 (1018)	160 (14160)	203 (1797)	220 (1947)	260 (2301)	300 (2655)	340 (3009)	363 (3204)
		58 rpm	55 rpm	52 rpm	50 rpm	44 rpm	38 rpm	34 rpm	26 rpm
	20 (5.25)	114 (1009)	160 (1416)	205 (1814)	230 (2036)	265 (2345)	320 (2832)	355 (3142)	380 (3363)
		119 rpm	115 rpm	111 rpm	108 rpm	103 rpm	95 rpm	84 rpm	76 rpm
	30 (7.90)	105 (929)	158 (1398)	202 (1788)	221 (1956)	261 (2310)	305 (2699)	344 (3044)	378 (3345)
		184 rpm	181 rpm	177 rpm	172 rpm	165 rpm	153 rpm	134 rpm	130 rpm
	40 (10.50)	100 (885)	145 (1283)	196 (1735)	218 (1929)	257 (2274)	299 (2646)	340 (3009)	374 (3310)
		246 rpm	244 rpm	239 rpm	237 rpm	230 rpm	218 rpm	199 rpm	184 rpm
	50 (13.15)	90 (797)	140 (1239)	190 (1682)	209 (1850)	250 (2213)	295 (2611)	336 (2974)	366 (3239)
	307 rpm	305 rpm	302 rpm	300 rpm	292 rpm	280 rpm	262 rpm	244 rpm	
	60 (15.80)	84 (743)	136 (1204)	180 (1593)	199 (1761)	240 (2124)	286 (2531)	330 (2921)	360 (3186)
		370 rpm	368 rpm	364 rpm	362 rpm	355 rpm	342 rpm	334 rpm	304 rpm
Max Cont.	70 (18.40)	65 (575)	120 (1062)	164 (1451)	180 (1593)	223 (1974)	280 (2478)	320 (2832)	350 (3098)
		435 rpm	434 rpm	430 rpm	427 rpm	416 rpm	405 rpm	335 rpm	366 rpm
Max Int.	75 (19.75)	59 (522)	116 (1026)	158 (1398)	175 (1549)	220 (1947)	272 (2407)	314 (2779)	342 (3027)
		465 rpm	462 rpm	458 rpm	456 rpm	447 rpm	433 rpm	416 rpm	395 rpm

BMRS 200		199.2 Cm³/Rev 12.16 in³/Rev				Max Cont.	Max Int.	
Pressure Mpa (psi)		5 (376)	7 (1030)	9 (1352)	10.5 (1546)	12 (1766)	14 (2060)	17.5 (2576)
F L O W	LPM (GPM)	Torque Mn (in.Lbs) Speed Specification						
	10 (2.65)	148 (1310)	205 (1814)	255 (2257)	290 (2567)	327 (2894)	370 (3275)	442 (3912)
		49 rpm	47 rpm	45 rpm	43 rpm	40 rpm	30 rpm	24 rpm
	20 (5.25)	140 (1239)	202 (1788)	250 (2213)	323 (2859)	330 (2921)	411 (3637)	448 (3965)
		99 rpm	97 rpm	93 rpm	90 rpm	86 rpm	78 rpm	65 rpm
	30 (7.90)	130 (1151)	193 (1708)	241 (2133)	307 (2717)	325 (2876)	377 (3336)	445 (3938)
		149 rpm	146 rpm	140 rpm	136 rpm	131 rpm	122 rpm	105 rpm
	40 (10.50)	125 (1106)	186 (1646)	232 (2953)	305 (2699)	313 (2770)	390 (3452)	436 (3860)
		200 rpm	197 rpm	192 rpm	188 rpm	181 rpm	170 rpm	149 rpm
	50 (13.15)	120 (1062)	177 (1566)	225 (1991)	295 (2611)	305 (2699)	382 (3381)	427 (3779)
	250 rpm	247 rpm	242 rpm	238 rpm	231 rpm	218 rpm	193 rpm	
	60 (15.80)	110 (974)	166 (1469)	221 (1956)	285 (25220)	292 (2584)	372 (3292)	419 (3708)
		300 rpm	298 rpm	291 rpm	287 rpm	282 rpm	268 rpm	236 rpm
Max Cont.	70 (18.40)	98 (867)	150 (1328)	205 (1814)	244 (2159)	278 (2461)	331 (2929)	410 (3629)
		350 rpm	347 rpm	342 rpm	338 rpm	331 rpm	318 rpm	282 rpm
Max Int.	75 (19.75)	85 (752)	141 (1248)	199 (1761)	235 (2080)	268 (2372)	323 (2859)	400 (3540)
		375 rpm	372 rpm	366 rpm	362 rpm	357 rpm	343 rpm	310 rpm

BMRS 250		252 Cm³/Rev 15.38 in³/Rev					Max Cont.	Max Int.		
Pressure Mpa (psi)		3 (442)	5 (376)	7 (1030)	9 (1352)	10.5 (1546)	12 (1766)	14 (2060)	17.5 (2576)	
F L O W	LPM (GPM)	Torque Mn (in.Lbs) Speed Specification								
	10 (2.65)	115 (1018) 40 rpm	180 (1593) 38 rpm	251 (2221) 37 rpm	295 (2611) 35 rpm	350 (3098) 32 rpm	380 (3363) 30 rpm	470 (4160) 22 rpm	535 (4735) 16 rpm	
	20 (5.25)	110 (974) 79 rpm	178 (1575) 78 rpm	252 (2230) 75 rpm	294 (2602) 74 rpm	352 (3115) 70 rpm	385 (3407) 68 rpm	470 (4160) 57 rpm	548 (4850) 48 rpm	
	30 (7.90)	100 (885) 120 rpm	170 (1505) 119 rpm	248 (2195) 117 rpm	285 (2522) 116 rpm	348 (3080) 110 rpm	381 (3372) 107 rpm	469 (4151) 95 rpm	545 (4823) 79 rpm	
	40 (10.50)	91 (805) 158 rpm	159 (1407) 157 rpm	232 (2053) 156 rpm	268 (2372) 154 rpm	332 (2938) 151 rpm	366 (3239) 148 rpm	460 (4071) 130 rpm	530 (4691) 110 rpm	
	50 (13.15)	81 (717) 200 rpm	148 (1310) 198 rpm	216 (1912) 196 rpm	252 (2230) 195 rpm	320 (2832) 163 rpm	352 (3115) 160 rpm	453 (4009) 152 rpm	521 (4611) 147 rpm	
	60 (15.80)	75 (664) 241 rpm	132 (1168) 240 rpm	201 (1769) 239 rpm	235 (2080) 237 rpm	305 (2699) 232 rpm	340 (3009) 228 rpm	433 (3832) 210 rpm	505 (4469) 180 rpm	
	70 (18.40)	50 (443) 280 rpm	117 (1035) 279 rpm	189 (1673) 277 rpm	220 (1947) 276 rpm	290 (2567) 271 rpm	320 (2832) 268 rpm	412 (3646) 250 rpm	495 (4381) 215 rpm	
	Max Cont.	75 (19.75)	42 (372) 300 rpm	105 (929) 299 rpm	180 (1593) 298 rpm	211 (1867) 297 rpm	281 (2487) 295 rpm	310 (2744) 289 rpm	405 (3584) 272 rpm	486 (4301) 239 rpm
	Max Int.									

BMRS 315		314.5 Cm³/Rev 19.2 in³/Rev					Max Cont.	Max Int.	
Pressure Mpa (psi)		3 (442)	5 (376)	6.5 (957)	8 (1175)	9 (1325)	13 (1914)	13.5 (1987)	
F L O W	LPM (GPM)	Torque Mn (in.Lbs) Speed Specification							
	10 (2.65)	135 (1195) 31 rpm	215 (1903) 29 rpm	279 (2469) 28 rpm	343 (3036) 27 rpm	383 (3390) 27 rpm	515 (4558) 24 rpm	550 (4868) 22 rpm	
	20 (5.25)	133 (1177) 62 rpm	216 (1912) 61 rpm	289 (2558) 60 rpm	349 (3089) 58 rpm	380 (3363) 57 rpm	508 (4496) 52 rpm	552 (4886) 50 rpm	
	30 (7.90)	125 (1106) 95 rpm	205 (1814) 92 rpm	275 (2434) 91 rpm	341 (3018) 90 rpm	375 (3319) 88 rpm	494 (4372) 81 rpm	543 (4801) 79 rpm	
	40 (10.50)	113 (1000) 123 rpm	195 (1726) 121 rpm	267 (2363) 120 rpm	335 (2965) 118 rpm	367 (3248) 117 rpm	485 (4292) 106 rpm	526 (4655) 104 rpm	
	50 (13.15)	92 (814) 155 rpm	170 (1505) 154 rpm	253 (2239) 152 rpm	321 (2841) 149 rpm	352 (3115) 147 rpm	474 (4195) 137 rpm	511 (4522) 133 rpm	
	60 (15.80)	80 (708) 190 rpm	160 (1416) 187 rpm	231 (2040) 193 rpm	305 (2699) 179 rpm	334 (2956) 176 rpm	458 (4053) 163 rpm	492 (4354) 157 rpm	
	70 (18.40)	57 (504) 222 rpm	136 (1204) 220 rpm	215 (1903) 217 rpm	285 (2522) 212 rpm	320 (2832) 208 rpm	444 (3929) 192 rpm	480 (4248) 185 rpm	
	Max Cont.	75 (19.75)	55 (487) 235 rpm	124 (1097) 234 rpm	205 (1814) 231 rpm	269 (2381) 227 rpm	308 (2726) 225 rpm	427 (3779) 408 rpm	469 (4151) 201 rpm
	Max Int.								

BMRS 375		370 Cm³/Rev 22.6 in³/Rev					Max Cont.	Max Int.	
Pressure Mpa (psi)		3 (442)	5 (376)	6.5 (957)	8 (1175)	9 (1325)	13 (1914)	13.5 (1987)	
F L O W	LPM (GPM)	Torque Mn (in.Lbs) Speed Specification							
	10 (2.65)	160 (1416) 26 rpm	270 (2390) 25 rpm	340 (3009) 24 rpm	420 (3717) 22 rpm	470 (4160) 21 rpm	550 (4868) 19 rpm	610 (5399) 17 rpm	
	20 (5.25)	159 (14070) 53 rpm	260 (2301) 52 rpm	340 (3009) 51 rpm	410 (3629) 49 rpm	470 (4160) 47 rpm	540 (4779) 42 rpm	605 (5354) 37 rpm	
	30 (7.90)	150 (1328) 79 rpm	255 (2257) 78 rpm	330 (2921) 77 rpm	400 (3540) 75 rpm	450 (3983) 73 rpm	530 (4691) 67 rpm	600 (5310) 60 rpm	
	40 (10.50)	135 (1195) 106 rpm	240 (2124) 105 rpm	310 (2744) 104 rpm	375 (3319) 102 rpm	430 (3805) 99 rpm	520 (4602) 93 rpm	590 (5222) 85 rpm	
	50 (13.15)	120 (1062) 134 rpm	230 (2036) 132 rpm	295 (2511) 131 rpm	360 (3186) 129 rpm	420 (3717) 126 rpm	505 (4469) 120 rpm	570 (5045) 110 rpm	
	60 (15.80)	98 (867) 159 rpm	210 (1859) 158 rpm	275 (2434) 157 rpm	340 (3009) 155 rpm	390 (3452) 153 rpm	490 (4337) 147 rpm	550 (4868) 135 rpm	
	70 (18.40)	75 (664) 187 rpm	175 (1549) 186 rpm	250 (2213) 185 rpm	320 (2832) 183 rpm	370 (3275) 180 rpm	465 (4115) 175 rpm	530 (4691) 160 rpm	
	Max Cont.	75 (19.75)	65 (575) 200 rpm	160 (1416) 199 rpm	230 (2036) 198 rpm	310 (2744) 195 rpm	360 (3186) 192 rpm	450 (3983) 187 rpm	515 (4558) 178 rpm
	Max Int.								

MODEL BMRS TECHNICAL DATA

SHAFT SEAL RATED PRESSURE

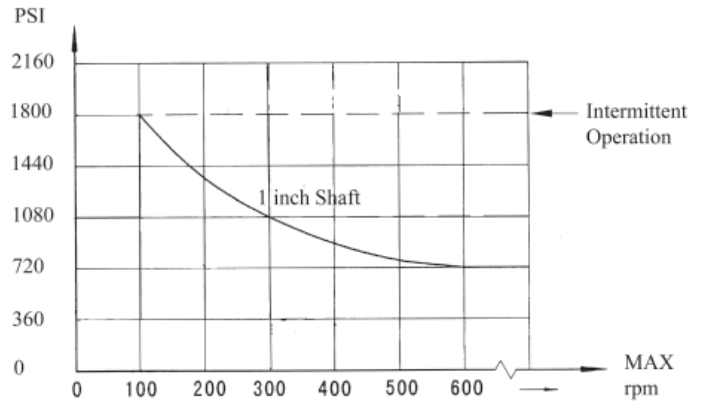
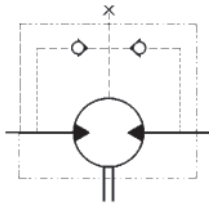

CASE DRAIN

In applications without a motor drain line, the pressure exerted on the shaft seal is marginally in excess of the return line pressure. When the drain line is used the pressure exerted on the shaft seal is equal to the return line pressure.

SHAFT ROTATION DIRECTION

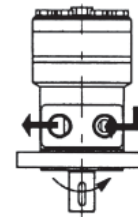

BMRS

RADIAL FORCES

Status of the shaft's radial force

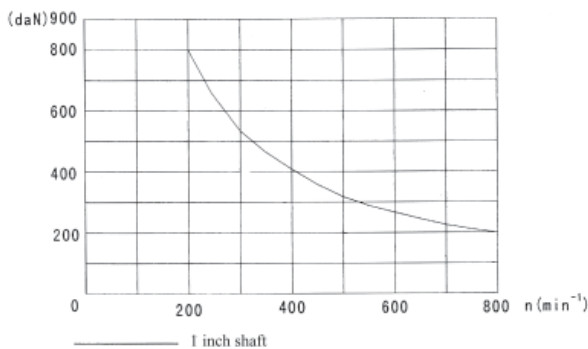

$$F_r = \frac{800 \cdot 2500}{n \cdot 95 + 1} \text{ daN}$$

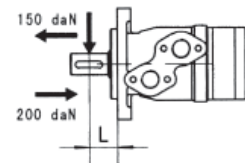

F_r =Radial Force (daN)
 L =Distance (mm)
 n =Speed (rpm)

Rhomb-flange $L=30\text{mm}$
 Square-flange $L=24\text{mm}$

BMRS CROSS REFERENCE DATA

DISPLACEMENT FOR CHIEF MOTOR Cm ³ /Rev (In ³ /Rev)													
MOUNT	SHAFT	PORTS	BRAND	51.3 (3.13)	80.6 (4.92)	100.8 (6.15)	124.9 (7.62)	157.2 (9.59)	199.2 (12.15)	252 (15.38)	314.5 (19.19)	370 (22.58)	
4 BOLT FLANGE	Woodruff Keyed	1/2" NPT	CHIEF	BMRS-50-H4-K-P	BMRS-80-H4-K-P	BMRS-100-H4-K-P	BMRS-125-H4-K-P	BMRS-160-H4-K-P	BMRS-200-H4-K-P	BMRS-250-H4-K-P	BMRS-315-H4-K-P	BMRS-375-H4-K-P	
			PRINCE	AEM50-4RP	AEM75-4RP	AEM100-4RP	N/A	AEM150-4RP	AEM200-4RP	AEM50-4RP	AEM100-4RP	AEM300-4RP	ADM400-4RP
			CHAR-LYNN®	103-1001	103-1002	103-1003	103-1755	103-1004	103-1005	103-1006	103-1007	103-1008	103-1008
			DANFOSS	151-2421	151-2422	151-2423	151-2424	151-2425	151-2426	151-2427	151-2428	151-2429	151-2429
			CHIEF	BMRS-50-H4-K-S	BMRS-80-H4-K-S	BMRS-100-H4-K-S	BMRS-125-H4-K-S	BMRS-160-H4-K-S	BMRS-200-H4-K-S	BMRS-250-H4-K-S	BMRS-315-H4-K-S	BMRS-375-H4-K-S	ADM400-4RO
			PRINCE	ADM50-4RO	AEM75-4RO	AEM100-4RO	N/A	AEM150-4RO	AEM200-4RO	AEM250-4RO	AEM300-4RO	103-1016	151-2349
	CHAR-LYNN®	103-1009	103-1010	103-1011	103-1751	103-1012	103-1013	103-1014	103-1015	103-1016	103-1016		
	DANFOSS	151-2341	151-2342	151-2343	151-2344	151-2345	151-2346	151-2347	151-2348	151-2349	151-2349		
	CHIEF	BMRS-50-H4-K-F	BMRS-80-H4-K-F	BMRS-100-H4-K-F	BMRS-125-H4-K-F	BMRS-160-H4-K-F	BMRS-200-H4-K-F	BMRS-250-H4-K-F	BMRS-315-H4-K-F	BMRS-375-H4-K-F	ADM400-4RT	103-1024	
	PRINCE	AEM50-4RT	AEM75-4RT	AEM100-4RT	N/A	AEM150-4RT	AEM200-4RT	AEM250-4RT	AEM300-4RT	103-1024	151-2509	103-1024	
	CHAR-LYNN®	103-1017	103-1018	103-1019	103-1759	103-1020	103-1021	103-1022	103-1023	103-1024	103-1024		
	DANFOSS	151-2501	151-2502	151-2503	151-2504	151-2505	151-2506	151-2507	151-2508	151-2509	151-2509		
CHIEF	BMRS-50-H4-S-P	BMRS-80-H4-S-P	BMRS-100-H4-S-P	BMRS-125-H4-S-P	BMRS-160-H4-S-P	BMRS-200-H4-S-P	BMRS-250-H4-S-P	BMRS-315-H4-S-P	BMRS-375-H4-S-P	ADM400-4SP	103-1056		
PRINCE	AEM50-4SP	AEM75-4SP	AEM100-4SP	N/A	AEM150-4SP	AEM200-4SP	AEM250-4SP	AEM300-4SP	103-1056	151-2439	103-1056		
CHAR-LYNN®	103-1049	103-1050	103-1051	101-1766	103-1052	103-1053	103-1054	103-1055	103-1056	103-1056			
DANFOSS	151-2431	151-2432	151-2433	151-2434	151-2435	151-2436	151-2437	151-2438	151-2439	151-2439			
CHIEF	BMRS-50-H4-S-S	BMRS-80-H4-S-S	BMRS-100-H4-S-S	BMRS-125-H4-S-S	BMRS-160-H4-S-S	BMRS-200-H4-S-S	BMRS-250-H4-S-S	BMRS-315-H4-S-S	BMRS-375-H4-S-S	ADM400-4SO	103-1064		
PRINCE	AEM50-4SO	AEM75-4SO	AEM100-4SO	N/A	AEM150-4SO	AEM200-4SO	AEM250-4SO	AEM300-4SO	103-1064	151-2359	103-1064		
CHAR-LYNN®	103-1057	103-1058	103-1059	103-1872	103-1060	103-1061	103-1062	103-1063	103-1064	103-1064			
DANFOSS	151-2351	151-2352	151-2353	151-2354	151-2355	151-2356	151-2357	151-2358	151-2359	151-2359			
CHIEF	BMRS-50-H4-S-F	BMRS-80-H4-S-F	BMRS-100-H4-S-F	BMRS-125-H4-S-F	BMRS-160-H4-S-F	BMRS-200-H4-S-F	BMRS-250-H4-S-F	BMRS-315-H4-S-F	BMRS-375-H4-S-F	ADM400-4ST	103-1072		
PRINCE	AEM50-4ST	AEM75-4ST	AEM100-4ST	N/A	AEM150-4ST	AEM200-4ST	AEM250-4ST	AEM300-4ST	103-1072	151-2519	103-1072		
CHAR-LYNN®	103-1065	103-1066	103-1067	103-1770	103-1068	103-1069	103-1070	103-1071	103-1072	103-1072			
DANFOSS	151-2511	151-2512	151-2513	151-2514	151-2515	151-2516	151-2517	151-2518	151-2519	151-2519			
CHIEF	BMRS-50-H2-K-P	BMRS-80-H2-K-P	BMRS-100-H2-K-P	BMRS-125-H2-K-P	BMRS-160-H2-K-P	BMRS-200-H2-K-P	BMRS-250-H2-K-P	BMRS-315-H2-K-P	BMRS-375-H2-K-P	ADM400-2RP	103-1032		
PRINCE	AEM50-2RP	AEM75-2RP	AEM100-2RP	N/A	AEM150-2RP	AEM200-2RP	AEM250-2RP	AEM300-2RP	103-1032	151-2389	103-1032		
CHAR-LYNN®	103-1025	103-1026	103-1027	103-1706	103-1028	103-1029	103-1030	103-1031	103-1032	103-1032			
DANFOSS	151-2381	151-2382	151-2383	151-2384	151-2385	151-2386	151-2387	151-2388	151-2389	151-2389			
CHIEF	BMRS-50-H2-K-S	BMRS-80-H2-K-S	BMRS-100-H2-K-S	BMRS-125-H2-K-S	BMRS-160-H2-K-S	BMRS-200-H2-K-S	BMRS-250-H2-K-S	BMRS-315-H2-K-S	BMRS-375-H2-K-S	ADM400-2RO	103-1040		
PRINCE	AEM50-2RO	AEM75-2RO	AEM100-2RO	N/A	AEM150-2RO	AEM200-2RO	AEM250-2RO	AEM300-2RO	103-1040	151-2309	103-1040		
CHAR-LYNN®	103-1033	103-1034	103-1035	103-1702	103-1036	103-1037	103-1038	103-1039	103-1040	103-1040			
DANFOSS	151-2301	151-2302	151-2303	151-2304	151-2305	151-2306	151-2307	151-2308	151-2309	151-2309			
CHIEF	BMRS-50-H2-K-F	BMRS-80-H2-K-F	BMRS-100-H2-K-F	BMRS-125-H2-K-F	BMRS-160-H2-K-F	BMRS-200-H2-K-F	BMRS-250-H2-K-F	BMRS-315-H2-K-F	BMRS-375-H2-K-F	ADM400-4RT	103-1048		
PRINCE	ADM50-4RT	AEM75-4RT	AEM100-4RT	N/A	AEM150-4RT	AEM200-4RT	AEM250-4RT	AEM300-4RT	103-1048	151-2467	103-1048		
CHAR-LYNN®	103-1041	103-1042	103-1043	103-11710	103-1044	103-1045	103-1046	103-1047	103-1048	103-1048			
DANFOSS	151-2461	151-2462	151-2463	151-2464	151-2465	151-2466	151-2467	151-2468	151-2469	151-2467			
CHIEF	BMRS-50-H2-S-P	BMRS-80-H2-S-P	BMRS-100-H2-S-P	BMRS-125-H2-S-P	BMRS-160-H2-S-P	BMRS-200-H2-S-P	BMRS-250-H2-S-P	BMRS-315-H2-S-P	BMRS-375-H2-S-P	ADM400-2SP	103-1080		
PRINCE	AEM50-2SP	AEM75-2SP	AEM100-2SP	N/A	AEM150-2SP	AEM200-2SP	AEM250-2SP	AEM300-2SP	103-1080	151-2399	103-1080		
CHAR-LYNN®	103-1073	103-1074	103-1075	103-1727	103-1076	103-1077	103-1078	103-1079	103-1080	103-1080			
DANFOSS	151-2391	151-2392	151-2393	151-2394	151-2395	151-2396	151-2397	151-2398	151-2399	151-2399			
CHIEF	BMRS-50-H2-S-S	BMRS-80-H2-S-S	BMRS-100-H2-S-S	BMRS-125-H2-S-S	BMRS-160-H2-S-S	BMRS-200-H2-S-S	BMRS-250-H2-S-S	BMRS-315-H2-S-S	BMRS-375-H2-S-S	ADM400-2SO	103-1088		
PRINCE	ADM50-2SO	AEM75-2SO	AEM100-2SO	N/A	AEM150-2SO	AEM200-2SO	AEM250-2SO	AEM300-2SO	103-1088	151-2318	103-1088		
CHAR-LYNN®	103-1081	103-1082	103-1083	103-1723	103-1084	103-1085	103-1086	103-1087	103-1088	103-1088			
DANFOSS	151-2311	151-2312	151-2313	151-2314	151-2315	151-2316	151-2317	151-2318	151-2319	151-2318			
CHIEF	BMRS-50-H2-S-F	BMRS-80-H2-S-F	BMRS-100-H2-S-F	BMRS-125-H2-S-F	BMRS-160-H2-S-F	BMRS-200-H2-S-F	BMRS-250-H2-S-F	BMRS-300-H2-S-F	BMRS-375-H2-S-F	ADM400-2ST	103-1096		
PRINCE	ADM50-2ST	AEM75-2ST	AEM100-2ST	N/A	AEM150-2ST	AEM200-2ST	AEM250-2ST	AEM300-2ST	103-1096	151-2478	103-1096		
CHAR-LYNN®	103-1089	103-1090	103-1091	103-1731	103-1092	103-1093	103-1094	103-1095	103-1096	103-1096			
DANFOSS	151-2471	151-2472	151-2473	151-2474	151-2475	151-2476	151-2477	151-2478	151-2479	151-2479			

Char-Lynn® is a registered trademark of the Eaton Corporation.

Note: The cross reference information in this chart is to be used only as a reference for guideline purposes only. After selecting a model from above, review motor specifications to determine compatibility with specific application.