

Charleston

Model # 5857

Charleston Mail Post



DESCRIPTION

The Charleston mail post will add curb appeal to any home. Design features include decorative molding details, inset panels, and arched mailbox arm support.

- Weather resistant, low maintenance material
- Installs easily over a standard 4x4 wood post
- Recommended for mailboxes up to 8lbs
- 100% high-grade polyethylene with built in UV inhibitors
- Warranty: 15-Yr Residential Use / 5-Yr Commercial Use

PRODUCT DIMENSIONS

Outside Dimensions: 25.5in L x 9in W x 58in H (64.9cm x 22.9cm x 147.3cm)

Wall Thickness: 0.125in (3.17mm)

Part Weight: 11lbs (5kg)

Material: Polyethylene

Contents: Post, Support Arm, and Hardware

Note: 4x4 wood post, mailbox, and mailbox mounting hardware NOT included

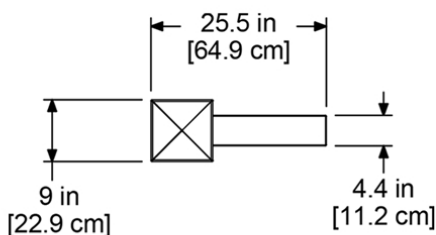
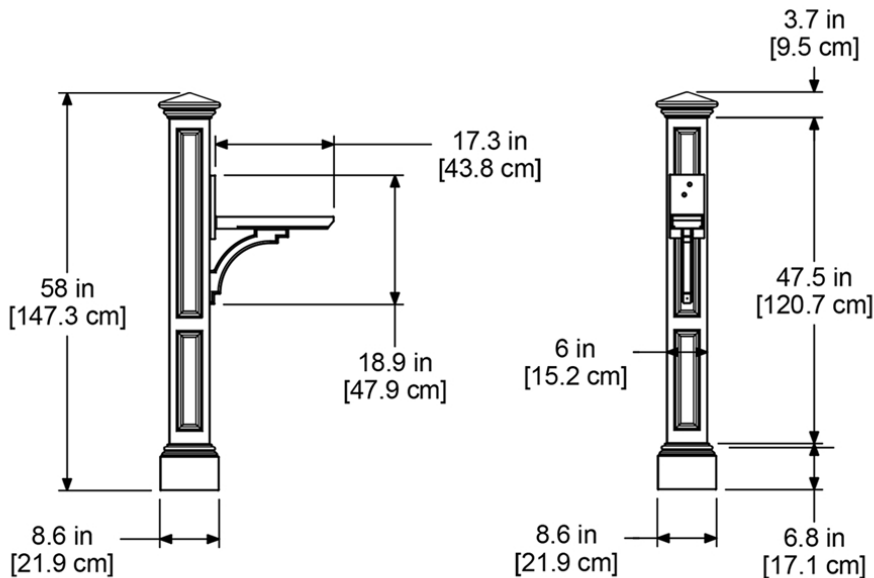

MAYNE[®]
Outdoor Products of Distinction

7024 Kilbourne Rd - Unit A London, ON N6P 1K6

Tel: 866-363-8834 | www.gomayne.com

customerservice@gomayne.com