



## Instructions for 15-Gallon Directional Feeder

THANK YOU for your purchase of the 15-Gallon Directional Feeder. Please read this sheet before operating the unit. If you should have any questions about this product or any other Moultrie product, please contact us using the information on the back of this sheet. To help us to better serve you, please submit your warranty information online at <http://www.moultriefeeders.com/warranty>

### I ATTACH TREE BRACKET TO HOPPER

- 1 Insert 5/16" x 2 1/2" black oxide bolt through Standoff, Square Tube, Hopper, Curved Plate and 1/4" washer as shown.
- 2 Fasten with nut.
- 3 Repeat for bottom with Curved Plate between Square Tube and Hopper as shown.

### II MOUNT ADAPTER TO HOPPER

- 1 Turn hopper upside down and align "X" on Feeder Adapter with "X" on hopper bottom.
- 2 Fasten with (4) 8/32" bolts, nuts and washers.

### III MOUNT FEEDER KIT

- 1 Align Feeder Kit so that the shroud is aiming opposite the Tree Bracket as shown (Figure 1).
- 2 Fasten kit to Feeder Adapter using 1/4" bolts, washers and nuts.

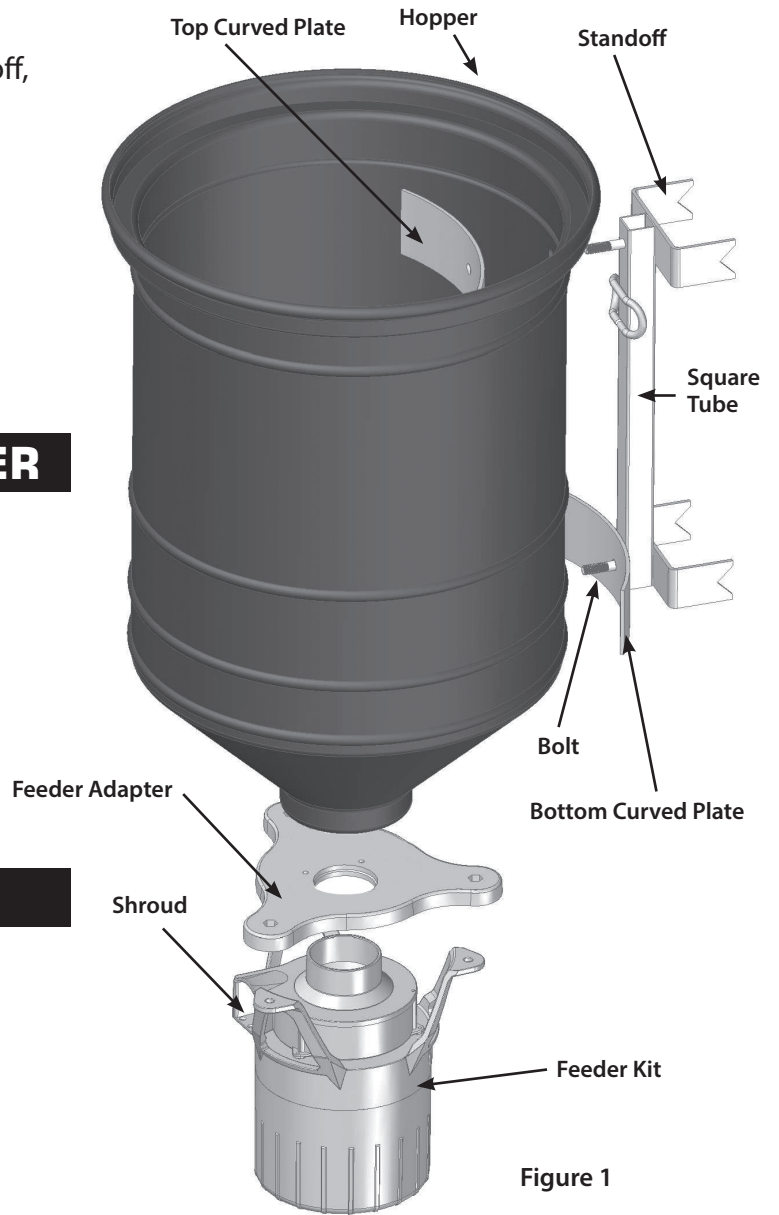

### IV MOUNT FEEDER TO TREE

- 1 Strap Feeder to tree using provided ratchet strap. Attach ratchet strap to Tree Bracket wire loop (Figure 2).

**NOTE: Hooks must be attached as shown with hook facing away from tree.**

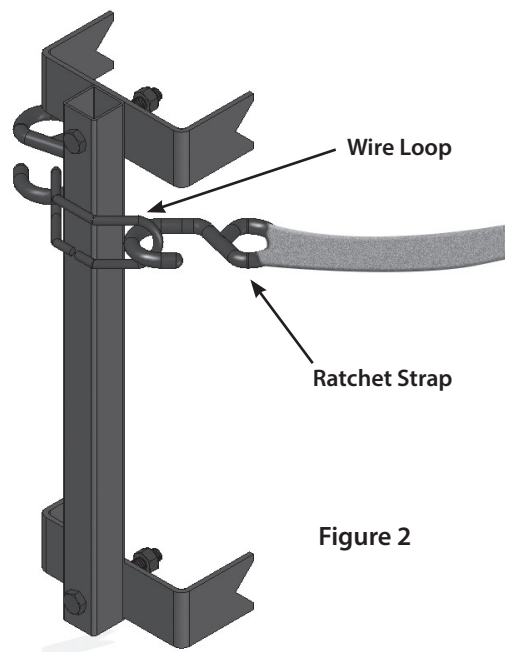

Our Service Department will gladly answer any questions you have. Call **800-653-3334**, Monday - Friday, 8:00 AM to 5:00 PM CST.

[www.moultriefeeders.com](http://www.moultriefeeders.com)