

Installation Instructions

P45AC6 Air Compensated Pintle Hook

Rigid type pintle hook with air actuated plunger. The plunger provides minimum clearance with some shock absorption.

⚠ WARNING

Maintain adequate vertical (tongue) load to properly control the trailer (generally 10%) but do not exceed the above rated capacities.

Capacity

18,000 lbs. Maximum vertical load
 90,000 lbs. Maximum gross trailer weight (120,000 tensile)

Towing Applications

Trailer, full trailers, and doubles operating within the stated capacities. Reduce capacities by 25% for off road applications and use with swivel type drawbar.

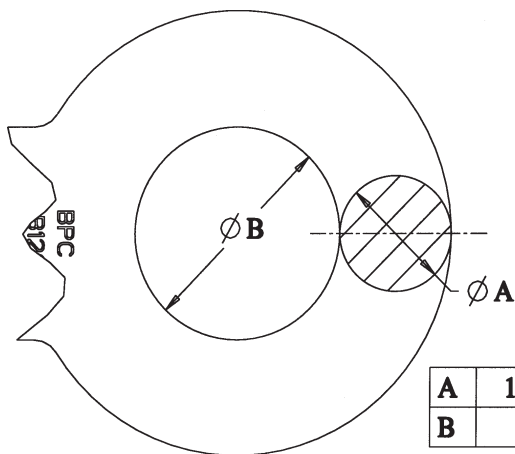

Drawbar Eye Dimensions

2-3/8" to 3" I.D. with 1-5/8" to 1-3/4" section.

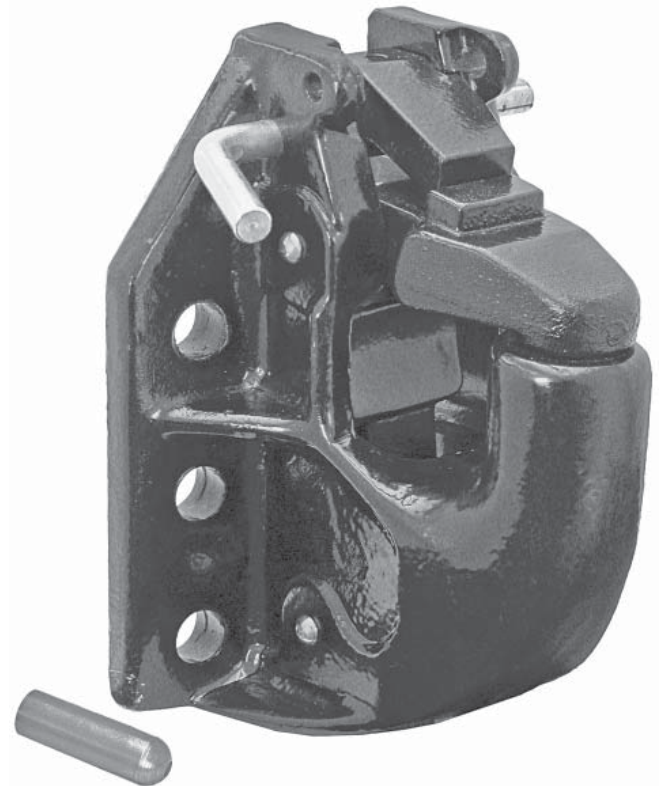

Mounting Instructions

In order to perform this repair, it will be necessary to remove the hook from the vehicle.

1. Use a mounting structure of sufficient strength to support the rated capacity of the pintle hook in accordance with SAE J849B.
2. Use hole pattern dimensions described in "General Dimensions"
3. Determine the cut length for the air chamber rod and cut rod (see steps 3a and 3b). Assemble jam nut to the rod before cutting and remove after cutting to clean up any damaged threads.

⚠ WARNING

This hitch must be used with an air brake chamber.

3a. When using Buyers mount bracket, P45AC6BK, determine the cut length as follows:

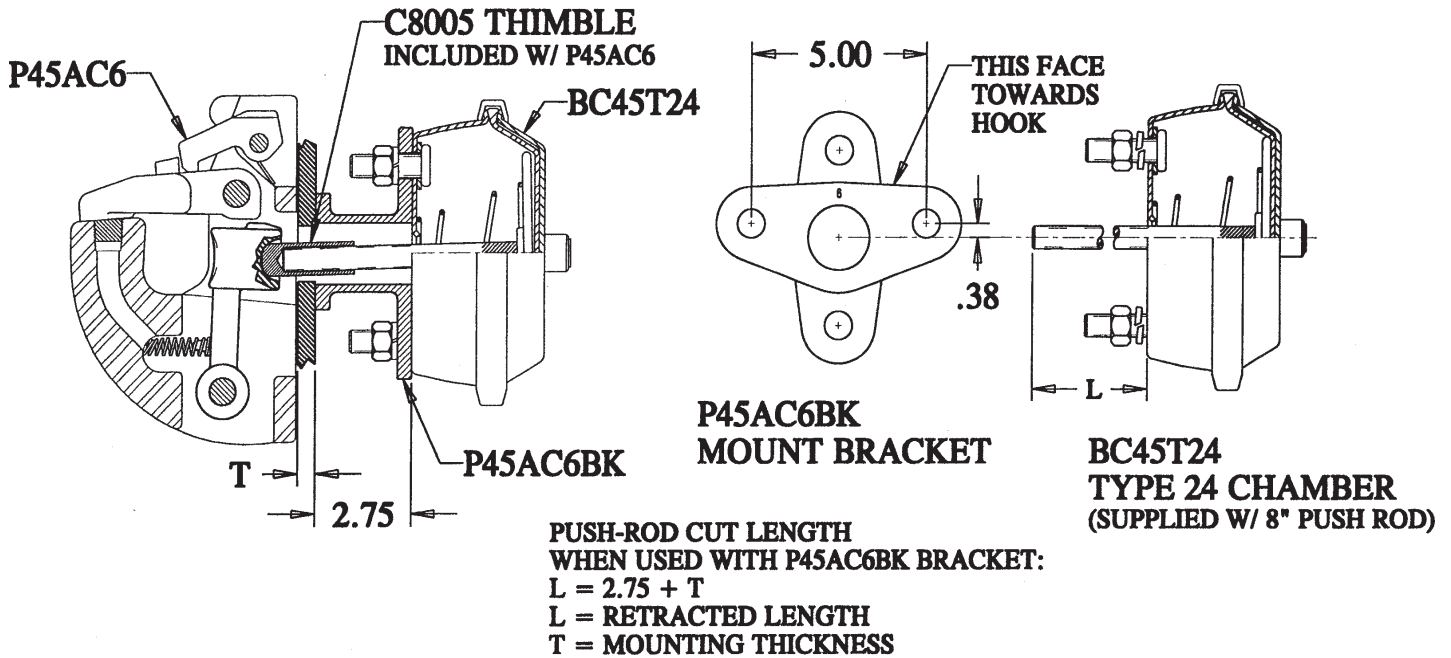

3b. When using any other air chamber mounting structure, determine the cut length as follows:

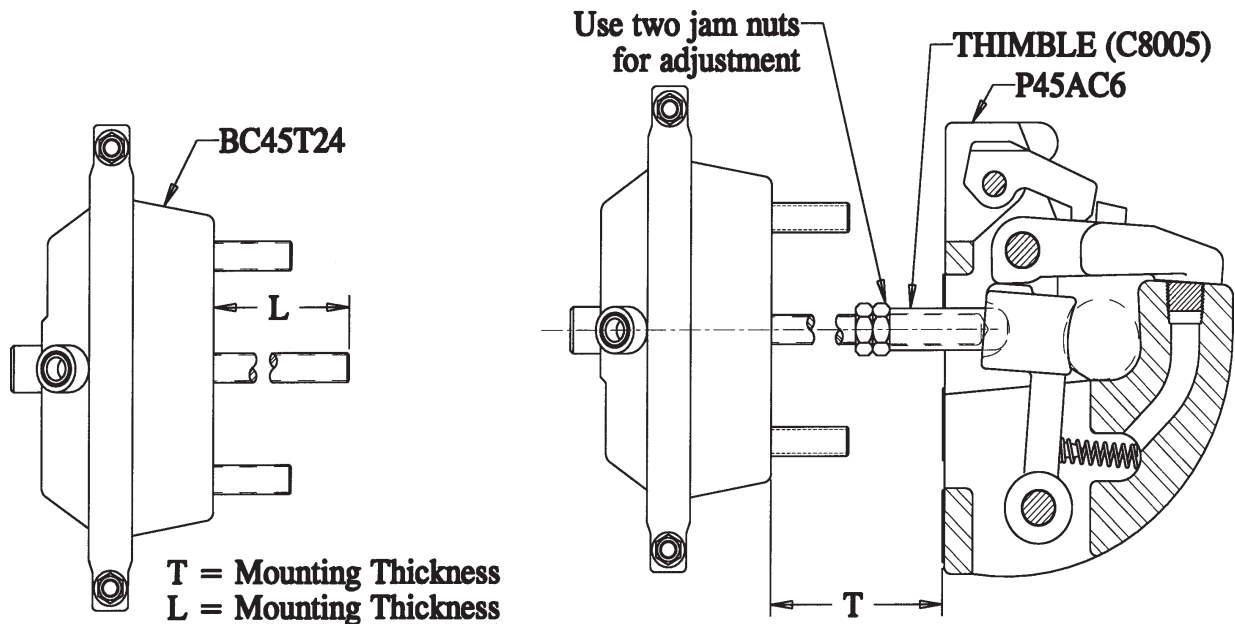

4. Assemble the air chamber to the P45AC6BK mount bracket or custom mount structure. Torque fasteners to 133-155 ft/lbs.

5. Install pintle hook four 3/4" grade 8 screws and nuts in the hitch's bottom four holes and hand tighten. Assemble thimble to the end of the chamber rod. Assemble the air chamber assembly to hitch using the top two holes and two more 3/4" grade 8 screws. Tighten all screws properly. Torque plain screws to 375 ft/lbs.

6. Check hitch for proper operation by extending and retracting plunger.

Operating Instructions

- 1.** Before operating, inspect hitch assembly for proper operation, worn, damaged or missing parts. Correct any flaws prior to use.
- 2.** Verify that the plunger is retracted. Release air pressure to retract plunger, if necessary.
- 3.** Open latch by pulling handle and rotating it upward. While holding the handle up, lift the jaw and hook it open on the lock.
- 4.** Lower drawbar eye over the horn of the pintle.
- 5.** Close jaw and lock. Verify that the lock slides completely into pocket.

Maintenance Instructions

- 1.** Clean and check for proper operation.
- 2.** Inspect and replace worn, damaged or missing parts.
- 3.** Keep all pivot points well lubricated with light oil.
- 4.** Check mounting bolts for proper torque.
- 5.** Check for proper plunger adjustment.

General Dimensions

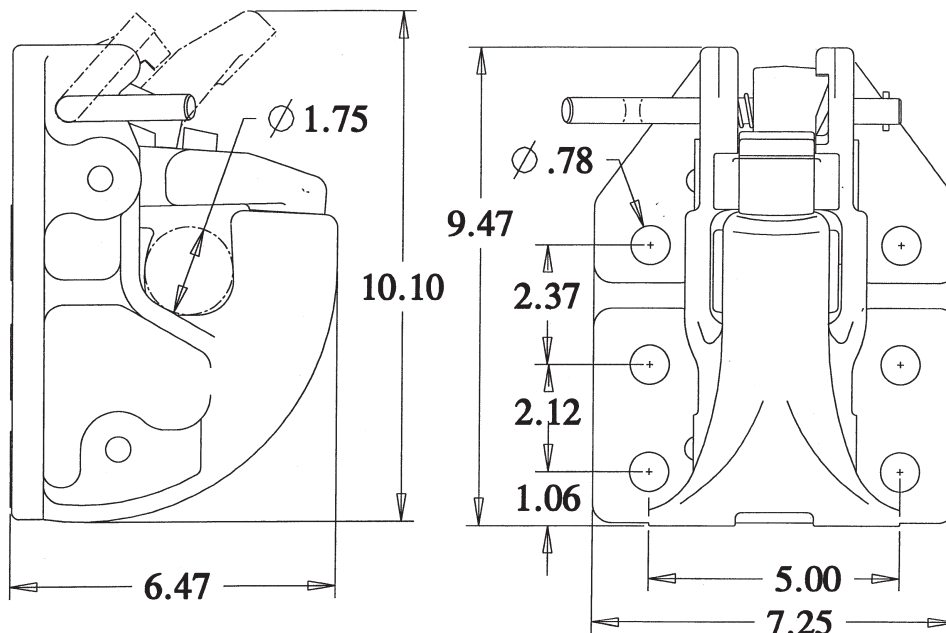

WARNING

Other steps and inspections are also required. Consult D.O.T. regulations and The American Trucking Association for complete coupling and uncoupling procedures.

Replacement Parts Kit

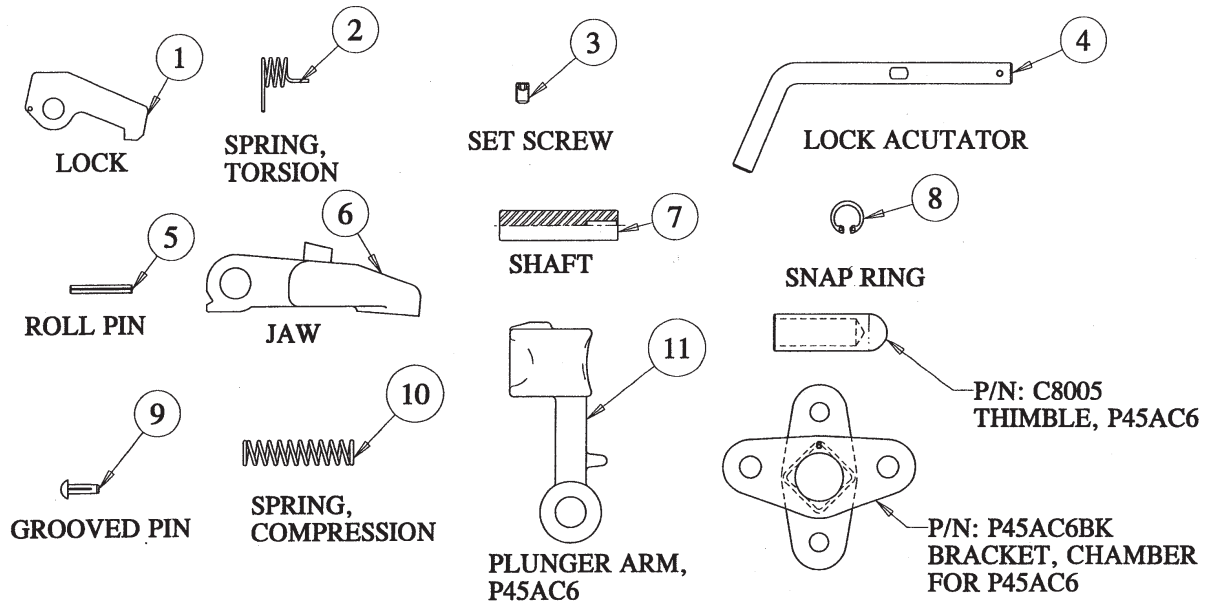

REPLACEMENT PART KITS		ITEM QUANTITY										
KIT NO:	DESCRIPTION	1	2	3	4	5	6	7	8	9	10	11
C6200	KIT, P45AC6 JAW REPLACEMENT	-	-	-	-	1	1	2	2	2	1	1
C6300	KIT, P45AC6 LOCK REPLACEMENT	1	1	1	-	1	-	-	-	-	-	-
C6400	KIT, P45AC6 REBUILD	1	1	1	1	1	1	2	2	2	1	1

Hole Pattern

Pattern drawing not to size.

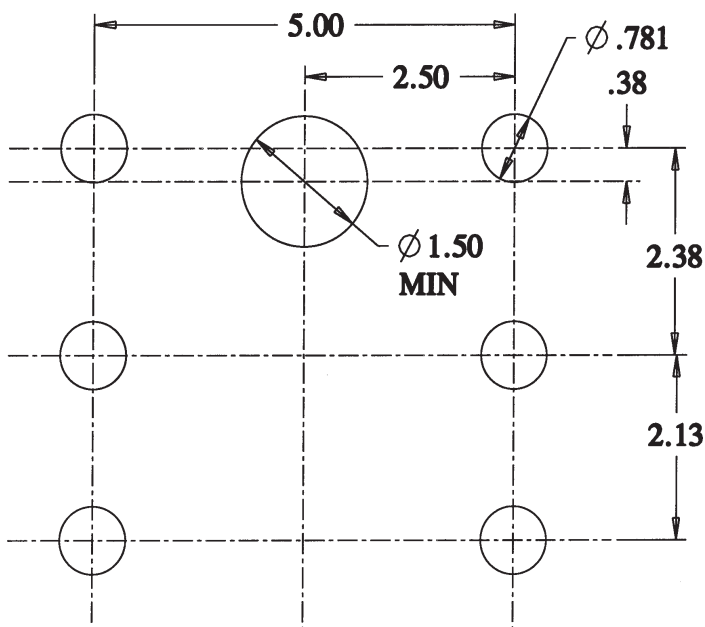

Warranty

Buyers Products Co. warrants all truck/trailer hardware manufactured or distributed by it, to be free from defects in material and workmanship for a period of one year from date of shipment. Parts must be properly installed and used under normal conditions. Any product which has been altered, including modification, misuse, accident or lack of maintenance will not be considered under warranty. Normal wear is excluded. The sole responsibility of Buyers Products Co. under this warranty is limited to repairing or replacing any part or parts which are returned, prepaid, and are found to be defective by Buyers Products Co. Authorization from Buyers Products Co. must be obtained before returning any part. No charges for transportation or labor performed on Buyers' products will be allowed under this warranty.