

Installation Instructions

BP225 25-Ton Pintle Hook

Capacity

6,000 lbs. Maximum Vertical Load

50,000 lbs. Maximum Gross Trailer Weight

⚠ WARNING

Maintain adequate vertical (tongue) load to properly control the trailer (generally 10%) but do not exceed the above rated capacities.

Description

Swivel type pintle hook with spring cushion. Swivel provides torsional relief and spring provides some shock absorption at coupling.

Towing Applications

Use with trailers and equipment designed for over the road towing within the stated capacities. Use only with non-swivel type drawbar. This pintle hook is ideal for use in the utility and construction industries. For off road applications reduce the stated capacities by 25%.

Drawbar Eye Dimension

2-3/8" to 3" I.D. with 1-1/4" to 1-5/8" diameter section.

Mounting

1. Use a mounting structure of sufficient strength to support the rated capacity of the pintle hook in accordance with SAE J849B.
2. Use the hole pattern described on the reverse.
3. Install using eleven - 1/2" grade 8 bolts properly tightened. A lug is provided for the attachment of braces (see back of page).
4. Tighten nut to slightly compress spring and assemble cotter pin in nut castellation. Spread cotter pin.

Operating Instructions

1. Before operating check for proper operation, worn, damaged or missing parts and secure mounting. Correct flaws before use.

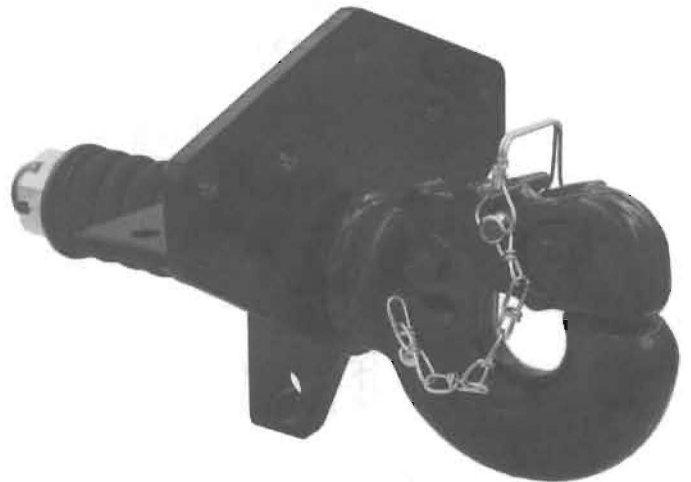

2. Move pintle to correct coupling position as shown above. (Latch on top)

3. Open latch by removing safety pin and lifting lock.

4. Lower drawbar eye over the horn on the pintle.

WARNING: Do not damage latch. Be careful with the drawbar when coupling and uncoupling.

5. Close latch and insert safety pin.

⚠ WARNING

Other steps and inspections are also required. Consult D.O.T. regulations and American Trucking Association for complete coupling and uncoupling procedures.

Maintenance Checklist

1. Clean and check for proper operation.
2. Inspect for worn damaged or missing parts. Replace when needed.
3. Lubricate latch with light oil. Grease zerk in mounting bracket.
4. Check mounting bolts for proper torque.

General Information

1. Do not modify or add to the product.
2. Wear safety glasses during installation, removal and rebuilding.
3. Never strike any part with steel hammer.
4. Do not weld on this product without written consent from Buyers Products Company.

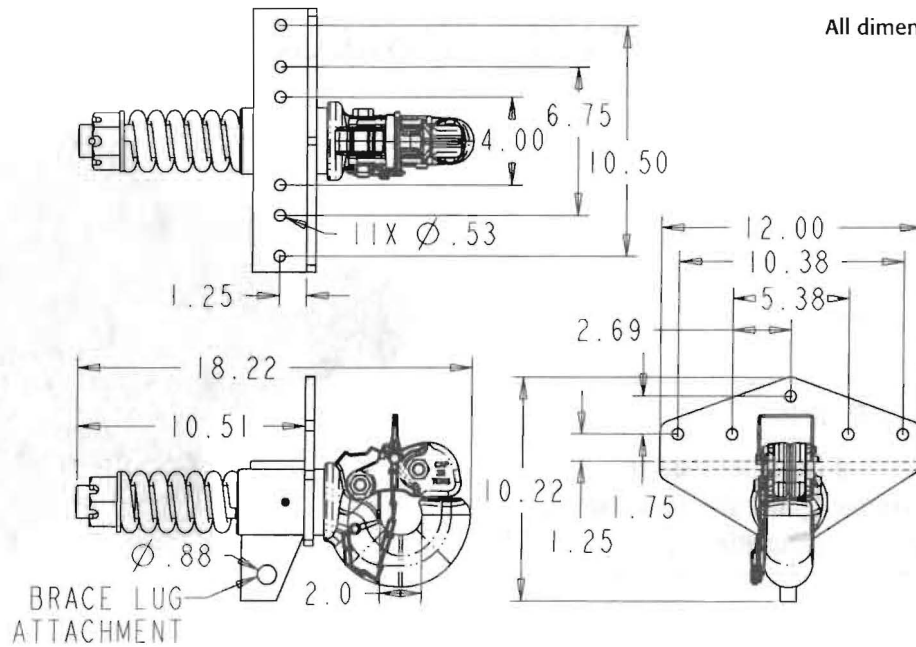

All dimensions shown are nominal

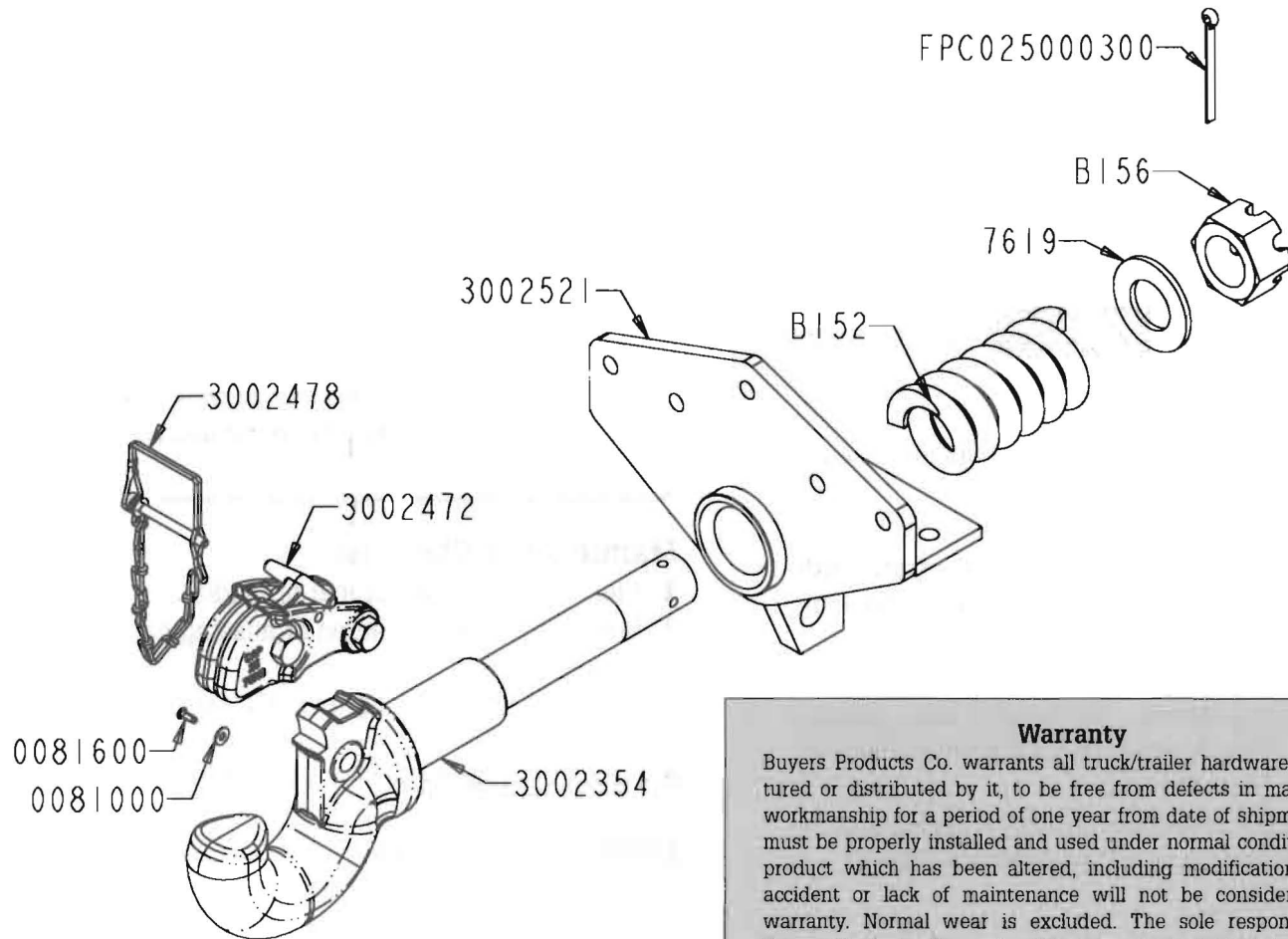

Warranty

Buyers Products Co. warrants all truck/trailer hardware manufactured or distributed by it, to be free from defects in material and workmanship for a period of one year from date of shipment. Parts must be properly installed and used under normal conditions. Any product which has been altered, including modification, misuse, accident or lack of maintenance will not be considered under warranty. Normal wear is excluded. The sole responsibility of Buyers Products Co. under this warranty is limited to repairing or replacing any part or parts which are returned, prepaid, and are found to be defective by Buyers Products Co. Authorization from Buyers Products Co. must be obtained before returning any part. No charges for transportation or labor performed on Buyers' products will be allowed under this warranty.