

# Barn Style Flight Cage

Model: # 41618

## read first REVIEW BEFORE ASSEMBLY

- **TOOLS:** No tools are required. For assistance or replacement parts, please contact Prevue **TOLL-FREE** 800.243.3624 **ONLINE** [www.prevuepet.com](http://www.prevuepet.com)

### step 1 PARTS USED:

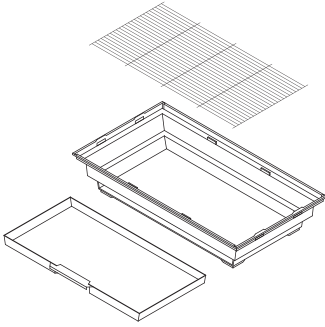

Removable tray will already be in the base.

Place grille into base before adding mesh.

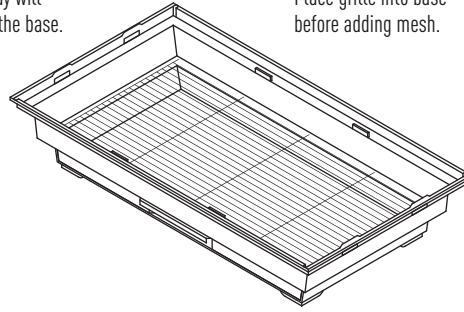

### step 2 PARTS USED:

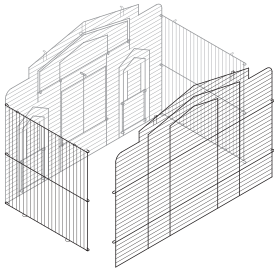

Create the cage body by beginning at the bottom corner and hooking the panels together (arrow #1).

Weave the alternating hooks together up the seam (arrows #2-5) by flexing the mesh panels.

Follow the same method for the other seam (arrows #6-10).

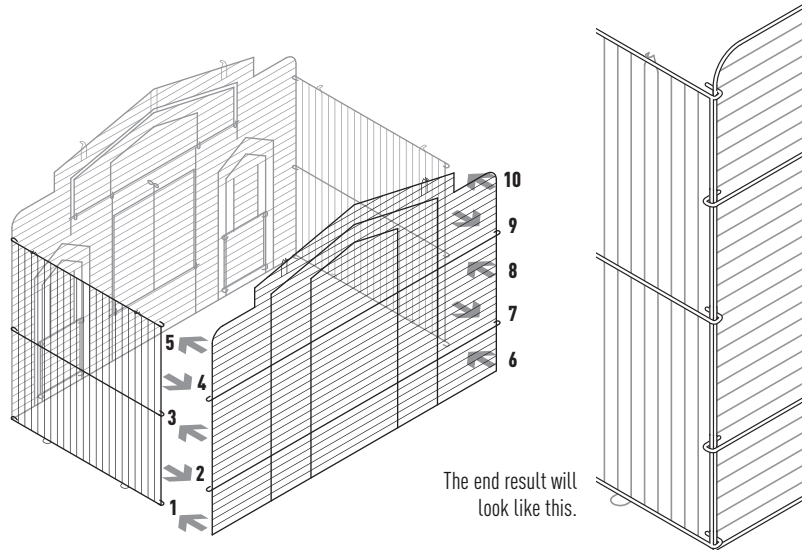

The end result will look like this.

### step 3

Place the completed cage mesh unit into the base. Starting at one end, align the loops on the mesh with openings in the base. Guide the mesh in place between the edge and the tabs along the inner rim of the base.

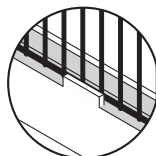

Finish with putting the loops into the base openings on the opposite end.

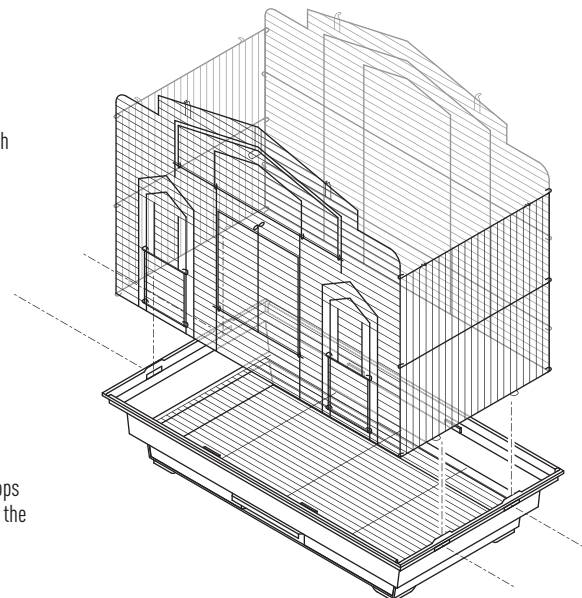

## step 4 PARTS USED:

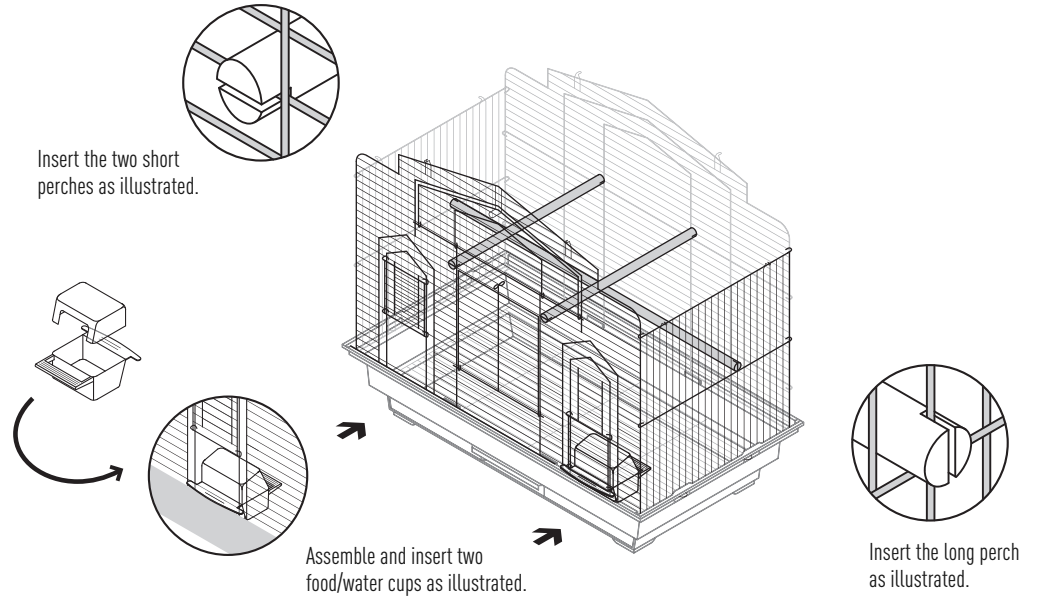
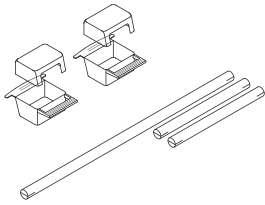

## step 5 PARTS USED:

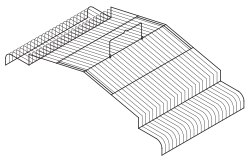

Catch the roof on the loops, beginning at one end, working along the front and back, and finishing at the opposite end.

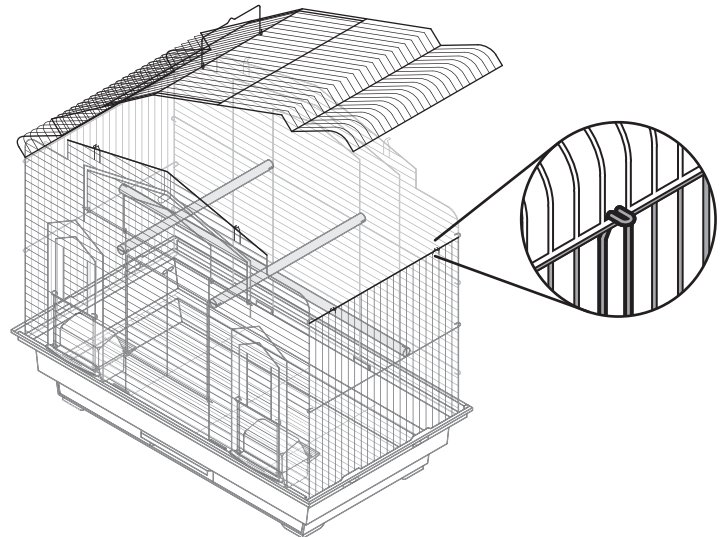

### CLEANING INSTRUCTIONS

Prolong the life of your Prevue cage with these recommendations:

- When cleaning the cage and parts, use a soft cloth or Teflon-resistant scrubber (such as Prevue's **Cage Saver** non-abrasive scrub pad (#109)).
- Wash all parts with warm water and a mild environmentally-friendly, pet-friendly soap.
- Rinse thoroughly.
- Hand dry all parts completely with a soft dry cotton cloth before reassembling the cage.
- Do not leave plastic parts to dry in the sun as they may warp.

