

ASSEMBLY INSTRUCTIONS

The Luxembourg Privacy Screen (Pre-Assembled)

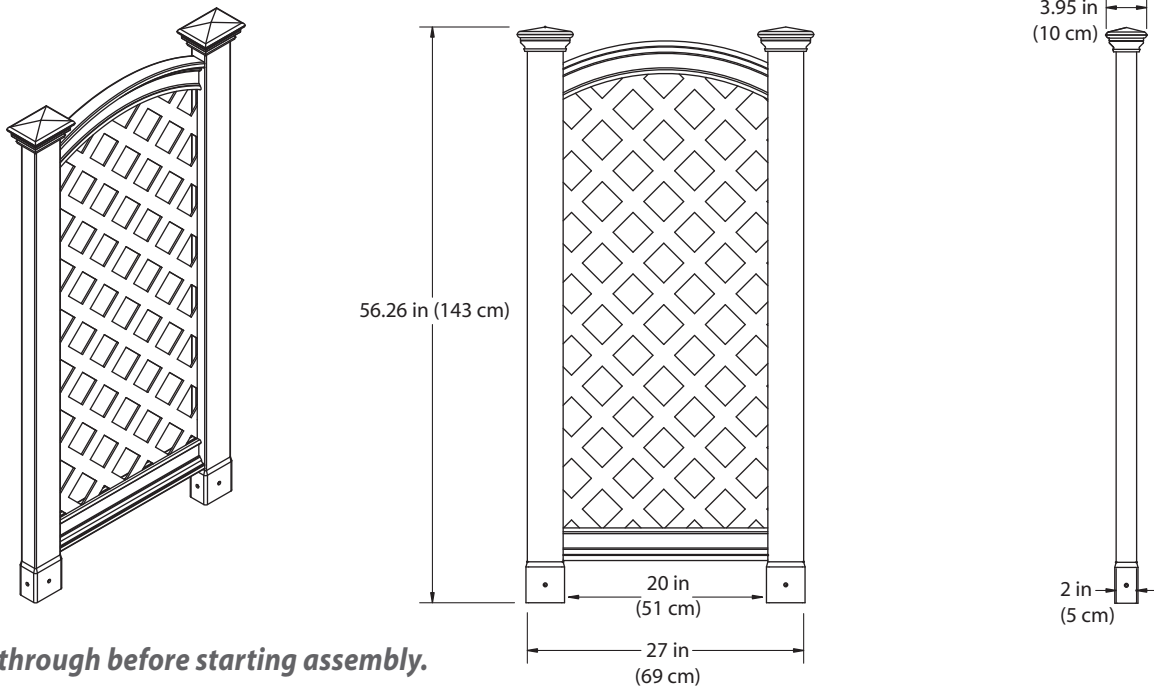

Please read through before starting assembly.

Check Box for These Contents

In the event of missing or defective parts please call our customer service dept. at **1 800 282 9346** (Mon. to Fri. 8:00 AM to 5:00 PM EST).

1. Pre-Assembled Luxembourg Privacy Screen (1)
2. Post Caps (2) - 10611
3. Ground Mounting Extensions (2) - 10636-1
4. 5/8" Self-Auguring Stainless Steel Screws (8) - 20016

Tools You Will Need

- Cordless Drill
- Hammer
- Tape Measure
- Level
- Shovel

General Information

- **Read Instructions through carefully before beginning assembly.**
- When assembling components, place on a non-abrasive surface (i.e. shipping box) to avoid scratching.
- We recommend an area approx 10' x 8' (3 m x 2.4 m) for unobstructed assembling.
- You should not need to use excessive force when assembling components.

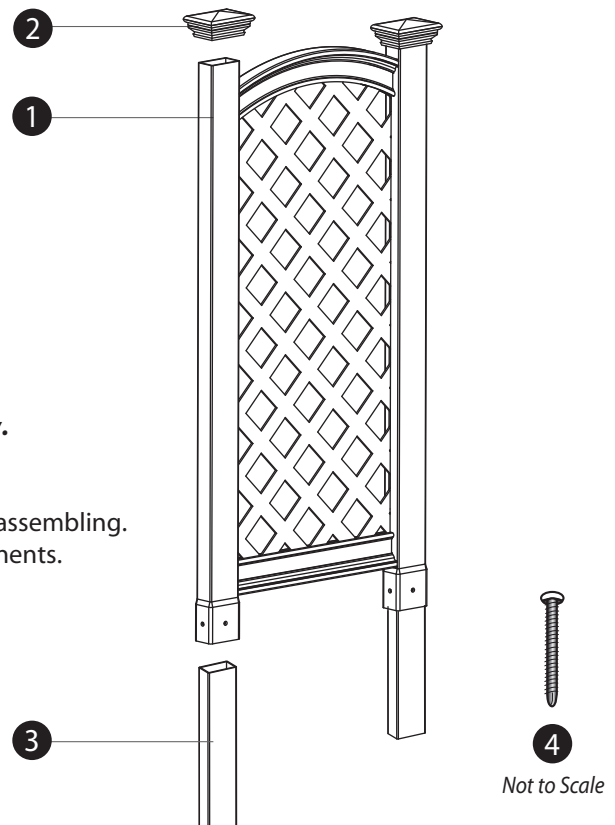

Mounting Into the Ground

Privacy screens must be well secured in the event of high winds, etc. We have provided two ground mounting extensions for securing the privacy screen either into the ground or into a concrete footing. If you are installing your trellis on concrete or a deck, see your hardware store for the appropriate galvanized bracket hardware.

STEP ONE

Install the Ground Anchor Stakes

Insert the ground mounting extensions into the bottom of the privacy screen posts. Secure with screws into the four pre-drilled holes.

STEP TWO

Install Trellis into Ground

A

Move the screen to its final location. When you are satisfied with the location, mark the positions of the posts, then move the screen aside and lay it carefully on its side. Excavate the 2 post holes approximately 18" (46 cm) deep x 6" (15 cm) diameter.

Carefully move the screen back into position.

B

Level it both vertically and horizontally into the excavated holes.

C

Backfill the holes with the excavated soil.

STEP THREE

Install the Post Caps

OPTIONAL

Mounting to Barcelona Planter Box

(Purchase Separately)

Please see instructions illustrated with the planter box.

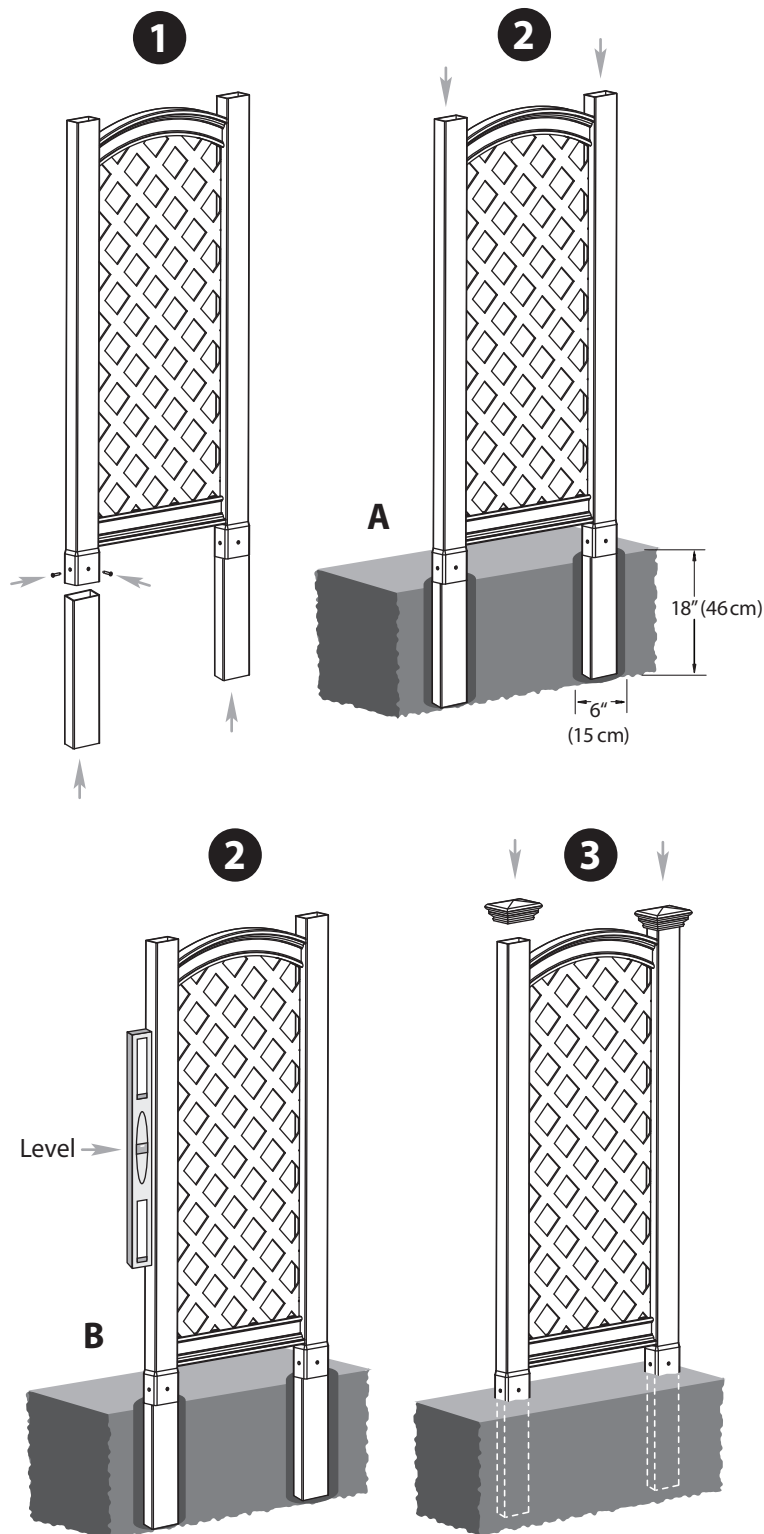

vita