

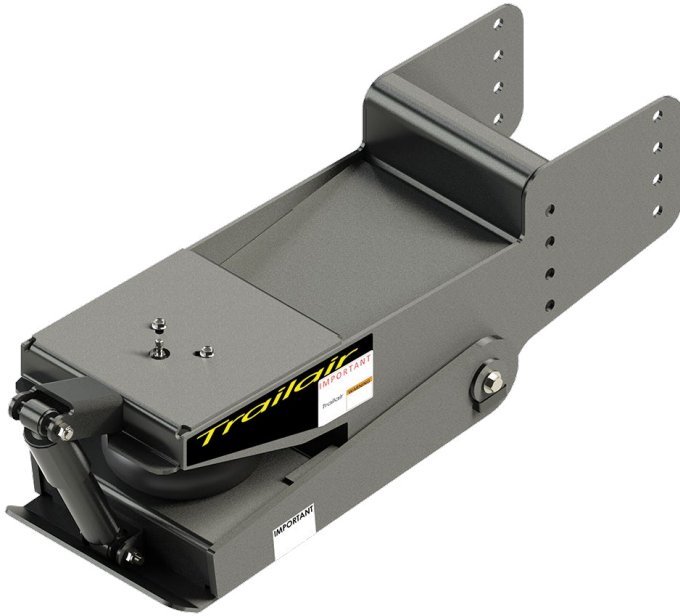

LIPPERT
COMPONENTS®

AirRide™



Air Ride™ Pin Box Installation and Owner's Manual

(For Aftermarket Applications)

Table of Contents

Introduction	2
Safety	2
Parts List	2
Resources Required	2
Installation	3
Operation	4
Pull Test	4
Troubleshooting	5
Maintenance	6
Notes	6

Air Ride Pin Box Kits	
Part #	Description
155925	21K L03 Air Ride Pin Box
158778	21K L05 Air Ride Pin Box
158777	21K L07 Air Ride Pin Box
179879	18K M15 Air Ride Pin Box
155943	21K M19 Air Ride Pin Box



Air Ride™ Pin Box

Installation and Owner's Manual

(For Aftermarket Applications)

Introduction

Trailair was first-to-market with Air Ride™ for 5th Wheels and still leads the way with innovative 5th Wheel pin box technology. The new Air Ride Pin Box uses time-tested Trailair air ride technology to provide an unparalleled ride, eliminating chucking and the vertical tug-of-war between the 5th Wheel and tow vehicle.

Additional information about this product can be obtained from lci1.com/support or by using the myLCI app. Replacement kits can be ordered from <https://store.lci1.com/> or by using the myLCI app.

The myLCI app is available for free on iTunes® for iPhone® and iPad® and also on Google Play™ for Android™ users.

iTunes®, iPhone®, and iPad® are registered trademarks of Apple Inc.

Google Play™ and Android™ are trademarks of Google Inc.

Safety

Read and fully understand all instructions before installing or operating this product.

Adhere to all safety labels.

⚠ WARNING

THE "WARNING" SYMBOL ABOVE IS A SIGN THAT A PROCEDURE HAS A SAFETY RISK INVOLVED THAT MAY CAUSE DEATH, SERIOUS PERSONAL INJURY, SEVERE PRODUCT AND/OR PROPERTY DAMAGE IF NOT PERFORMED SAFELY AND WITHIN THE PARAMETERS SET FORTH WITHIN THIS MANUAL.

⚠ CAUTION

THE "CAUTION" SYMBOL ABOVE IS A SIGN THAT A PROCEDURE HAS A RISK INVOLVED THAT MAY CAUSE PERSONAL INJURY AND/OR PRODUCT DAMAGE IF NOT PERFORMED SAFELY AND WITHIN THE PARAMETERS SET FORTH WITHIN THIS MANUAL.

Make sure pin box is sufficiently and properly supported before removing mounting hardware.

Prior to new pin box installation, make sure air bag on new pin box is not overinflated.

Parts List

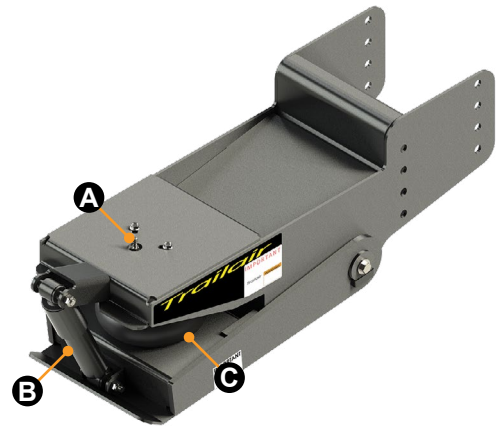

NOTE: Part numbers are shown for identification purposes only. Not all parts are available for individual sale. All parts with a link to the Lippert Store can be purchased.

Letter	PN	Description
A	156740	Tank Valve
B	177223	Oil Shock
C	432404	Air Spring

Resources Required

- 2-3 people, depending on task
- Safety glasses
- Tape measure
- Air compressor
- Wrench and socket set
- Box end wrenches
- Level



Air Ride™ Pin Box Installation and Owner's Manual (For Aftermarket Applications)

Installation

NOTE: The pin box assembly weighs several hundred pounds. A minimum of two people are required to complete the removal and installation of the pin boxes. A forklift may be used to lift the pin box into position.

NOTE: The 5th Wheel should always be towed while level. Adjustment of the pin box mounting height, the tow vehicle height or suspension may be necessary to accomplish a level towing condition.

⚠ CAUTION

MOVING PARTS CAN PINCH, CRUSH OR CUT. KEEP CLEAR AND USE CAUTION.

1. Level the trailer front-to-back.
2. Measure from the ground to the bottom of the kingpin plate on the current pin box. Record this dimension as A (Fig.1).

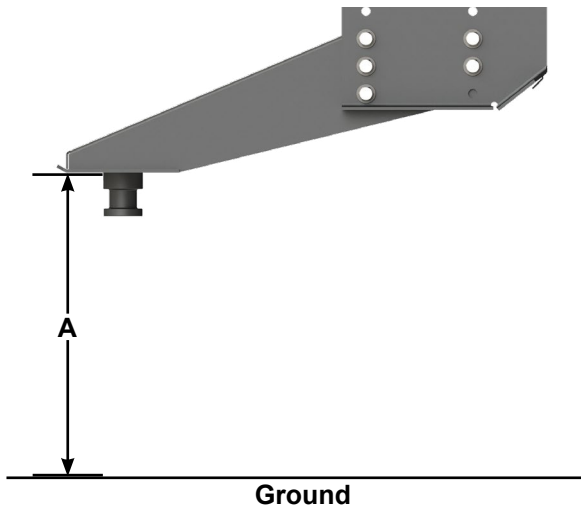

⚠ WARNING

AN UNSUPPORTED PIN BOX DURING PRODUCT REMOVAL CAN RESULT IN DEATH, SERIOUS PERSONAL INJURY, SEVERE PRODUCT AND/OR PROPERTY DAMAGE. PROPERLY SUPPORT PIN BOX BEFORE REMOVING MOUNTING BOLTS.

3. Properly support the pin box assembly.
4. Remove fasteners holding the original pin box in place.
5. Remove original pin box. Retain mounting fasteners for reuse.
6. Hoist the new pin box into place.
7. When installing the new pin box, measure from the ground up to the flat plate of the upper jaw of the pin box. Once the new pin box is aligned, that measurement should be equal to the measurement taken in step 2 plus 11 3/4". Record this dimension as B (Fig.2).
8. Reinstall previously removed fasteners (step 4).

NOTE: Use the same amount of fasteners as were previously used. If any nuts, bolts or washers are damaged or unusable, replace with new fasteners equivalent in style, grade and diameter as original hardware.

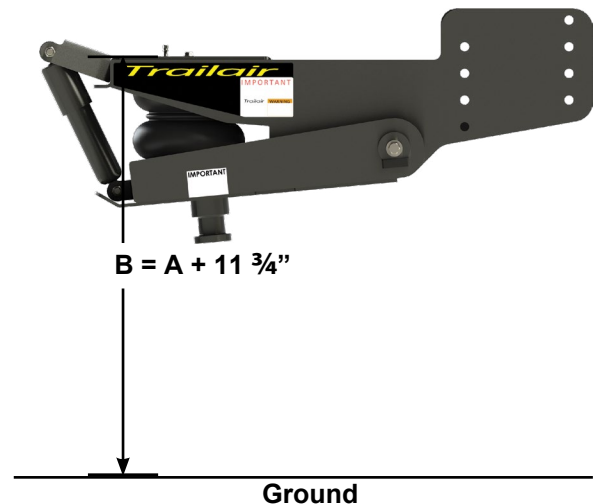



Air Ride™ Pin Box Installation and Owner's Manual (For Aftermarket Applications)

9. Torque pin box bolts and nuts accordingly:

- Torque ½” bolts to 110 ft-lbs minimum.
- Torque 5/8” bolts to 160 ft-lbs minimum.
- Torque ¾” bolts to 210 ft-lbs minimum.

10. Make sure that the 5th wheel coupler located in the tow vehicle is mounted according to the proper instructions of the 5th Wheel manufacturer. In addition, make sure that it is in good working condition. A non- or poor-working coupler will affect pin box performance, resulting in an unsafe towing condition. Make sure the 5th Wheel connection is never located behind the center of the drive axle.

11. After all nuts and bolts have been tightened, attach trailer to tow vehicle. Before applying the air nozzle fitting at the top of the pin box, make sure the alignment pin is in the hole on the bottom of the air spring.

12. With the tow vehicle at rest, inflate the air bag with enough air to raise the pin box to the ride height mark on the front of the shock absorber (Fig.3A). The starting pressure should be around 80-90 psi, with the pressure increased according to the ride height mark. However, the

pressure is not to exceed 120 psi. Filling should be stopped when reaching either the ride height mark or 120 psi, whichever comes first. The minimum pressure is 45 psi.

13. Check the air pressure level on the air bag before each use and adjust accordingly.

Operation

⚠ WARNING

AN OVERINFLATED AIR BAG CAN BURST, RESULTING IN DEATH, SERIOUS PERSONAL INJURY, SEVERE PRODUCT AND/OR PROPERTY DAMAGE. DO NOT OVERINFLATE AIR BAG. INFLATE AIR BAG TO RIDE HEIGHT LEVEL IDENTIFIED ON THE SHOCK ABSORBER.

⚠ CAUTION

THE AIR BAG CAN LOSE AIR OVER TIME, RESULTING IN REDUCED OR LOSS OF PRODUCT PERFORMANCE. REDUCED OR LOSS OF PRODUCT PERFORMANCE CAN CAUSE PRODUCT AND/OR PROPERTY DAMAGE. ALWAYS VERIFY CORRECT LEVEL AGAINST THE SHOCK'S HEIGHT MARK AND TRAILER BEFORE TRAVELING. ADJUST AIR PRESSURE AS NECESSARY TO ACHIEVE CORRECT PIN BOX LEVEL.

⚠ CAUTION

AN UNSECURED AIR SPRING DURING INFLATION CAN CAUSE PERSONAL INJURY. MAKE SURE AIR SPRING IS PROPERLY SECURED TO THE PIN BOX BEFORE INFLATING. INSTALL AIR CAP TO SAFELY COMPLETE AIR SPRING INFLATION.

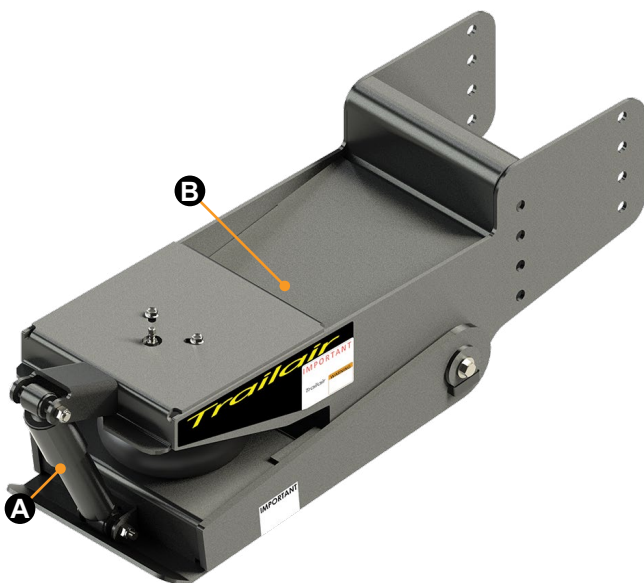

Fig.3

Pull Test

1. Make sure the trailer wheels are blocked, the trailer landing gear is resting on firm ground to support the trailer and the tow vehicle is in park with the emergency brake engaged.
2. Return to the cab of the tow vehicle, release the emergency brake and then apply the trailer brakes.



Air Ride™ Pin Box

Installation and Owner's Manual

(For Aftermarket Applications)

⚠ WARNING

FAILURE TO PERFORM A PULL TEST MAY RESULT IN SEVERE PROPERTY DAMAGE, SERIOUS PERSONAL INJURY OR DEATH. FAILURE TO SECURE TOW VEHICLE AND TRAILER FROM MOVEMENT DURING PROCEDURE COULD RESULT IN SEVERE PROPERTY DAMAGE, SERIOUS PERSONAL INJURY OR DEATH. MAKE SURE TOW VEHICLE AND TRAILER ARE PROPERLY SECURED AGAINST MOVEMENT DURING THE PROCEDURE.

3. Slowly pull the trailer forward with the tow vehicle.
 - A. If the tow vehicle is properly hitched, the wheel blocks and trailer brakes should keep the truck from moving forward.
 - B. If the trailer is not properly hitched, the trailer will separate from the hitch and the truck will move forward while leaving the trailer behind. If this happens, repeat hitching procedure.
4. After successfully performing the pull test, fully raise the landing gear per manufacturer's recommendations.
5. Check and inspect all electrical circuits for proper operation, to include clearance lights, turn signals and stop lights.
6. Remove and store all trailer wheel blocks.

Troubleshooting

What is happening?	What should be done?
Trailer not level.	Adjust pin box or hitch accordingly.
Excessive chucking in tow vehicle.	Inspect pin box air bag air pressure. Add or remove air to recommended point. If low, check for leaks and replace if needed.
Excessive noise from pin box area.	Verify that the pin box is securely attached to the 5th wheel. If the king pin is excessively worn, the jaw plate will need to be replaced. Check pressure in air bag and replace if not holding air. Look for damage on shock or a disconnected shock. Reconnect or replace shock if needed. Hitch mechanisms can also cause noise. Verify that unwanted noise is not coming from the hitch. The hitch manufacturer can provide guidelines for this check.

