



72" Cultipacker

OWNER'S MANUAL



WARNING:

Read carefully and understand all **ASSEMBLY AND OPERATION INSTRUCTIONS** before operating. Failure to follow the safety rules and other basic safety precautions may result in serious personal injury.

MODEL # FTF-0632CPATV

Thank you very much for choosing this product! For future reference, please complete the owner's record below:

Model: FTF-0632CPATV Purchase Date: _____

Save the receipt, warranty, and these instructions. It is important that you read the entire manual to become familiar with this product before you begin using it.

This product is designed for certain applications only. The manufacturer cannot be responsible for issues arising from modification. We strongly recommend this product not be modified and/or used for any application other than that for which it was designed. If you have any questions relative to a particular application, DO NOT use the product until you have first contacted us to determine if it can, or should, be performed on the product.

For technical questions, please call **1-218-943-6296**.

TECHNICAL SPECIFICATIONS

| Item | Description |
|-------------------|---------------|
| Packer Wheel Qty. | 32 |
| Packer Wheel Size | 9.5" |
| Tongue Length | 36.75" |
| Hitch Pin | Included |
| Wheel Size | 13" pneumatic |

IMPORTANT SAFETY INFORMATION



WARNING: Read and understand all instructions. Failure to follow all instructions listed below may result in serious injury.



CAUTION: Do not allow persons to operate or assemble this cultipacker until they have read this manual and have developed a thorough understanding of how it works.



WARNING: The warnings, cautions, and instructions discussed in this instruction manual cannot cover all possible conditions or situations that could occur. It must be understood by the operator that common sense and caution are factors that cannot be built into this product, but must be supplied by the operator.



WARNING: Do not exceed 30 PSI in each wheel.

SAVE THESE INSTRUCTIONS

WORK AREA

- **Keep work area clean**, free of clutter, and well lit. Cluttered and dark work areas can cause accidents.
- **Keep children and bystanders** away while operating the cultipacker. Distractions can cause you to lose control, so visitors should remain at a safe distance from the work area.
- **Be alert of your surroundings.** Using a cultipacker in confined work areas may put you dangerously close to sharp tools and rotating parts.

PERSONAL SAFETY

- **Stay alert**, watch what you are doing, and use common sense when using a cultipacker. Do not use while you are tired or under the influence of drugs, alcohol, or medication. A moment of inattention while operating a cultipacker may result in serious personal injury.
- **Dress properly.** Do not wear loose clothing, dangling objects, or jewelry. Keep your hair, clothing, and gloves away from moving parts. Loose clothes, jewelry, or long hair can be caught in moving parts.
- **Use safety apparel and equipment.** Use safety goggles or safety glasses with side shields that comply with current national standards or, when needed, a fact shield. Use a dust mask if working in dusty work conditions. This applies to all persons in the work area. Also use non-skid, safety shoes, hardhat, gloves, dust collections systems, and hearing protecting when appropriate.
- **Do not have passengers** on the tow vehicle when pulling the cultipacker.
- **Do not turn too short when pulling the cultipacker.** Turning too short can result in the cultipacker catching a tire and possibly injuring the operator.

CULTIPACKER USE AND CARE

- **Do not modify the cultipacker in any way.** Unauthorized modification may impair the function and/or safety and could affect the life of the equipment. There are specific applications for which the cultipacker was designed.
- **Always check for damaged or worn-out parts before using the cultipacker.** Broken parts will affect cultipacker operation. Replace or repair damaged or worn parts immediately.
- **Store idle cultipacker.** When the cultipacker is not in use, store it in a secure place out of the reach of children. Inspect it for good working condition prior to storage and before re-use.
- **Transporting cultipacker** on hard road type surfaces can result in excessive packer wheel wear or possible packer wheel damage.
- **Care should be taken when flipping the cultipacker over for either use or transport.** Place one foot on the packer wheels and securely hold when flipping. Improper flipping can result in bodily injury and/or property damage.
- **There are two grease points on the cultipacker.** There is a bearing on each end of the packer wheel shaft. It is recommended that these bearings be greased at least every 4 hours. In dusty conditions more frequent greasing may be necessary.
- **For best results it may be necessary to pack the soil before seeding and then pack the soil a second time after seeding.** This is especially true with small seeds that require shallow seeding.

ASSEMBLY

Step #1:

Attach Tongue (12) to the Frame Bar (14) using four Bolts (11), four Washers (6), and four Nuts (5).

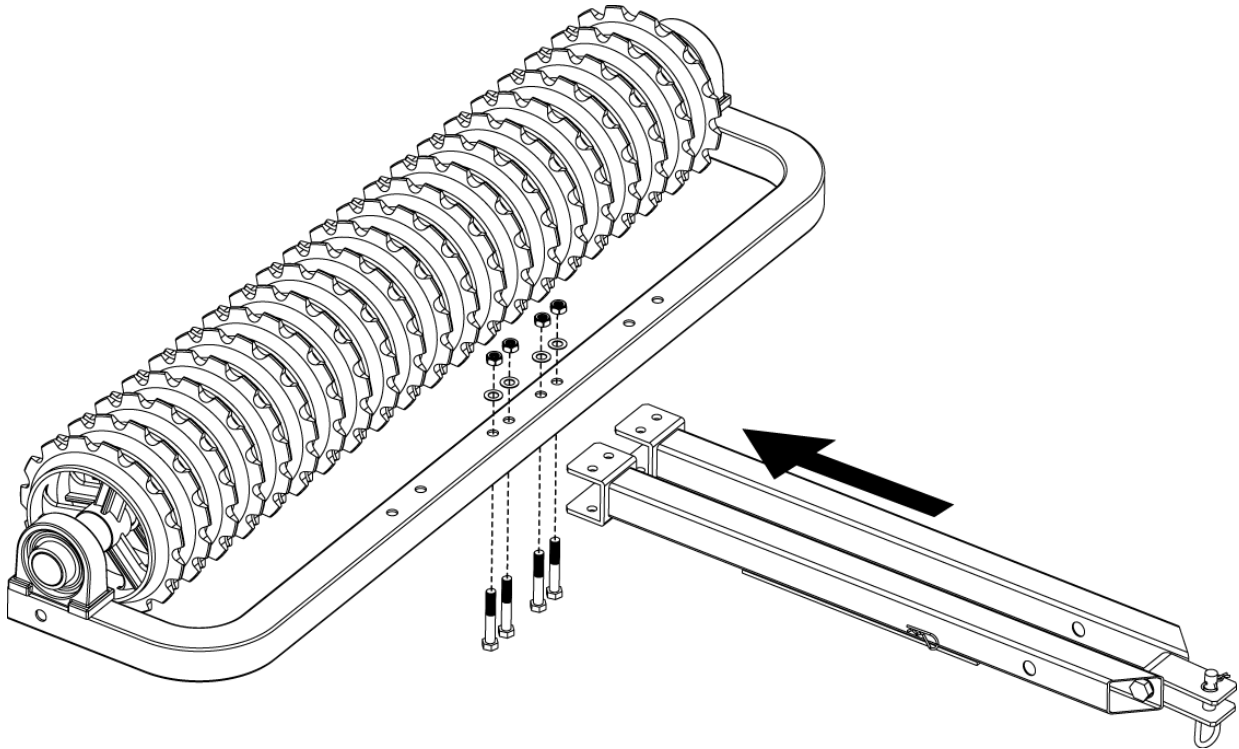

Step #2:

Attach each Wheel (18) to the Frame Bar (14) using two Bolts (19), six Washers (3), two Axle Bushings (15), and two Nuts (4). Do not over tighten the two nuts, to ensure the wheel turns freely. The Packer assembly is not shown for image clarity.

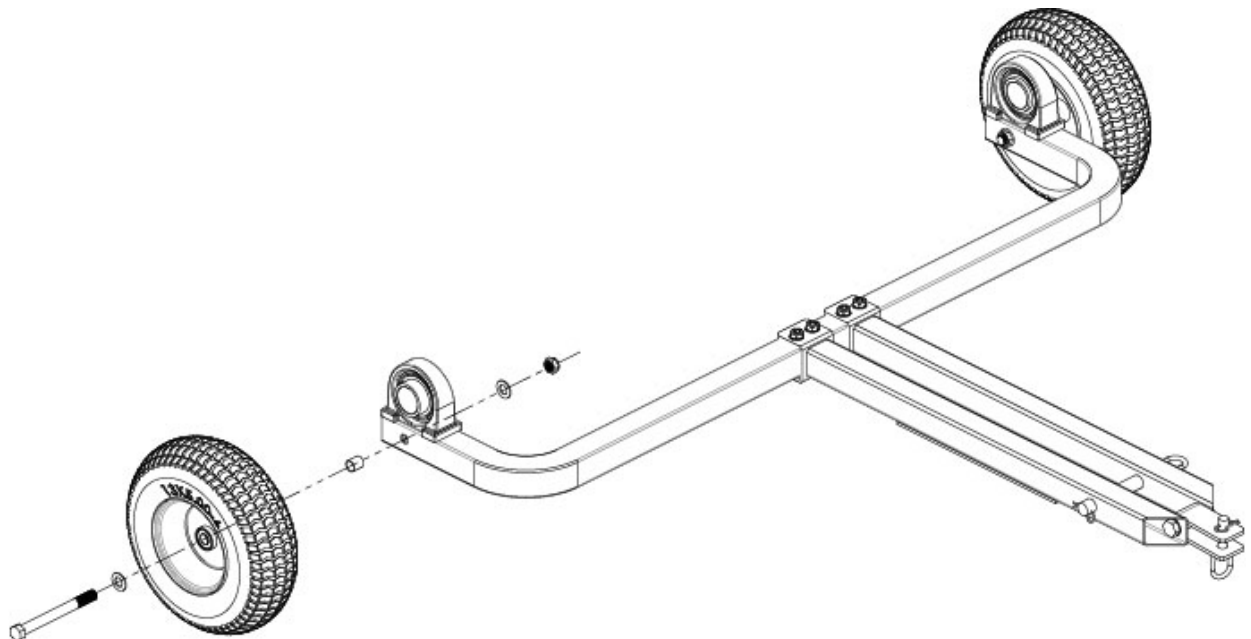

OPERATION

The Cultipacker can be used with an ATV, UTV, or utility tractor. The operation position is when the cast iron packer wheels are lower than the transport wheels. This allows the cultipacker to pulverize soil clumps and create moisture retaining dimples.

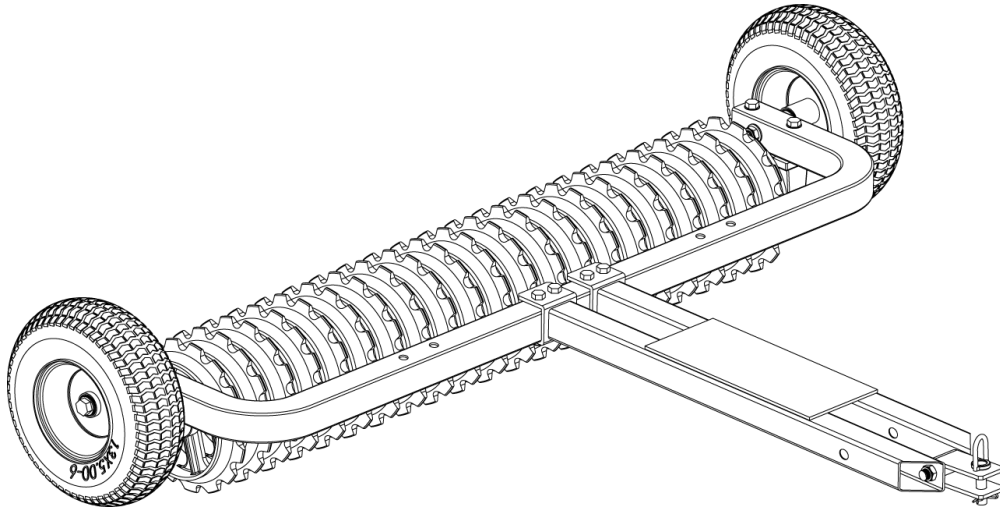

TRANSPORTATION

To put the Cultipacker in transport mode, simply flip the tongue over the unit. This will raise it off the ground and allow for transportation.

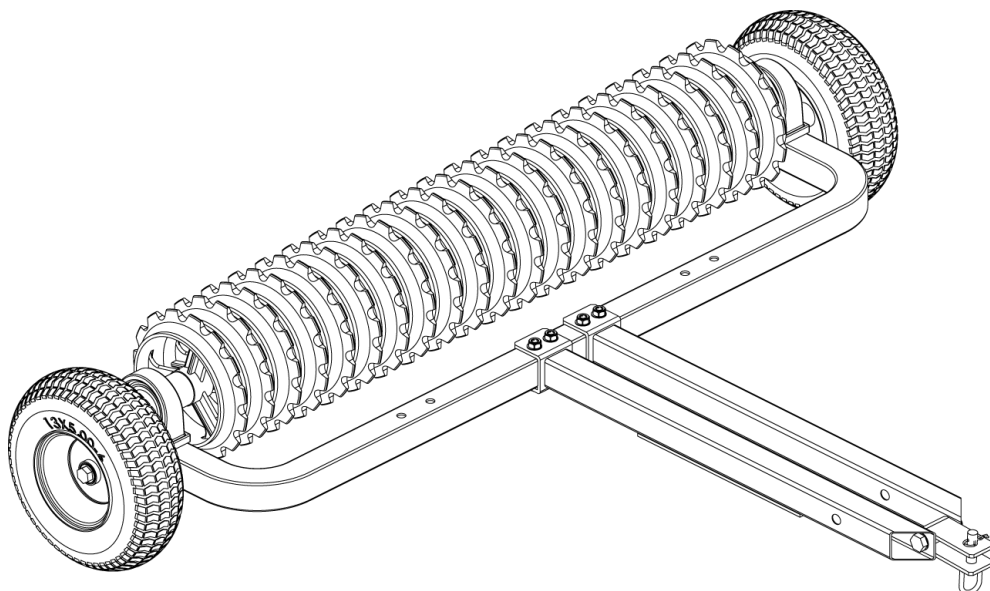

CAST IRON PACKER DISK REPLACEMENT

Release the small bolt in the bearing coupler, then the shaft can be removed from the bearing coupler and the wheels taken off. Replace damaged packer disks as needed. Reference image below.

PARTS LIST:

| Part # | Description | Qty. | Part # | Description | Qty |
|--------|------------------|------|--------|------------------|-----|
| 1 | Main Disc Axle | 1 | 12 | Tongue | 1 |
| 2 | Cast Iron Packer | 21 | 13 | Bolt, M14 x 8cm | 4 |
| 3 | Washer, M20 | 2 | 14 | Frame Bar | 1 |
| 4 | Nut, M20 | 2 | 15 | Coupler Bushing | 2 |
| 5 | Nut, M14 | 4 | 16 | Coupler Bearing | 2 |
| 6 | Washer, M14 | 8 | 17 | Axle Bushing | 2 |
| 7 | Nut, M16 | 1 | 18 | Wheel | 2 |
| 8 | U-Bracket | 1 | 19 | Washer, M25 | 2 |
| 9 | Hitch Pin | 1 | 20 | Bolt, M24 x 18cm | 2 |
| 10 | Washer, M16 | 3 | 21 | Bolt, M14 x 7cm | 4 |
| 11 | Bolt, M16 x 10cm | 1 | | | |

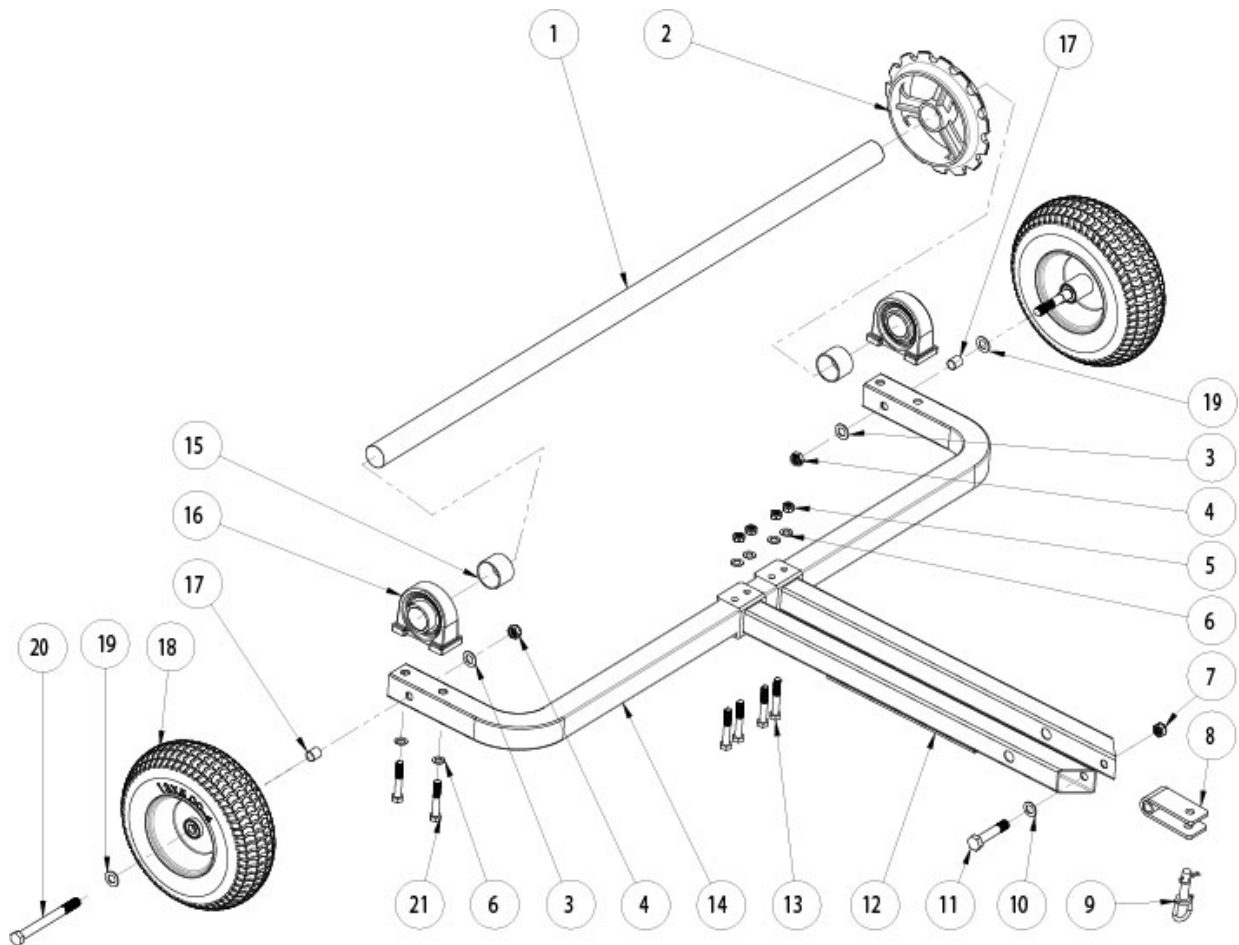

MAINTENANCE

- **Maintain your cultipacker.** It is recommended that the general condition of any cultipacker be examined before it is used. Keep your cultipacker in good repair by adopting a program of conscientious repair and maintenance. If any abnormal vibrations or noise occurs, have the problem corrected before further use. Have necessary repairs made by qualified service personnel.
- **Do not exceed 30 PSI in each wheel.**

For technical questions, please call **1-218-943-6296**.

WARRANTY

One-year limited parts warranty.



TG
PO BOX 203
Miltona, MN 56354
Made in China