

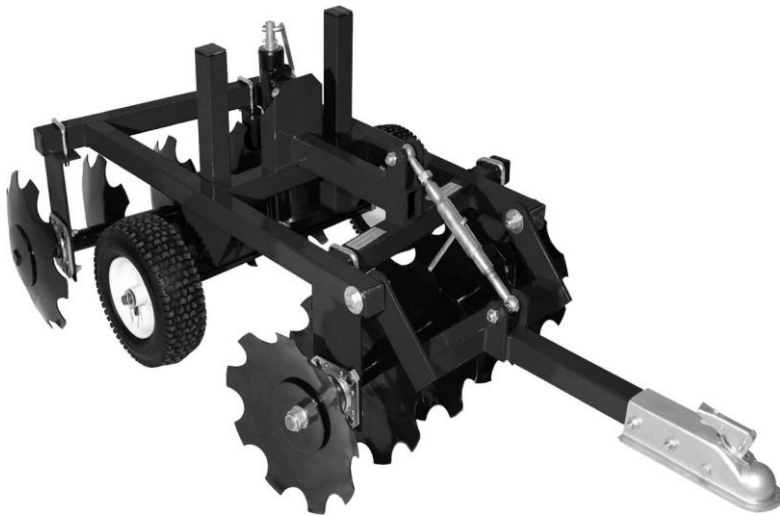

ATV Disc

OWNER'S MANUAL



WARNING:

Read carefully and understand all **ASSEMBLY AND OPERATION INSTRUCTIONS** before operating. Failure to follow the safety rules and other basic safety precautions may result in serious personal injury.

Item# ATV-DH

03082016

Thank you very much for choosing this product! For future reference, please complete the owner's record below:

Model: ___ATV-DH_____ Purchase Date: _____

Save the receipt, warranty and these instructions. It is important that you read the entire manual to become familiar with this product before you begin using it.

This machine is designed for certain applications only. The manufacturer cannot be responsible for issues arising from modification. We strongly recommend this machine not be modified and/or used for any application other than that for which it was designed. If you have any questions relative to a particular application, DO NOT use the machine until you have first contacted us to determine if it can or should be performed on the product.

For technical questions please call **1-218-943-6296**.

INTENDED USE

Disc cultivator that is great for deep woods, wildlife food plots, small gardens, row cultivation and yard prep work.

TECHNICAL SPECIFICATIONS

2" Ball Hitch, Tire Size: 12" -5.00-6
Ten -14" Diameter Notched Disc Blades are removable and replaceable.
2" x 2" Heavy weight steel tube design- 1/8" thick
Easily pull by 4-wheelers, garden tractors and sub-compact tractors
33" Cutting Width, 4" Cutting Depth
1" Square disc axle

GENERAL SAFETY RULES



WARNING: Read and understand all instructions. Failure to follow all instructions listed below may result in serious injury.



CAUTION: Do not allow persons to operate or assemble this disc until they have read this manual and have developed a thorough understanding of how the disc works.



WARNING: The warnings, cautions, and instructions discussed in this instruction manual cannot cover all possible conditions or situations that could occur. It must be understood by the operator that common sense and caution are factors which cannot be built into this product, but must be supplied by the operator.

SAVE THESE INSTRUCTIONS

WORK AREA

- **Keep work area clean**, free of clutter and well lit. Cluttered and dark work areas can cause accidents.
- **Keep children and bystanders** away while operating a disc. Distractions can cause you to lose control, so visitors should remain at a safe distance from the work area.
- **Be aware of all power lines, electrical circuits**, water pipes and other mechanical hazards in your work area, particularly those hazards below the work surface hidden from the operator's view that may be unintentionally contacted and may cause personal harm or property damage.
- **Be alert of your surroundings**. Using a disc in confined work areas may put you dangerously close to cutting tools and rotating parts.

PERSONAL SAFETY

- **Stay alert**, watch what you are doing and use common sense when using a disc. Do not use a disc while you are tired or under the influence of drugs, alcohol or medication. A moment of inattention while operating a disc may result in serious personal injury.
- **Dress properly**. Do not wear loose clothing, dangling objects, or jewelry. Keep your hair, clothing and gloves away from moving parts. Loose clothes, jewelry or long hair can be caught in moving parts.
- **Use safety apparel and equipment**. Use safety goggles or safety glasses with side shields which comply with current national standards, or when needed, a face shield. Use a dust mask in dusty work conditions. This applies to all persons in the work area. Also use non-skid safety shoes, hardhat, gloves, dust collection systems, and hearing protection when appropriate.

DISC USE AND CARE

- **Do not modify the disc in any way**. Unauthorized modification may impair the function and/or safety and could affect the life of the equipment. There are specific applications for which the disc was designed.
- **Always check for damaged or worn out parts before using the disc**. Broken parts will affect the disc operation. Replace or repair damaged or worn parts immediately.
- **Do not exceed the disc load capacity**.
- **Distribute the load evenly**. Uneven loads may cause the disc to tip, resulting in personal injury to the operator or others.
- **Use the disc on flat and level surfaces** capable of supporting the disc and its maximum load. Pulling or pushing a load on a slanted or uneven surface can result in loss of control.
- **Store idle disc**. When disc is not in use, store it in a secure place out of the reach of children. Inspect it for good working condition prior to storage and before re-use.

ASSEMBLY

Step 1: Assemble the two disc gang assemblies as shown in diagram.

Note: The diagram shows each item number as it is assembled onto the Square Axle Weldment. Tighten Lock Nut so all discs are tight on Square Axle Weldment.

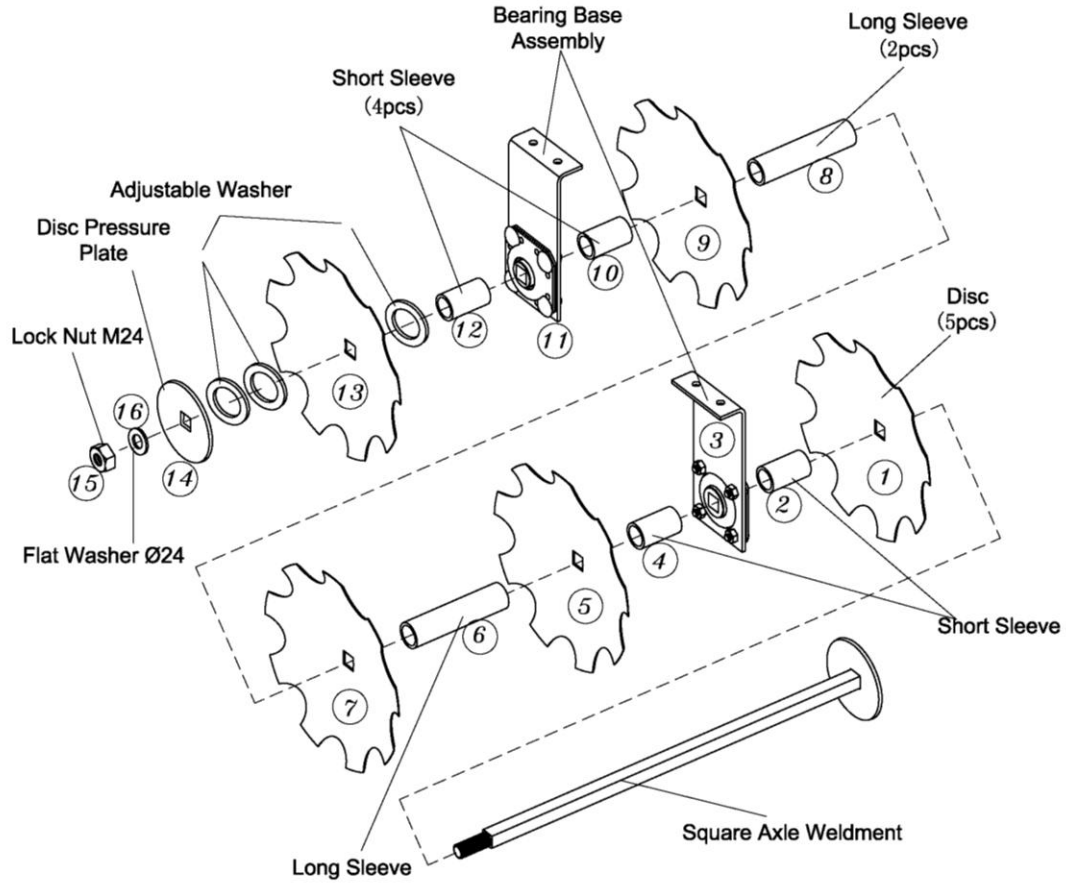

Tighten the lock nut

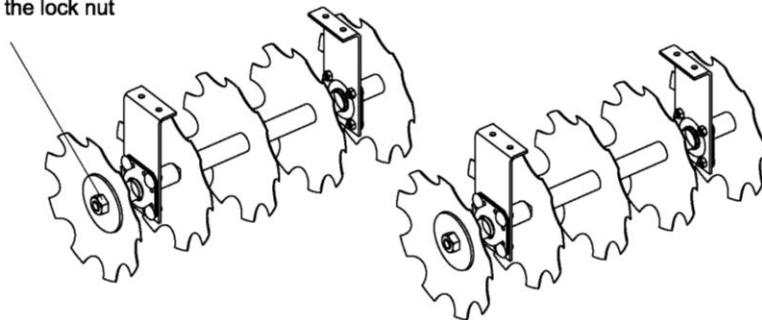

Step 2: Assemble the Hitch Tongue to the Frame using the Hex Bolts, Big Flat Washers and Lock Nuts. Note: Do not over tighten Hex Bolts and Lock Nuts, the Hitch Tongue should rotate up and down freely. Install the Wheel Bracket into the frame as shown in diagram. Note: Check the direction of angle iron on the wheel bracket as shown in diagram.

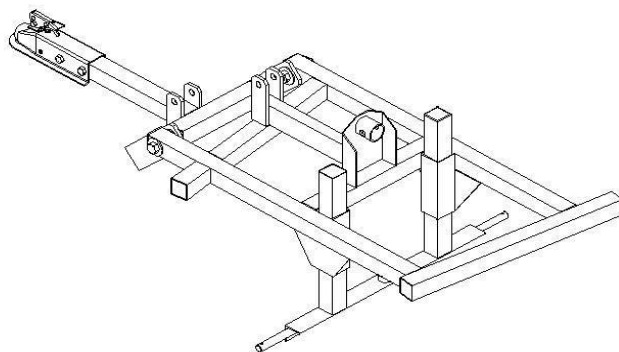
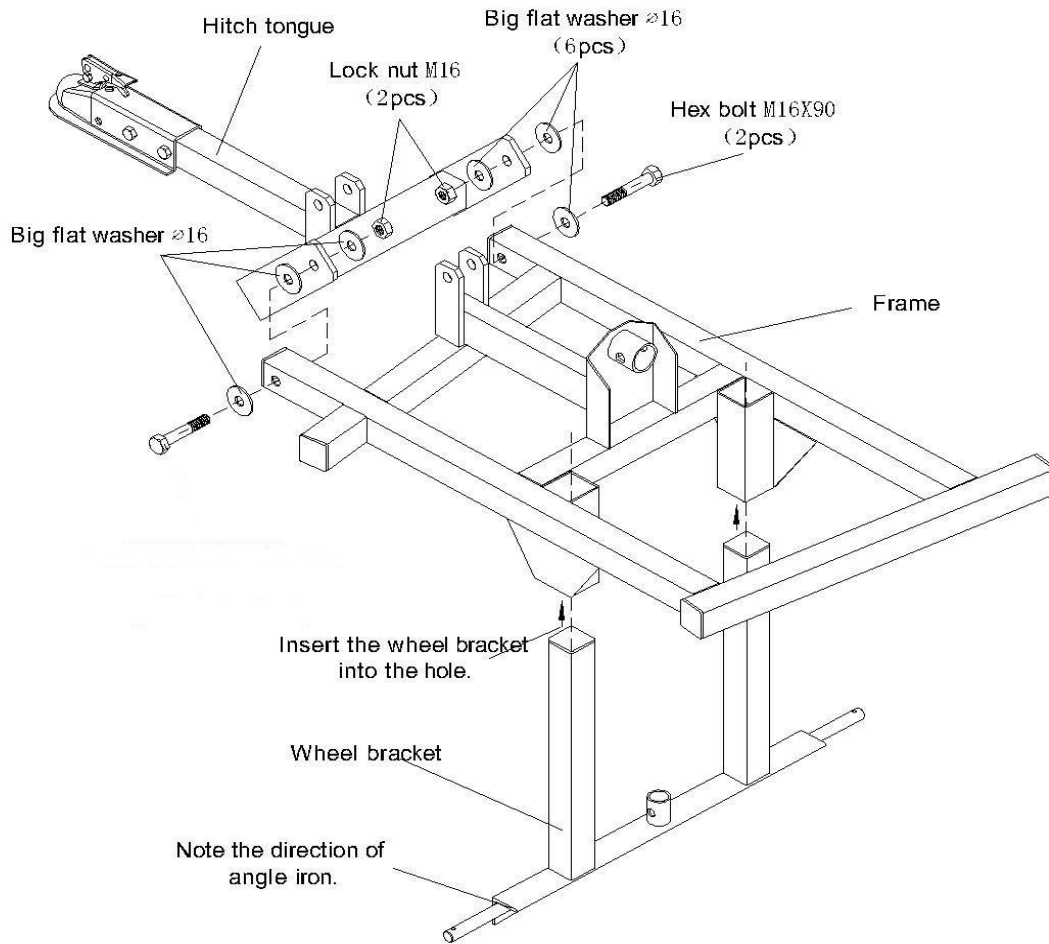

Step 3: Install the two Disc Gang assemblies to the frame using the U bolts and Lock Nuts as shown in diagram.

Note: Install the two Disc Gang assemblies in the opposite direction, if they are installed incorrectly the disc will not function properly.

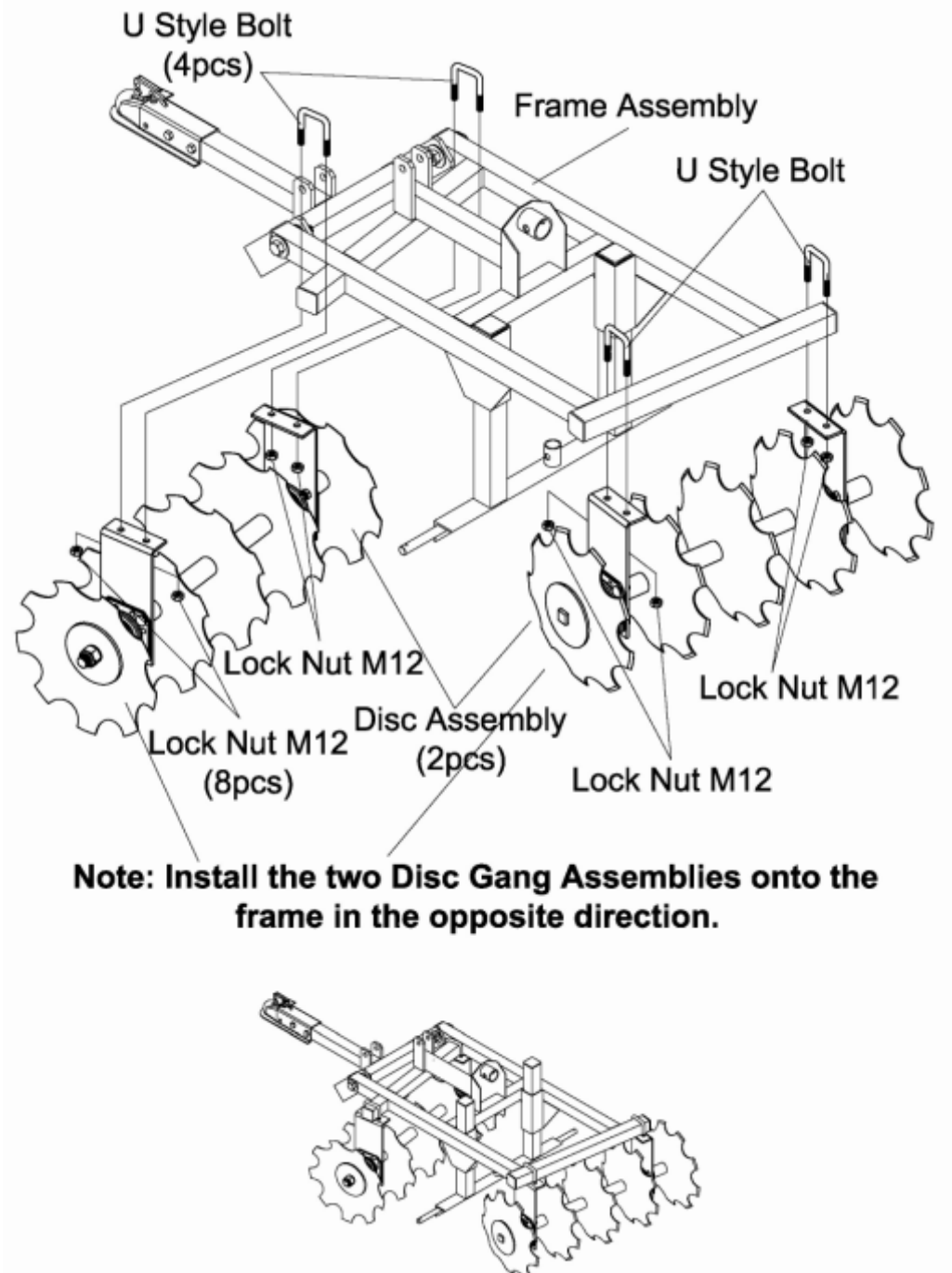

Step 4: Install the Mechanical Screw Jack onto the frame as shown in the diagram using the Hex bolts and Lock Nuts.

Note: Do not over tighten these two bolts and Lock Nuts.

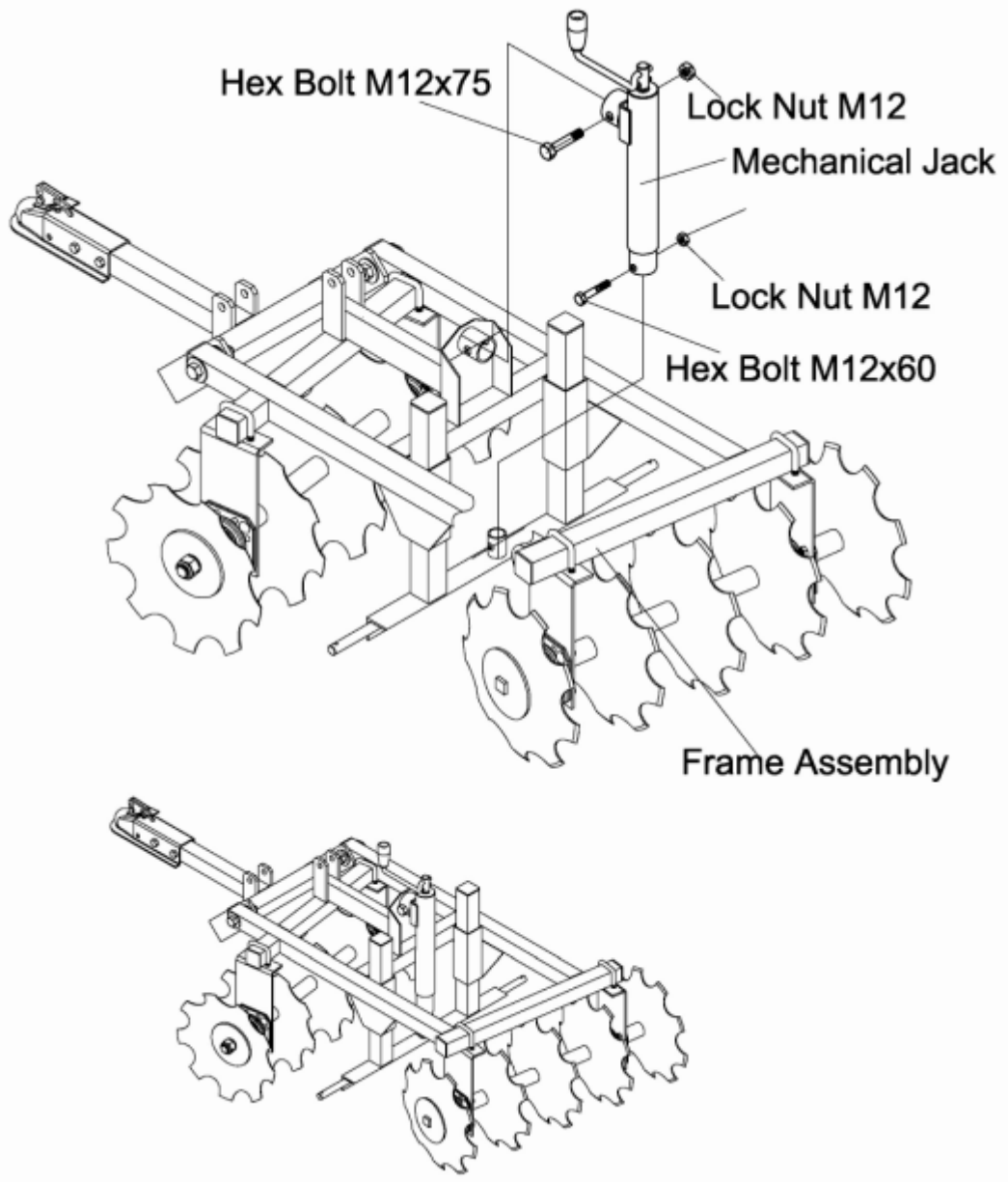

**Step 5: Install Adjustable Rod to the Hitch Tongue and the Frame using the Hex Bolts and Lock Nuts as Shown.
Install the Tires onto the Wheel bracket using the Flat Washers, Hex Bolts and Lock Nuts as shown.**

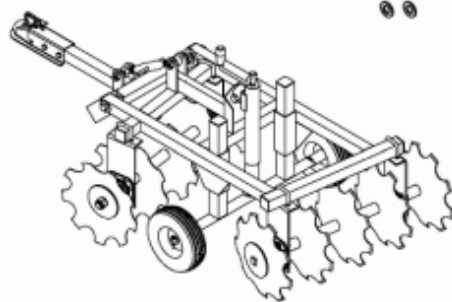
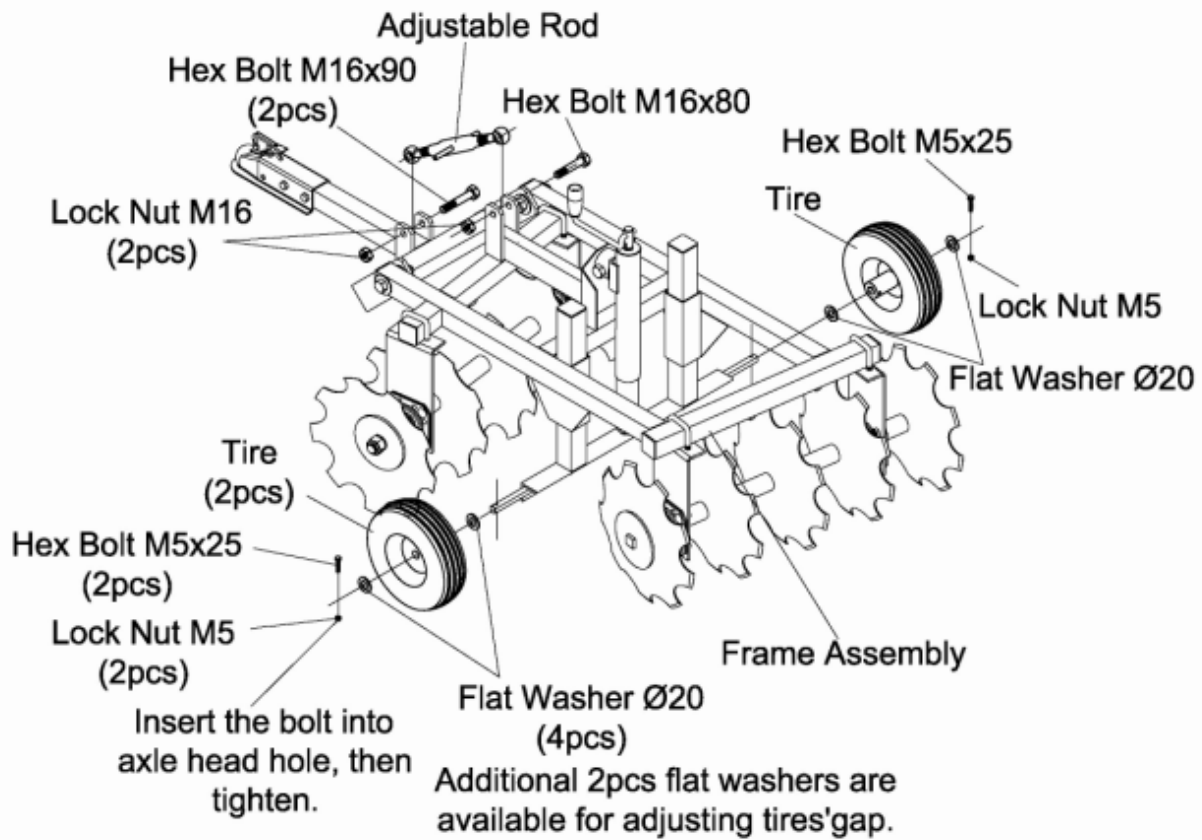

Step 6: There maybe some adjusting of the Hitch Tongue for the height of towing vehicle, this function can be performed by rotating handle on Adjusting Rod. Rotating the handle on the Mechanical Screw Jack will raise the tires up down.

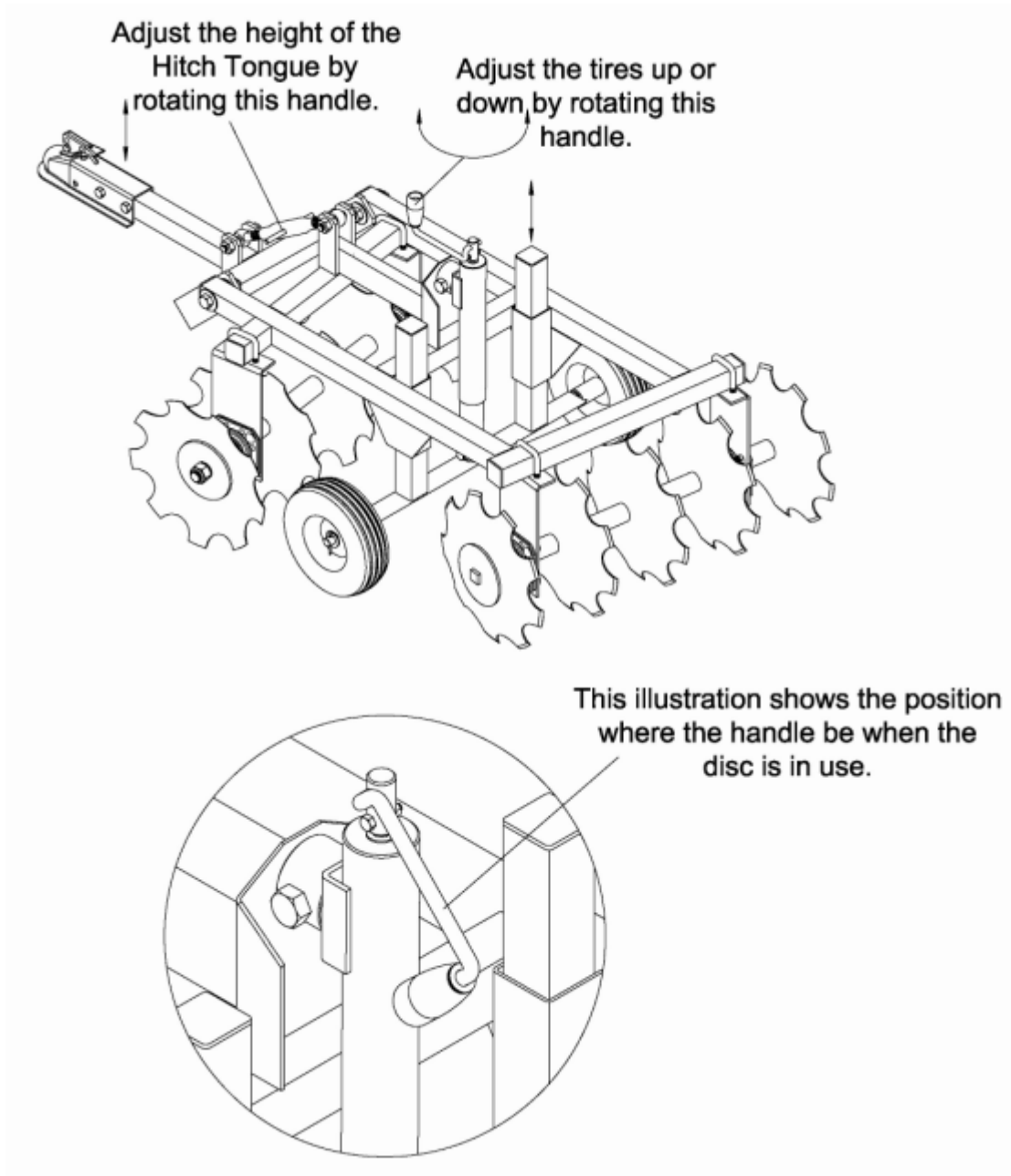

MAINTENANCE

- **Maintain your disc.** It is recommended that the general condition of any disc be examined before it is used. Keep your disc in good repair by adopting a program of conscientious repair and maintenance. If any abnormal vibrations or noise occurs, have the problem corrected before further use. Have necessary repairs made by qualified service personnel.

DIAGRAM & PARTS LIST

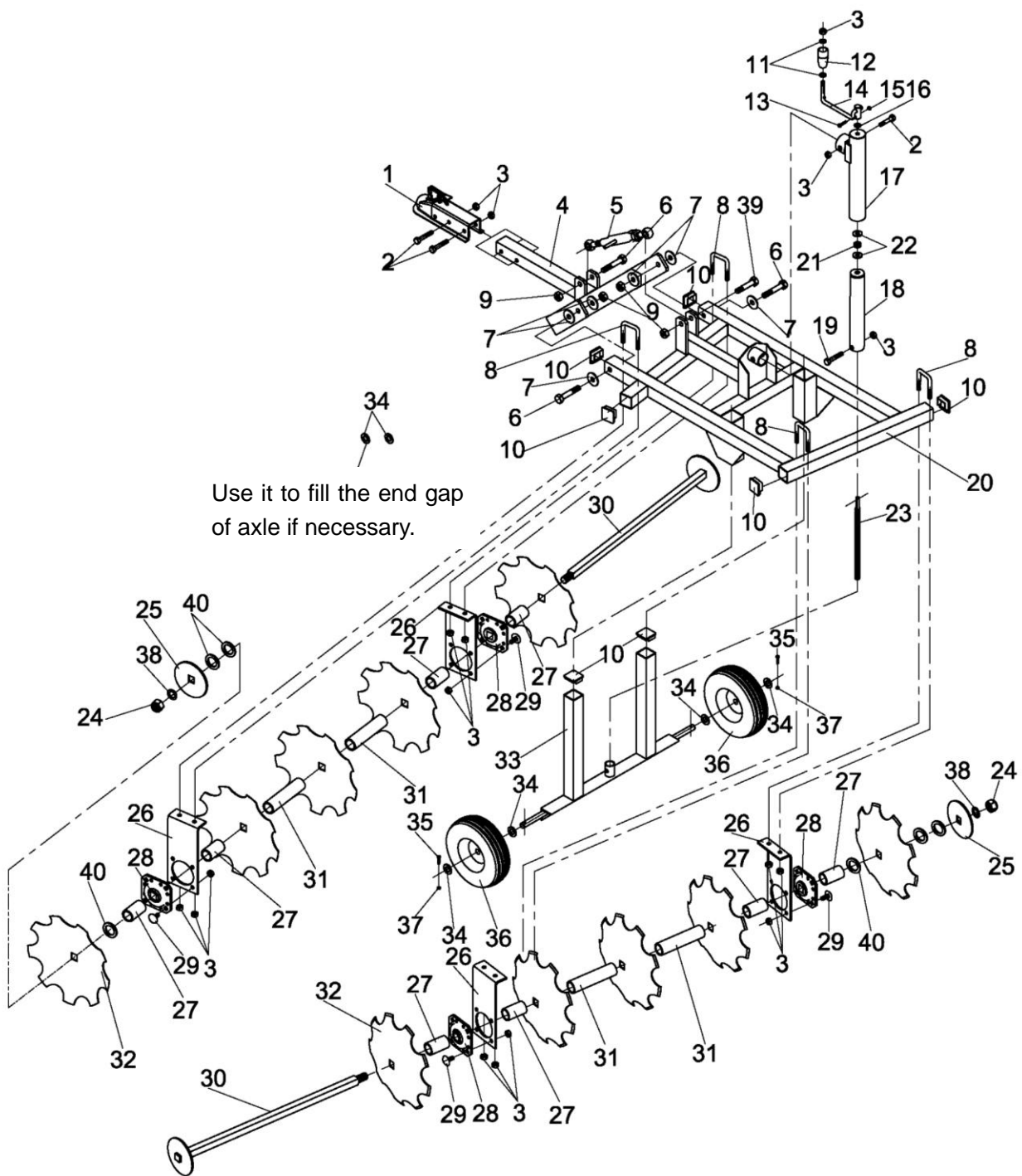

PART #	DESCRIPTION	QTY	PART #	DESCRIPTION	QTY
1	2" Coupling	1	21	Bearing	1
2	Hex Bolt M12x75	3	22	Thick Flat Washer Ø12	2
3	Hex Lock Nut M12	29	23	Threaded Rod	1
4	Hitch Tongue	1	24	Nylon Lock Nut M24	2
5	Adjustable Rod	1	25	Disc Pressure Plate	2
6	Hex Bolt M16x90	3	26	Disc Support Plate	4
7	Big Flat Washer Ø16	6	27	Short Sleeve	8
8	U Style Bolt	4	28	Bearing Base Assembly	4
9	Nylon Lock Nut M16	4	29	Carriage Bolt M12x30	16
10	End Cap	7	30	Square Axle Weldment	2
11	Flat Washer Ø12	2	31	Long Sleeve	4
12	Handle Grip	1	32	Disc	10
13	Hex Bolt M6x30	1	33	Wheel Bracket	1
14	Handle	1	34	Flat Washer Ø20	6
15	Nylon Nut M6	1	35	Hex Bolt M5x25	2
16	Big Flat Washer Ø12	1	36	Tire	2
17	Outside Sleeve	1	37	Nylon Lock Nut M5	2
18	Inside Sleeve	1	38	Flat Washer Ø24	2
19	Hex Bolt M12x60	1	39	Hex Bolt M16x80	1
20	Frame	1	40	Adjustable Washer Ø36	6

For replacement parts and technical questions, please call **1-218-943-6296**.

WARRANTY

One-year limited warranty



TG

PO Box 203

Milona, MN 56354

Made in CHINA