

48" Wide Landscape Rake

OWNER'S MANUAL



WARNING:

Carefully read and understand all **ASSEMBLY AND OPERATION INSTRUCTIONS** before operating. Failure to follow the safety rules and other basic safety precautions may result in serious personal injury.

MODEL # YTF-48LSR

Thank you very much for choosing this product! For future reference, please complete the owner's record below:

Model: YTF-48LSR Purchase Date: _____

Save the receipt, the warranty, and these instructions. It is important that you read the entire manual to become familiar with this product before you begin using it.

This product is designed for certain applications only. The manufacturer cannot be responsible for issues arising from modification. We strongly recommend that this product not be modified and/or used for any application other than that for which it was designed. If you have any questions relative to a particular application, DO NOT use the product until you have first contacted us to determine if it can, or should, be performed on the product.

For technical questions, please call **1-218-943-6296**.

TECHNICAL SPECIFICATIONS

Item	Description
Coverage	48" working width
Tine Qty.	24
Tires	12" pneumatic wheels
Nylon Rope Length	9.85'

IMPORTANT SAFETY INFORMATION



WARNING: Read and understand all instructions. Failure to follow all instructions listed below may result in serious injury.



CAUTION: Do not allow persons to operate or assemble this Landscape Rake until they have read this manual and have developed a thorough understanding of how it works.



WARNING: The warnings, cautions, and instructions discussed in this instruction manual cannot cover all possible conditions or situations that could occur. It must be understood by the operator that common sense and caution are factors that cannot be built into this product, but must be supplied by the operator.



WARNING: Do not exceed 30 PSI in each wheel.

SAVE THESE INSTRUCTIONS

WORK AREA

- **Keep work area clean**, free of clutter, and well-lit. Cluttered and dark work areas can cause accidents.
- **Keep children and bystanders** away while operating the landscape rake. Distractions can cause you to lose control, so visitors should remain at a safe distance from the work area.
- **Be alert of your surroundings.** Using a landscape rake in confined work areas may put you dangerously close to sharp tools and rotating parts.

PERSONAL SAFETY

- **Stay alert**, watch what you are doing, and use common sense when using a landscape rake. Do not use while you are tired or under the influence of drugs, alcohol, or medication. A moment of inattention while operating a landscape rake may result in serious personal injury.
- **Dress properly.** Do not wear loose clothing, dangling objects, or jewelry. Keep your hair, clothing, and gloves away from moving parts. Loose clothes, jewelry, or long hair can be caught in moving parts.
- **Use safety apparel and equipment.** Use safety goggles or safety glasses with side shields that comply with current national standards or, when needed, a face shield. Use a dust mask if working in dusty work conditions. This applies to all persons in the work area. Also use non-skid, safety shoes, hard hat, gloves, dust collections systems, and hearing protecting when appropriate.
- **Do not have passengers** on the tow vehicle when pulling the Landscape Rake.
- **Do not turn too short when pulling the Landscape Rake.** Turning too short can result in the Landscape Rake catching a tire and possibly injuring the operator.

LANDSCAPE RAKE USE AND CARE

- **Do not modify the Landscape Rake in any way.** Unauthorized modification may impair the function and/or safety and could affect the life of the equipment. There are specific applications for which the Landscape Rake was designed.
- **Always check for damaged or worn-out parts before using the Landscape Rake.** Broken parts will affect the Landscape Rake operation. Replace or repair damaged or worn parts immediately.
- **Store idle Landscape Rake.** When the Landscape Rake is not in use, store it in a secure place out of the reach of children. Inspect it for good working condition prior to storage and before re-use.
- **Exercise extreme caution when changing direction on slopes.** Do not operate across slopes. Use up and down only. Do not attempt to operate on steep slopes.
- **Beware of hidden, underground objects.** Contact with hidden objects might cause a sudden stop of the towing vehicle and damage to the Landscape Rake.
- **Do not operate the vehicle at speeds higher than 10 mph** and use care when backing up.
- **Do not load or unload the tow vehicle** with the Landscape Rake attached to the towing vehicle.

ASSEMBLY

Step #1:

Assemble the Height Adjustment Plate (#29) to the Axle Frame (#30), using three Hex Bolts (#15) and three Hex Lock Nuts (#3).

Step #2:

Attach the Pneumatic Tires (#31) to the Axle Frame (#30), using two Medium Washers (#32) and two Cotter pins (#33).

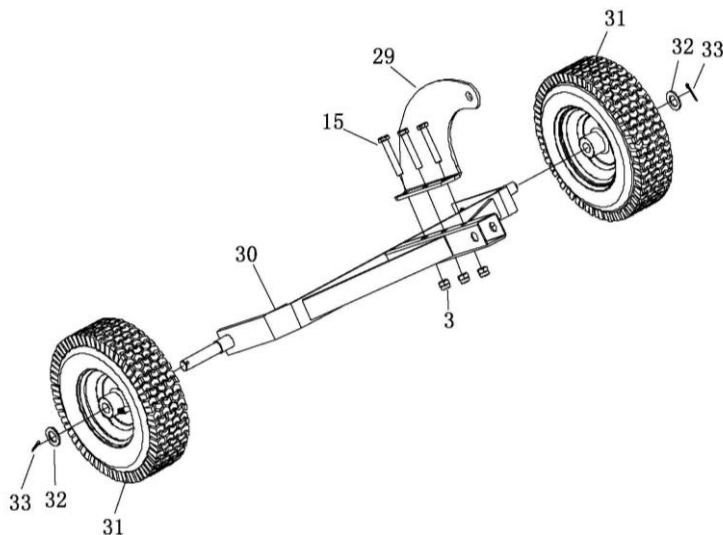

Step #3:

Connect the Tongue A (#1) and Tongue B (#4), using four Hex Bolts (#2) and four Hex Lock Nuts (#3).

Step #4:

Connect the Axle Frame (#30) and Tongue B (#4) using one Hex Bolt (#27) and one Hex Lock Nut (#28).

Step #5:

Attach the Lift Handle Support (#16) to the Tongue B (#4) using two Hex Bolts (#15) and two Hex Lock Nuts (#3).

Step #6:

Attach the Lift Handle (#20) to the Lift Handle Support (#16) using one Hex Bolt (#21) and one Hex Lock Nut (#22).

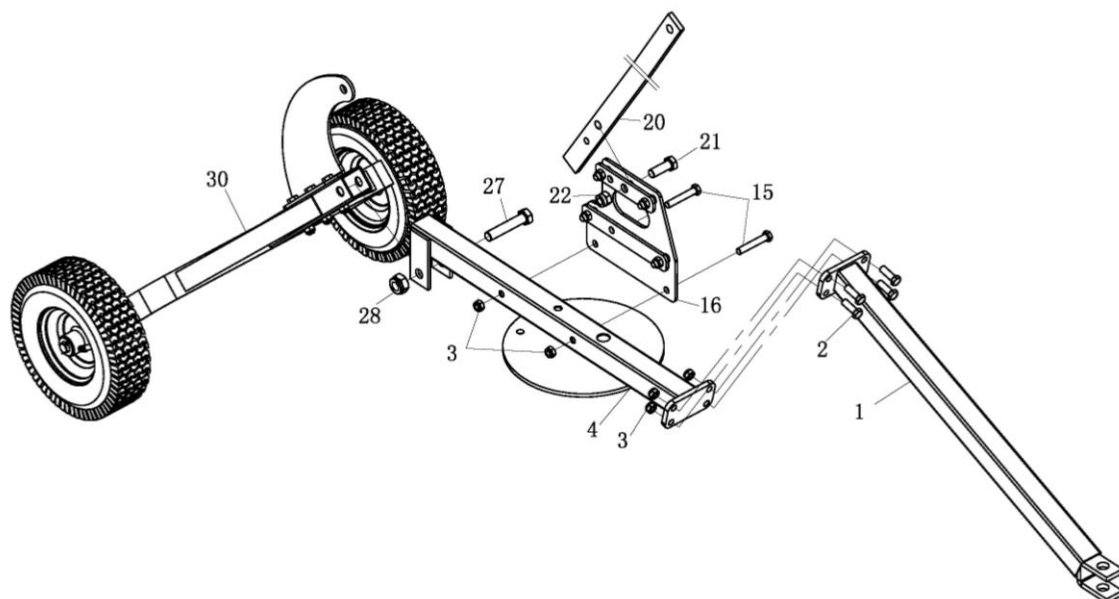

Step #7:

Attach one side of the Height Adjustment Component (#25) to the Lift Handle (#20), and attach the other side to the Height Adjustment Plate (#29) using two Hex Bolts (#23), two Bushings (#24), two Small Washers (#26), and two Hex Lock Nuts (#3).

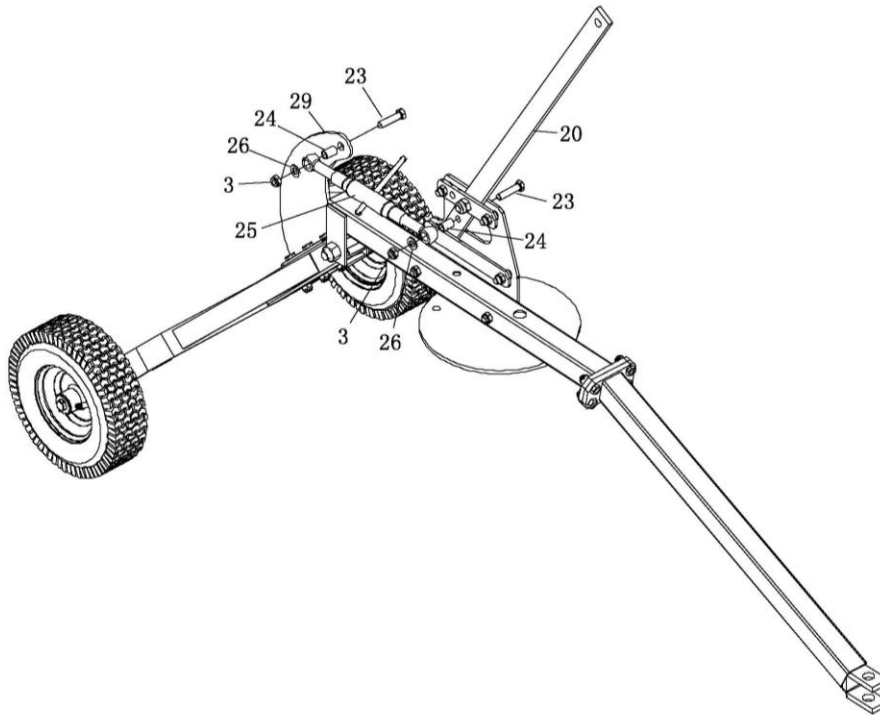

Step #8:

Attach the twenty-four Tines (#10) to the Tine Assembly Support (#9) and the four Tine Pressure Plates (#11) using twenty-four Hex Bolts (#8) and twenty-four Hex Lock Nuts (#12).

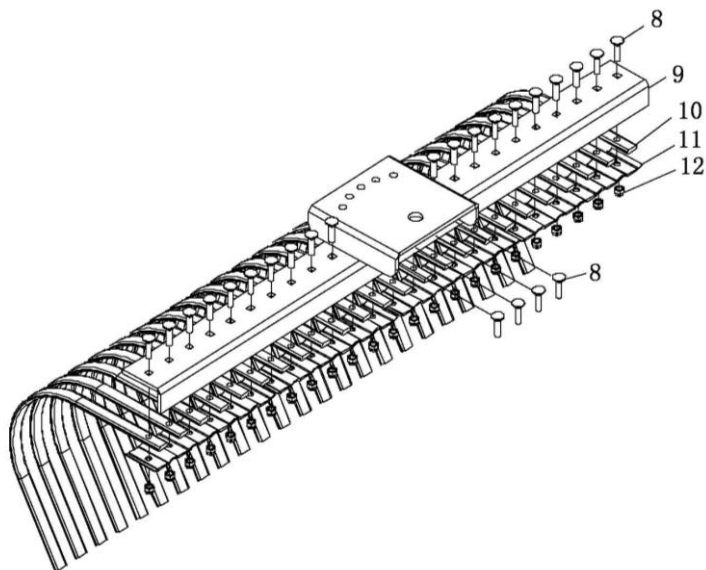

Step #9:

Connect the Tine Assembly to the Axle Assembly using one Hex Bolt (#5), two Large Washers (#6), and one Hex Lock Nut (#7).

Step #10:

Attach the Nylon Rope (#34) to the Lift Handle (#20).

Note: The Landscape Rake can be set at difference angles by removing the Hitch Pin (#13) and R Pin (#14), changing the angle, and then re-installing the Hitch Pin (#13) and the R Pin (#14).

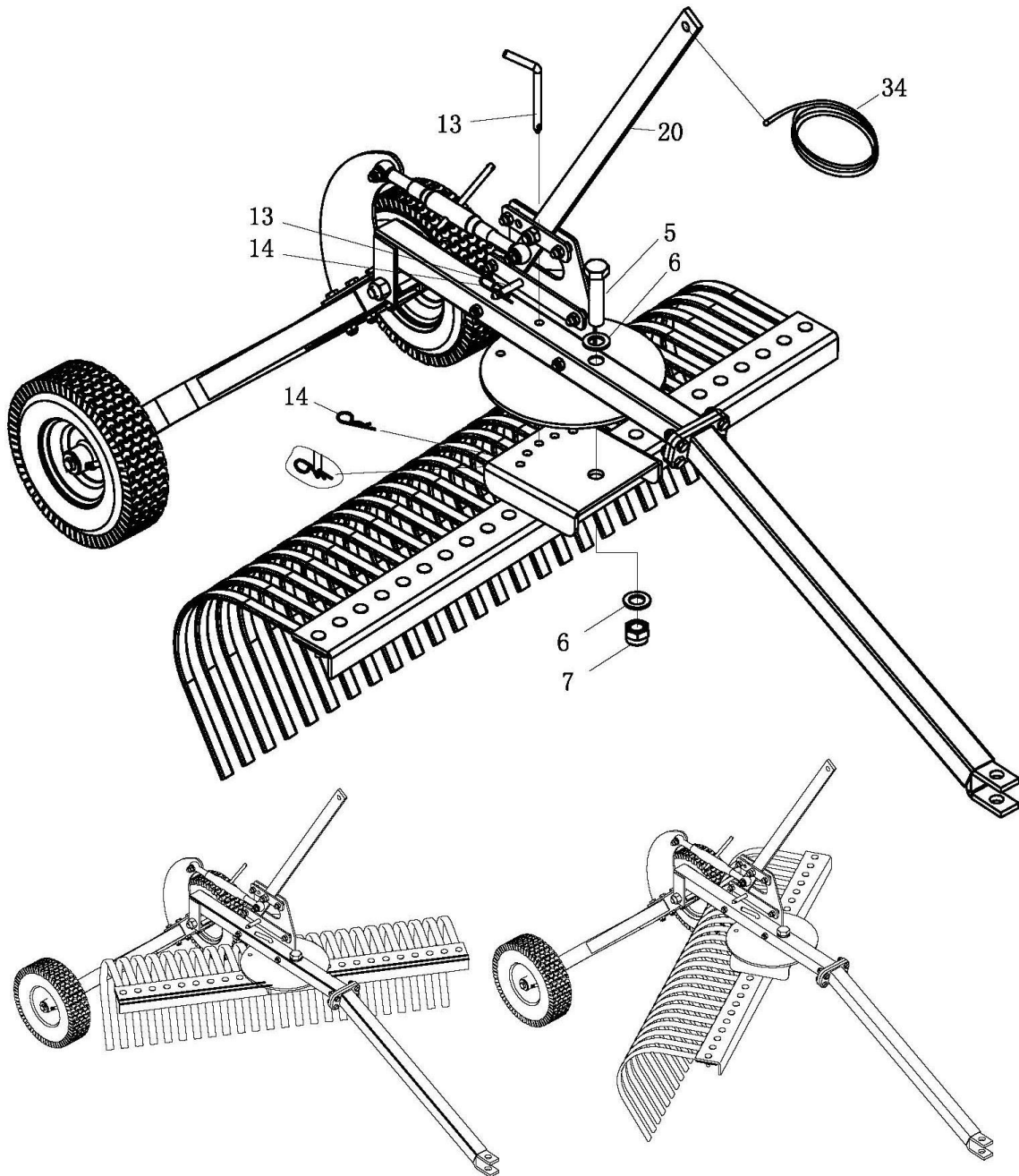

MAINTENANCE

- **Maintain your landscape rake.** It is recommended that the general condition of any landscape rake be examined before it is used. Keep your landscape rake in good repair by adopting a program of conscientious repair and maintenance. If any abnormal vibrations or noise occurs, have the problem corrected before further use. Have necessary repairs made by qualified service personnel.
- **Do not exceed 30 PSI in each wheel.**

PARTS DIAGRAM

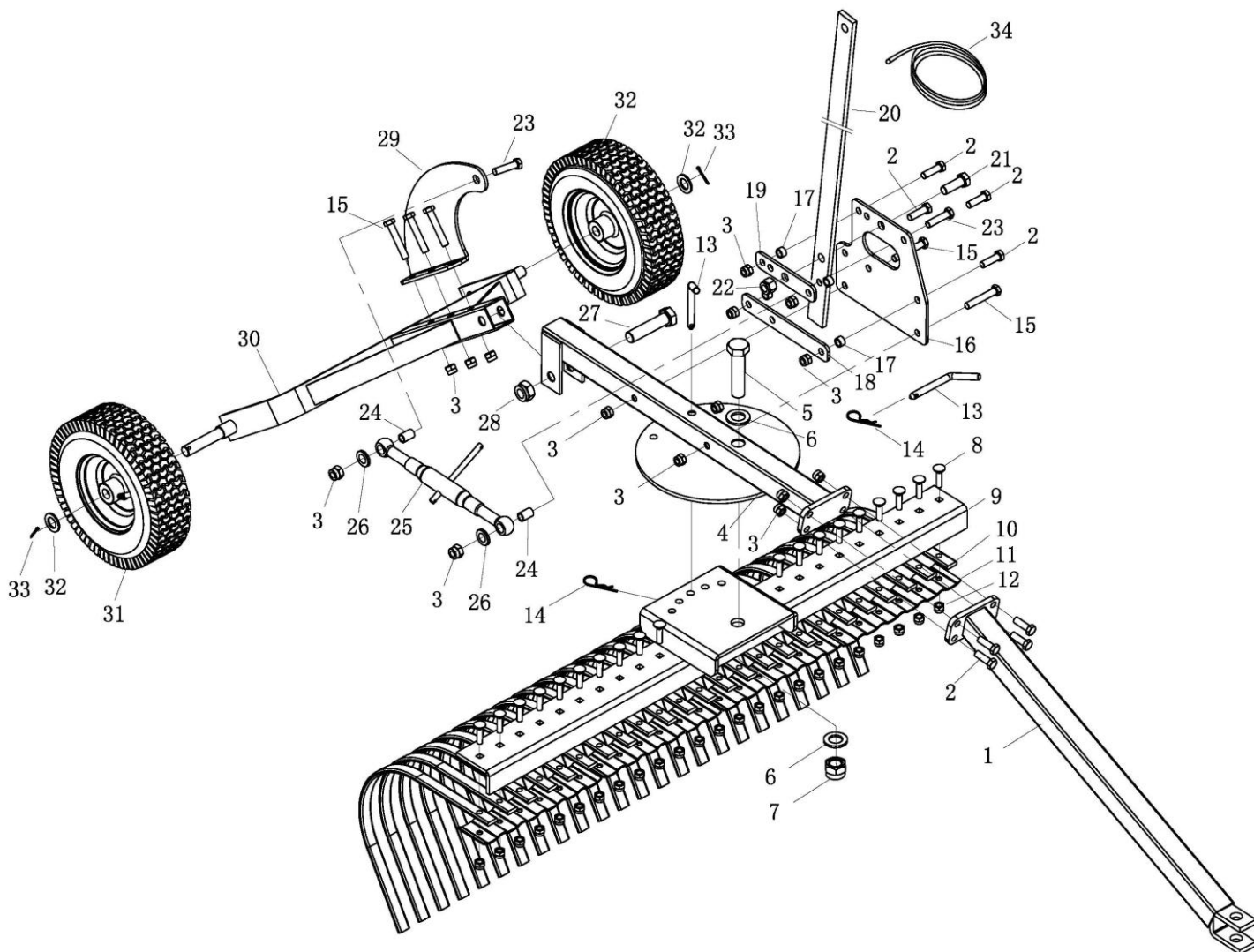

PARTS LIST:

Part #	Description	Qty.	Part #	Description	Qty.
1	Tongue A	1	18	Lift Handle Bracket #2	1
2	Hex Bolt M12*40	8	19	Lift Handle Bracket #1	1
3	Hex Lock Nut M12	15	20	Lift Handle	1
4	Tongue B	1	21	Hex Bolt M16*45	1
5	Hex Bolt M24*100	1	22	Hex Lock Nut M16	1
6	Large Washer Ø24	2	23	Hex Bolt M12*50	2
7	Hex Lock Nut M24	1	24	Bushing	2
8	Head Square neck bolt M10*30	24	25	Height Adjustment Component	1
9	Tine Assembly Support	1	26	Small Washer Ø12	2
10	Tine	24	27	Hex Bolt M18*90	1
11	Tine Pressure Plate	4	28	Hex Lock Nut M18	1
12	Hex Lock Nut M10	24	29	Height Adjustment Plate	1
13	Hitch Pin	2	30	Axle Frame	1
14	R Pin Ø2.5	2	31	12" Pneumatic Tire	2
15	Hex Bolt M12*70	5	32	Medium Washer Ø20	2
16	Lift Handle Support	1	33	Cotter Pin Ø4*50	2
17	Bushing Φ 17.5* Φ 12.5*11.2mm	4	34	Nylon Rope 9.85' x 8 mm	1

For technical questions, please call **1-218-943-6296**.

WARRANTY

One-year limited parts warranty.



TG
PO BOX 203
Miltona, MN 56354
Made in China