

LIMITED WARRANTY - TRANSFER PUMPS:

Decko Products warrants that the products specified in this warranty are free from defects in material or workmanship for one year from date of purchase. During the time period and subject to the terms and conditions, Decko Products will repair or replace to the original user or consumer any portion of this product which proves to be defective due to materials or workmanship. At all times Decko Products shall have and possess the sole right and option to determine whether to repair or replace defective equipment, parts, or components. Decko Products has the option to inspect any product returned under warranty to confirm that the warranty applies before repair or replacement under warranty is approved. This warranty sets forth Decko Products sole obligation and purchaser's exclusive remedy for defective product. Return defective product to the place of purchase or postpaid to Decko Products, Attn: Warranty Dept., 2301 Traffic Street N.E., Minneapolis, MN 55413 for warranty consideration.

WARRANTY PERIOD - PRODUCTS:

If, within the duration of product use by the original user, this product proves to be defective due to materials or workmanship, the product shall be repaired or replaced at Decko Products option, subject to the terms and conditions set forth in this warranty statement. Proof of purchase is required for warranty consideration. In the absence of suitable proof of the purchase date, the effective period of this warranty is 12 months from the product's date of manufacture.

LABOR, ETC. COSTS:

Decko Products shall IN NO EVENT be responsible or liable for the cost of field labor or other charges incurred by any customer in removing and/or affixing any product, part, or component thereof.

PRODUCT IMPROVEMENTS:

Decko Products reserves the right to change or improve its products or any portions thereof without being obligated to provide such a change or improvement for units sold and/or shipped prior to such change or improvement.

GENERAL TERMS AND CONDITIONS:

This warranty shall not apply to damage due to acts of God, normal wear and tear, normal maintenance services and the parts used in connection with such service, lightning or conditions beyond the control of Decko Products, nor shall it apply to products which, in the sole judgment of Decko Products, have been subject to negligence, abuse, accident, misapplication, tampering, alteration; nor due to improper installation, operation, maintenance or storage; nor to excess of recommended maximums as set forth in the instructions. Warranty will be VOID if any of the following conditions are found:

1. Product is used for purposes other than those for which it was designed and manufactured
2. Product not installed in accordance with applicable codes, ordinances, and good trade practices
3. Product connected to voltage other than indicated on nameplate
4. Pump exposed to but not limited to the following: sand, gravel, cement, grease, plaster, mud, tar, oil, gasoline, solvents or other abrasive or corrosive substances
5. Pump has been used for pumping liquids above 120°F
6. Pump allowed to operate dry (liquid supply cut off)

DISCLAIMER:

Any oral statements about the product made by the seller, Decko Products, the representatives, or any other parties do not constitute warranties, shall not be relied upon by the user, and are not part of the contract for sale. Seller's and Decko Products only obligation, and buyer's only remedy, shall be the replacement and/or repair by Decko Products of the product as described above. NEITHER SELLER NOR DECKO PRODUCTS SHALL BE LIABLE FOR ANY INJURY, LOSS OR DAMAGE, DIRECT, INCIDENTAL OR CONSEQUENTIAL (INCLUDING, BUT NOT LIMITED TO, INCIDENTAL OR CONSEQUENTIAL DAMAGES FOR LOST PROFITS, LOST SALES, INJURY TO PERSON OR PROPERTY, OR ANY OTHER INCIDENTAL OR CONSEQUENTIAL LOSS), ARISING OUT OF THE USE OR THE INABILITY TO USE THE PRODUCT, AND THE USER AGREES THAT NO OTHER REMEDY SHALL BE AVAILABLE TO IT. Before using, the user shall determine the suitability of the product for his/her intended use, and user assumes all risk and liability whatsoever in connection therewith.

THE WARRANTY AND REMEDY DESCRIBED IN THIS LIMITED WARRANTY IS AN EXCLUSIVE WARRANTY AND REMEDY AND IS IN LIEU OF ANY OTHER WARRANTY OR REMEDY, EXPRESSED OR IMPLIED, WHICH OTHER WARRANTIES AND REMEDIES ARE HEREBY EXPRESSLY EXCLUDED, INCLUDING BUT NOT LIMITED TO ANY IMPLIED WARRANTY OF MERCHANTABILITY OR FITNESS FOR A PARTICULAR PURPOSE, TO THE EXTENT EITHER APPLIES TO A PRODUCT SHALL BE LIMITED IN DURATION TO THE PERIODS OF THE EXPRESSED WARRANTIES GIVEN ABOVE.

Some states and countries do not allow the exclusion or limitations on how long an implied warranty lasts or the exclusion or limitation of incidental or consequential damages, so the above exclusion or limitations may not apply to you. This warranty gives you specific legal rights, and you may also have other rights which vary from state to state.



INSTALLATION & OPERATION MANUAL

TRANSFER PUMP

Model: 90045

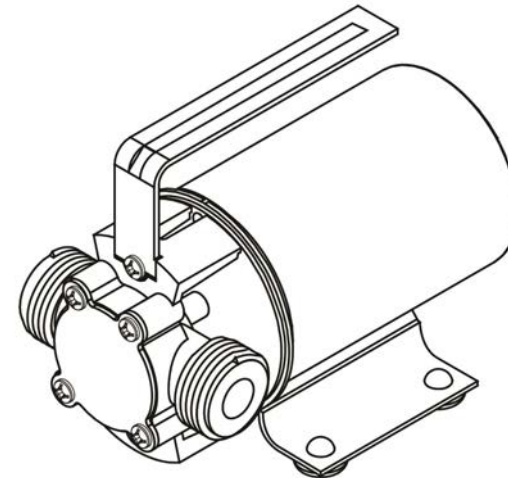

Safety Guidelines

Carefully read, understand and follow all safety instructions in this manual.

! This is the safety alert symbol. When you see this symbol, look for one of the following signal words.

⚠ DANGER Indicates a hazardous situation which, if not avoided, will result in death or serious injury.

⚠ CAUTION Indicates a hazardous situation which, if not avoided, could result in death or serious injury.

⚠ WARNING Indicates a hazardous situation which, if not avoided, could result in minor or moderate injury.

Safety Information

Read these warnings carefully. Know the application and limitations of this pump. Failure to follow these warnings could result in serious bodily injury and/or property damage.

⚠ DANGER This pump is not submersible. Do not submerge the motor in water or expose to water. Personal injury and/or death could result from electric shock.

⚠ DANGER Do not use to pump flammable or explosive liquids such as gasoline, kerosene, fuel oil, etc. Personal injury and / or death could result. Do not use this pump in a flammable or explosive environment. This pump is intended to pump clear water only.

⚠ WARNING Never touch any electrical device, including this pump, when it is touching water, in water, or even in a moist environment. Always unplug (disconnect the pump from the 12 volt battery (not included)) when working on or installing the unit.

⚠ WARNING RISK OF ELECTRICAL SHOCK. This pump has not been investigated for use in swimming pool or marine areas.

⚠ DANGER Do not touch this pump while standing in or walking on wet surfaces until all power is turned off. Failure to follow this warning could result in electric shock.

⚠ WARNING RISK OF ELECTRICAL SHOCK. Do not use the battery clip cords to carry or lift the pump. Doing so may cause the wire insulation to be exposed. Protect the cord from sharp objects, hot surfaces, oil and chemicals.

⚠ WARNING Do not run pump dry. This pump relies on water for cooling & lubrication. Running the pump dry can cause damage to the impeller and/or pump housing. It is recommended to add 1-2 tablespoons of vegetable or other light weight oil to the inlet and outlet ports before operation.

Replacement Parts

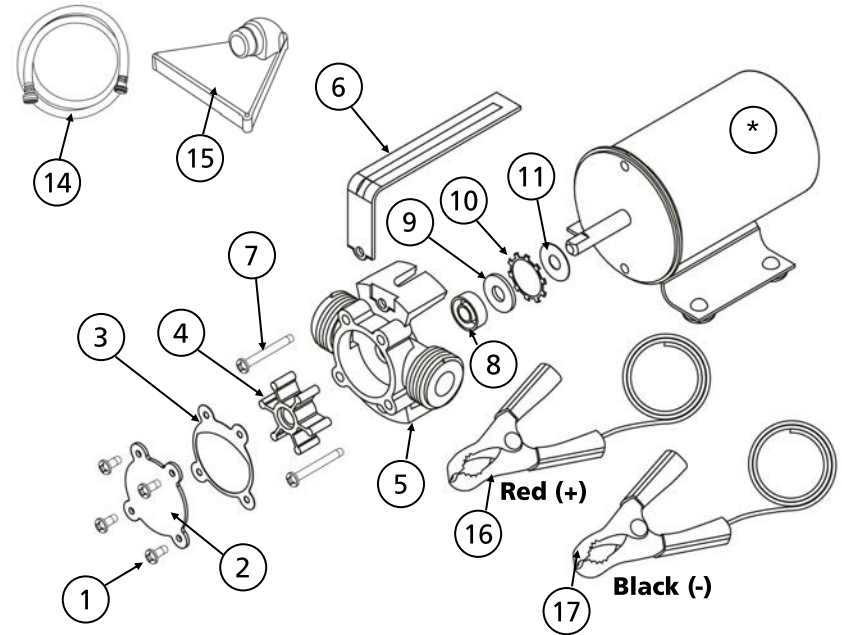

Ref#	Description	Part #
1	Screws (Housing Cover) M4-.07 x 10mm	Purchase Locally
2	Housing / Volute Cover Plate	99687
3	Gasket	99688
4	Impeller	99689
5	Housing / Volute	99690
6	Handle	99691
7	Handle / Housing Screw M5-.08 x 30mm	Purchase Locally
8	Shaft Seal	99692
9	Felt Washer	99693
10	Star Retaining Washer	99694
11	Slinger Washer (18mm OD x 8mm ID x 2mm)	99695
12	Motor Brush (2 per set)	99696
13	Brush Cap	99697
14	Suction hose	99698
15	Suction attachment	99699
16	Positive battery clip	
17	Negative battery clip	

* Not Replaceable

For Parts or Assistance, please call 1-800-495-9278

Troubleshooting

PROBLEM	POSSIBLE CAUSES	HOW TO CORRECT
If the pump does not start or run	Pump is not connected correctly to the 12 volt battery	Connect pump to 12 volt battery (not included)
	12 Volt battery is not charged	Fully charge 12 volt battery (not included) and try again
	Obstructed impeller	Check and remove obstruction
Pump will not prime or retain prime	Air leak in suction line	Check for leaks. Use thread sealant if necessary
	Suction hose kinked or coiled	Straighten suction hose
	Worn seal/gasket	Inspect and replace if necessary
	Suction lift too high	Lower pump closer to water source
If the pump runs but moves little or no water	Clogged or kinked discharge hose/pipe	Remove kink or clog
	Frozen discharge hose/pipe	Allow hose/pipe to thaw
	Air leak in suction line	Check for leaks. Use thread sealant if necessary
	12 Volt battery is low on charge	Fully charge 12 volt battery (not included) and try again
	Worn, damaged or clogged pump parts	Inspect for wear, damage or clog and clean or replace if necessary
	Discharge or suction lift exceeds pump capacity	Lower pump closer to water source and/or decrease discharge height
Pump Leaks	Worn shaft seal	Inspect and replace if necessary
	Worn housing gasket	Inspect and replace if necessary
	Loose housing plate screws	Tighten screws

Specifications

HP	Volts	Amps	Hz	Suction/Discharge	Max. Liquid Temperature	Cord Length
1/10	12	2.3	60	3/4" GHT	120°F	2 Feet

Installation

⚠ DANGER Always disconnect the power source before attempting to install, service or perform maintenance. If the power source is out of sight, lock and tag in the off position to prevent unintended power application. Failure to do so could result in fatal electric shock.

1. The inlet and discharge ports are 3/4" garden hose thread. This pump includes a 6 foot suction hose and suction attachment. Standard garden hose can be threaded onto the pump discharge. See Figure 1. Use 1/2" or larger garden hose.
2. The maximum suction lift of the pump is 7 feet. Keep the suction and discharge hoses as short and straight as possible. Do not kink or coil hose as that will greatly reduce water flow. The discharge hose should be no longer than 25'.
3. Use a screen or strainer (not included) when pumping water that contains debris

⚠ CAUTION Do not run the pump dry. Running the pump dry will cause damage to the impeller and result in premature failure of the pump. Running the pump dry will also void the warranty. It is recommended to add 1-2 tablespoons of vegetable oil to the inlet and outlet of the pump before each use to prevent impeller damage and to aid in priming.

1. Fill the suction hose with clean water and attach it to the inlet port of the pump. Make sure there is a gasket inside the hose connection to ensure an airtight seal.
2. Attach the suction attachment to the male end of the suction hose. The use of the suction attachment is optional.
3. Connect the discharge hose to the outlet port of the pump.

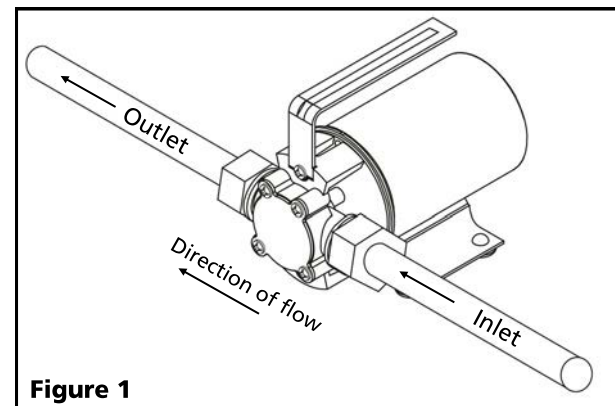
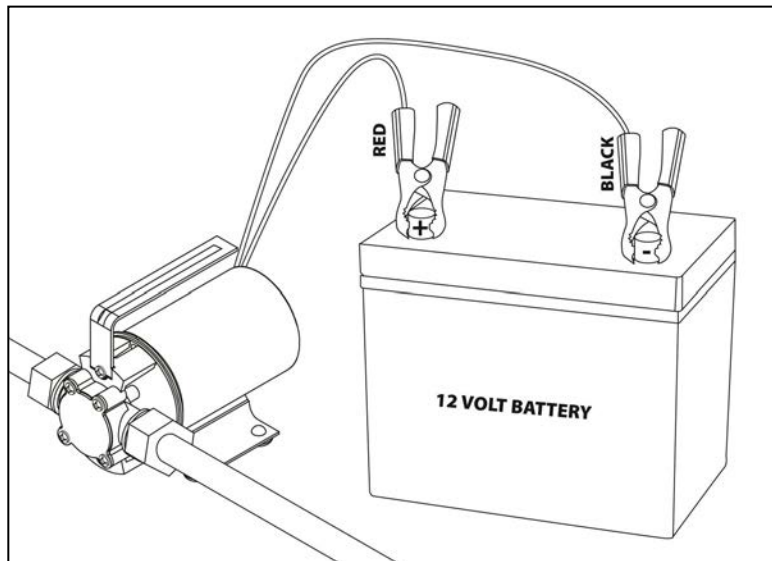

Figure 1

Operation

1. Once the suction and discharge hoses are connected to the pump you are ready to operate the pump. A 12 volt battery is required and is not included.
2. Grasp the black negative battery clip connected to the pump. Squeeze the black clips handle to open and attach the clip to the negative (-) battery post. (12 volt battery not included)
3. Grasp the red positive battery clip connected to the pump. Squeeze the red clips handle to open and attach the clip to the positive (+) battery post. (12 volt battery not included)
4. The pump should prime and start pumping within 30 seconds of starting depending on the length of suction hose. If the pump does not move water within 30 seconds, turn off the pump and check the connections.
5. When finished pumping unplug the red positive (+) clip turn the unit off.



Maintenance

⚠ DANGER Always disconnect the power source before attempting to install, service or perform maintenance. If the power source is out of sight, lock and tag in the off position to prevent unintended power application. Failure to do so could result in fatal electric shock.

⚠ WARNING Allow the pump to cool before servicing. The motor may be extremely hot and could result in personal injury.

Maintenance (continued)

IMPELLER / GASKET REPLACEMENT

1. Unplug both battery clips from the battery
2. Disconnect suction and discharge hoses.
3. Empty remaining water from pump housing.
4. Remove the four housing plate cover screws.
5. Remove worn or damaged impeller. Note the direction of the impeller vanes.
6. Clean the inside of the pump housing and apply a small amount vegetable oil, petroleum jelly or other lubricant to the pump housing and outer diameter of the impeller.
7. Align the flat on the impeller bore with the flat on the motor shaft. Push the impeller onto the motor shaft while turning the impeller in a clockwise direction.
8. Place a new gasket on the pump housing, align the holes and replace the housing cover plate. Securely tighten the housing plate screws.

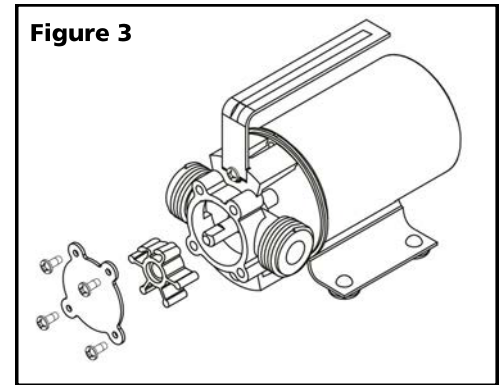

Performances

NOTICE Height and/or hose restriction will reduce the pump output performance. It is recommended to use the same size or larger pipe as the pump discharge for optimum performance. Keep the hose length as short and straight as possible. Performance based on fully charged 12 volt battery.

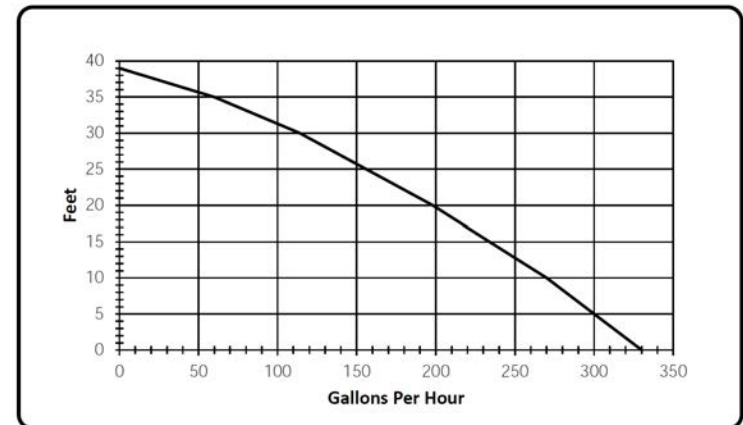

Discharge Height	0'	10'	20'	30'	35'
Gallons Per Hour	330	270	198	114	60