



COUNTYLINE®

SKU# 1261517



1. Engine is shipped with 10W-30 oil.
2. Hydraulic reservoir includes AW32 hydraulic oil.
3. Use two people before starting to assembly the log splitter.
4. Tools required: Large philips screw driver, wooden hammer, band cutter, 17, 19, 22 & 32mm wrenches.

STEP 1:

Remove outer carton sleeve then remove sides and top of crate using hammer or crowbar.

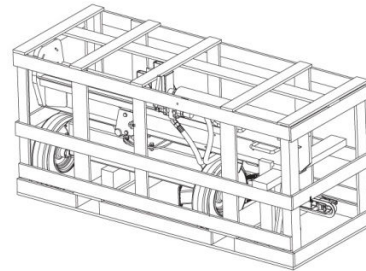

STEP 2:

Remove the tow bar assembly from the crate.

Remove the valve handle fix pin from valve and reinstall with handle in vertical position.

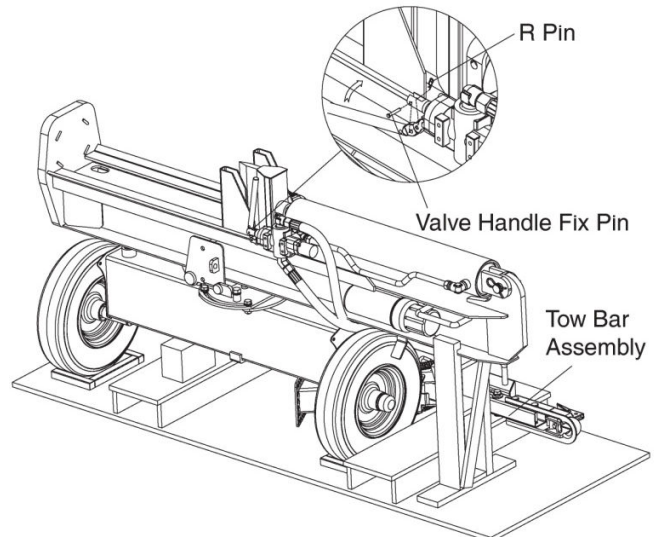

STEP 3:

Remove items 55, 79 and 80 (M14x30 hex bolt, Ø14 lock washer, Ø14 flat washer) from the rotating mechanism.

Lift up the foot piece end of the beam and rock forward.

Secure the beam pivot by reinstalling items 55, 79 and 80.

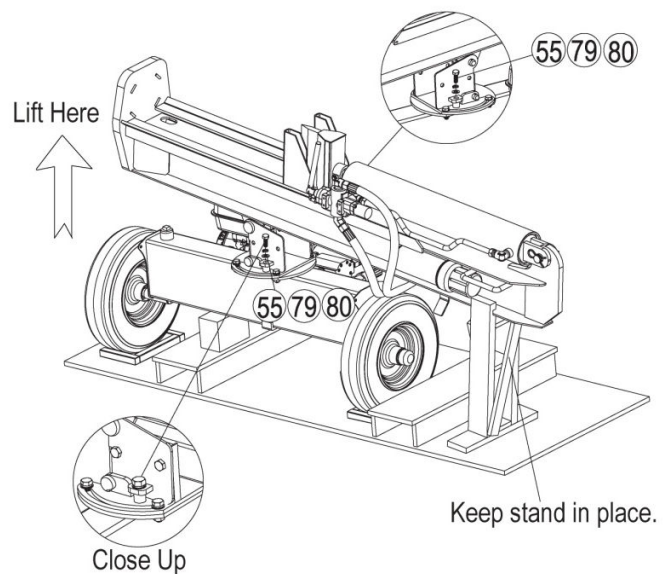

STEP 4:

Remove the two sets of items 57, 65 and 95, that are **painted red** (M12x35 red hex bolts, Ø12 flat washers and Ø12 lock washers) from the outer portion of the rotating assembly.

Loosen the other two bolts on rotating assembly which will allow beam assy. to rotate.

Rotate the beam 90 degrees towards the front while simultaneously lifting beam to vertical position.

Reinstall the red bolts and tighten the other outer two bolts.

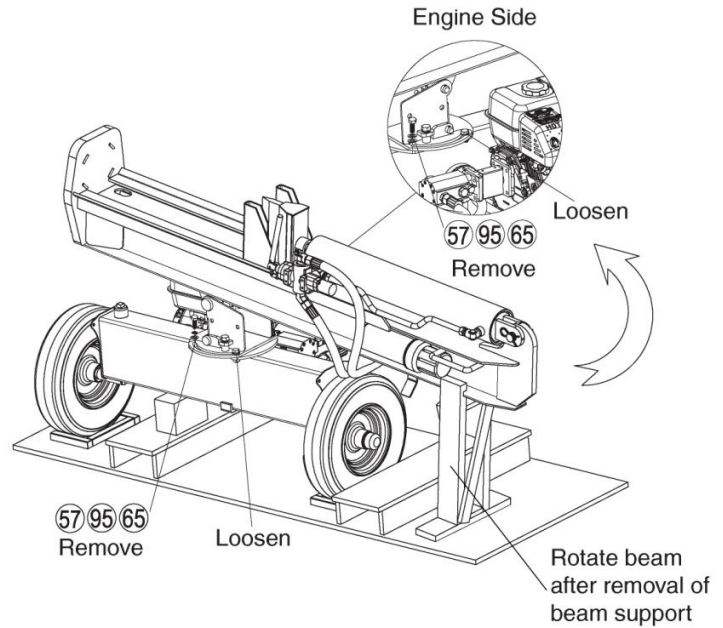
**STEP 5:**

Loosen connector of hydraulic hose with 32mm wrench or adjustable wrench, adjust the hydraulic hose to a non-kinked state, then retighten the connector.

Insert the tow bar assembly into the rotating mechanism, secure using items 24, 65 and 13 (M12x150 hex bolt, Ø12 flat washer and M12 nylon lock nut).

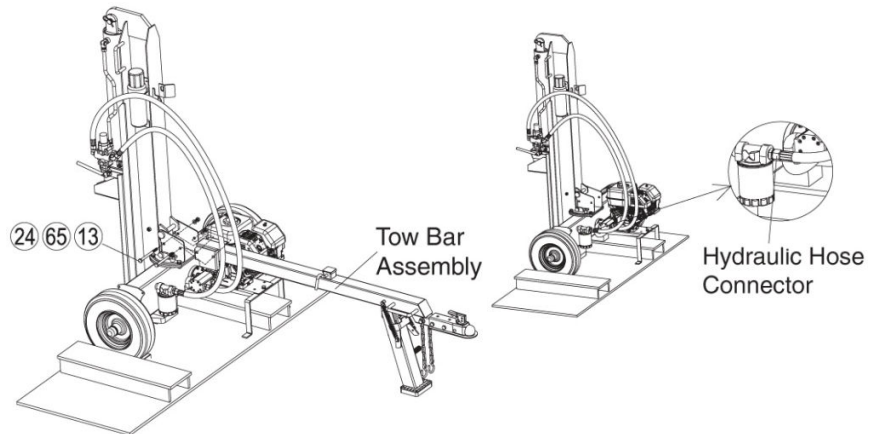
**STEP 6:**

Lower the beam to the horizontal position. Remove item 26 (fill plug) from manual canister and replace plastic plug.

STEP 7:

Remove the engine support leg with 17mm wrench and the steel wheel chocks.

Roll the splitter off of the crate and check to make sure all hardware has been tightened.

STEP 8:

Check all fluid levels and add if necessary.

