

CROSLEY

FURNITURE

Square Upholstered Seat Bar Stool

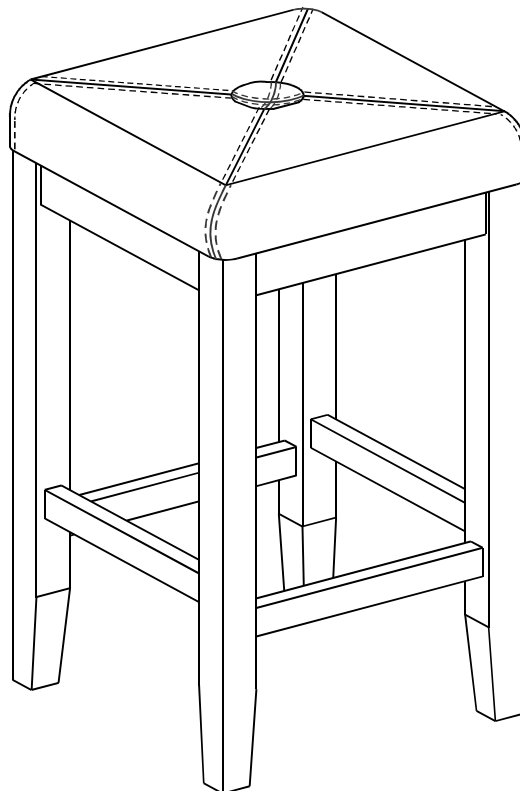



CF500524/CF500529

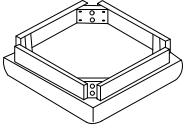
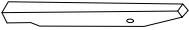
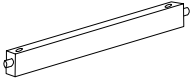

PART LIST

<div data-bbox="79 118 145 165" data-label="Text">A2</div> 	<div data-bbox="352 118 411 165" data-label="Text">B2</div> 	<div data-bbox="620 118 679 165" data-label="Text">C2</div> 
<div data-bbox="153 439 296 501" data-label="Text">Seat Frame 2 PCS</div>	<div data-bbox="395 439 544 501" data-label="Text">Leg (L & R) 8 PCS</div>	<div data-bbox="659 439 831 501" data-label="Text">Side Stretcher 8 PCS</div>

HARDWARE LIST

<div data-bbox="92 669 145 712" data-label="Text">#1</div> 	<div data-bbox="352 669 405 712" data-label="Text">#2</div> 	<div data-bbox="620 669 673 712" data-label="Text">#3</div> 	<div data-bbox="876 669 928 712" data-label="Text">#4</div> 	<div data-bbox="1134 669 1187 712" data-label="Text">#5</div> 
<div data-bbox="113 965 320 1066" data-label="Text">M6 x 60mm Bolt 16 PCS (Extra 1)</div>	<div data-bbox="395 1003 603 1066" data-label="Text">Spring Washer 16 PCS (Extra 1)</div>	<div data-bbox="651 1003 858 1066" data-label="Text">Flat Washer 16 PCS (Extra 1)</div>	<div data-bbox="922 1003 1098 1066" data-label="Text">Allen Wrench 1PC</div>	<div data-bbox="1177 965 1385 1066" data-label="Text">M4 x 38mm Screw 16 PCS (Extra 1)</div>

ADDITIONAL TOOLS (Not Provided)

Note: It is not recommended to use power tools during assembly.

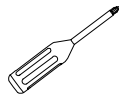

Phillips Head Screwdriver

Step 1. Attach legs (part B2) to seat frame (part A2) using bolts (part #1), spring washers (part #2), flat washers (part #3) and allen wrench (part #4).

NOTE: Do not tighten bolts at this time.

NOTE: The legs (part B2) are marked "R" for right and "L" for left."

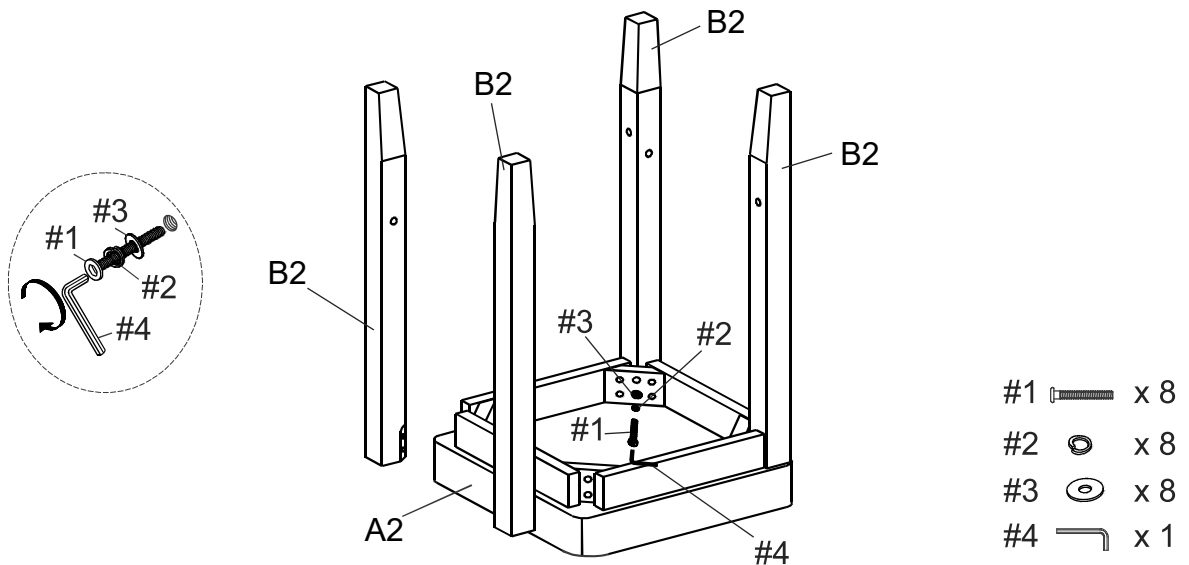

Step 2. Insert side stretchers (part C2) into legs (part B2) using screws (part #5) and phillips head screwdriver.

NOTE: Please fully tighten all bolts at this time.

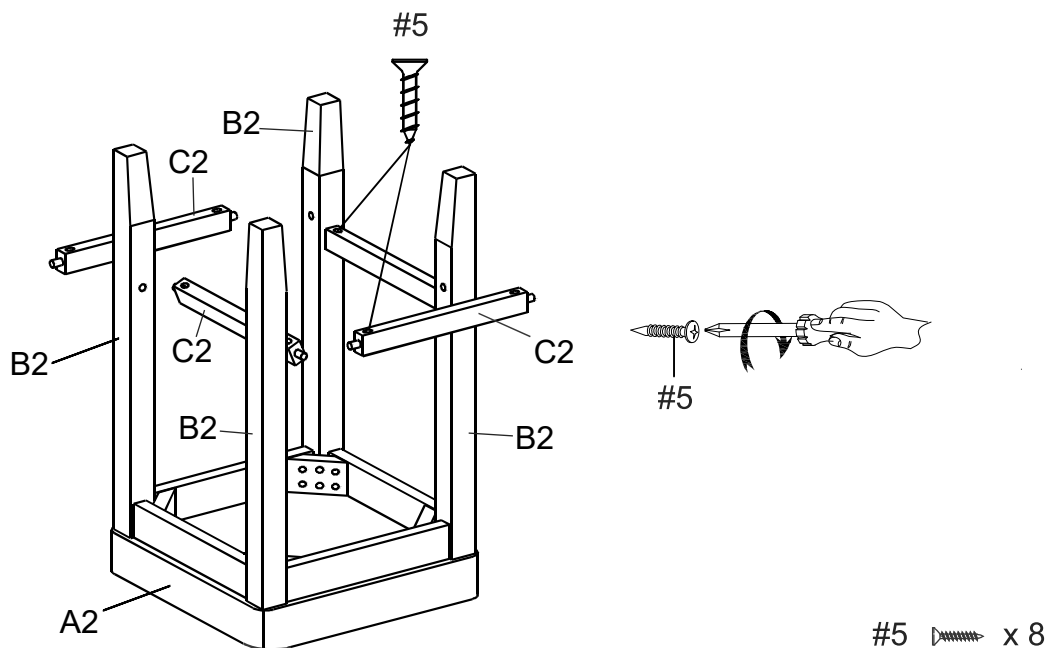

Step 3. Carefully turn unit upright. Repeat steps 1-2 to assemble remaining stool.

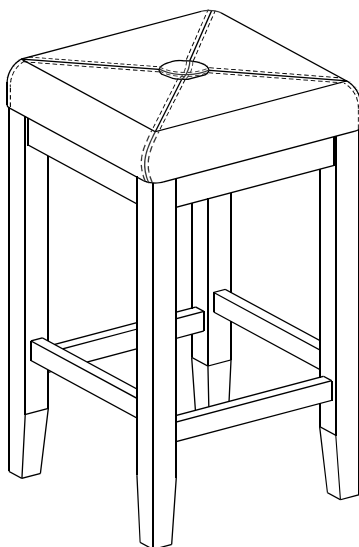

PO#
MODEL#
CF500524/CF500529
MADE IN MALAYSIA