

CROSLEY

FURNITURE

Upholstered Saddle Seat Bar Stool

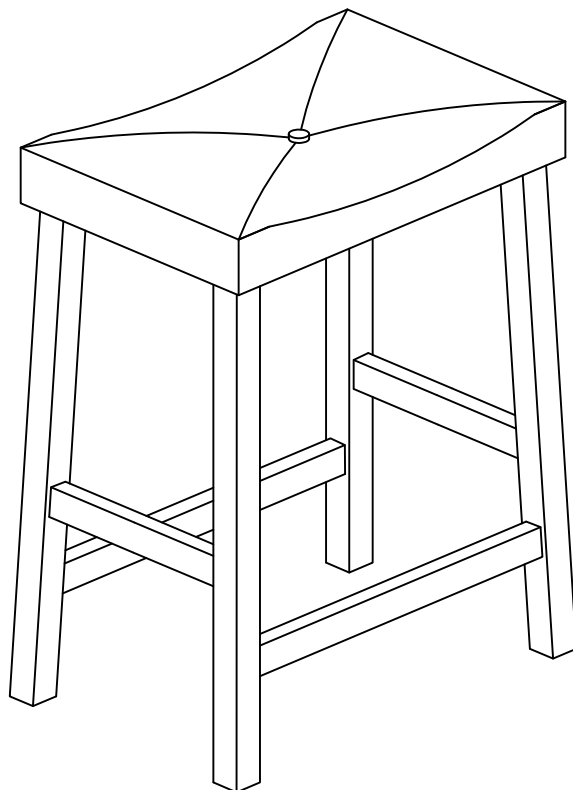

CF500224/CF500229

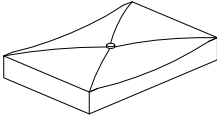
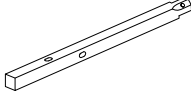
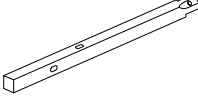
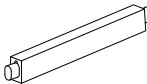
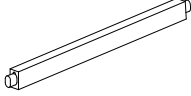

PART LIST

<div style="border: 1px solid black; padding: 5px; text-align: center;">A</div> 	<div style="border: 1px solid black; padding: 5px; text-align: center;">B</div> 	<div style="border: 1px solid black; padding: 5px; text-align: center;">C</div> 	<div style="border: 1px solid black; padding: 5px; text-align: center;">D</div> 	<div style="border: 1px solid black; padding: 5px; text-align: center;">E</div> 
<p style="text-align: center;">Seat Frame 2 PCS</p>	<p style="text-align: center;">Left Leg 4 PCS</p>	<p style="text-align: center;">Right Leg 4 PCS</p>	<p style="text-align: center;">Side Stretcher 4 PCS</p>	<p style="text-align: center;">Front Stretcher 4 PCS</p>

HARDWARE LIST

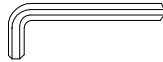
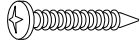
<div style="border: 1px solid black; padding: 5px; text-align: center;">#1</div>  <p style="text-align: center;">M6 X 60</p>	<div style="border: 1px solid black; padding: 5px; text-align: center;">#2</div> 	<div style="border: 1px solid black; padding: 5px; text-align: center;">#3</div> 	<div style="border: 1px solid black; padding: 5px; text-align: center;">#4</div> 	<div style="border: 1px solid black; padding: 5px; text-align: center;">#5</div>  <p style="text-align: center;">4 x 38mm</p>
<p style="text-align: center;">Bolt 8 PCS (Extra 1)</p>	<p style="text-align: center;">Spring Washer 8 PCS (Extra 1)</p>	<p style="text-align: center;">Flat Washer 8 PCS (Extra 1)</p>	<p style="text-align: center;">Allen Wrench 1 PC</p>	<p style="text-align: center;">Screw 16 PCS (Extra 1)</p>

ADDITIONAL TOOLS (Not Provided)

Note: It is not recommended to use power tools during assembly.



Phillips Head Screwdriver

Step 1. Insert side stretcher (part D) into left leg (part B) and right leg (part C).
Insert screws (part #5) into predrilled holes of side stretcher (part D) and secure using
Phillips head screwdriver.
Repeat this step to assemble remaining legs.

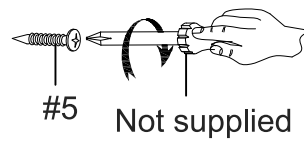
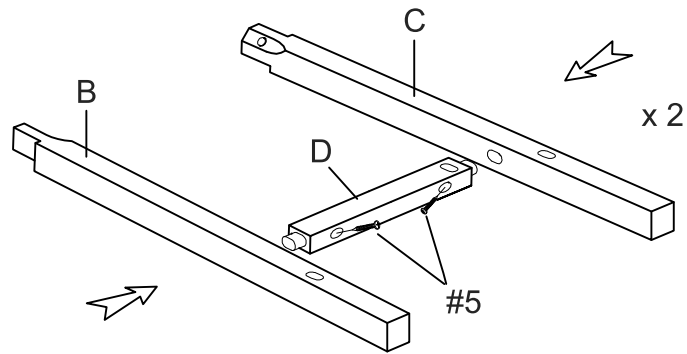

#5  x 4

Step 2. Insert front stretchers (part E) into legs (parts B & C).

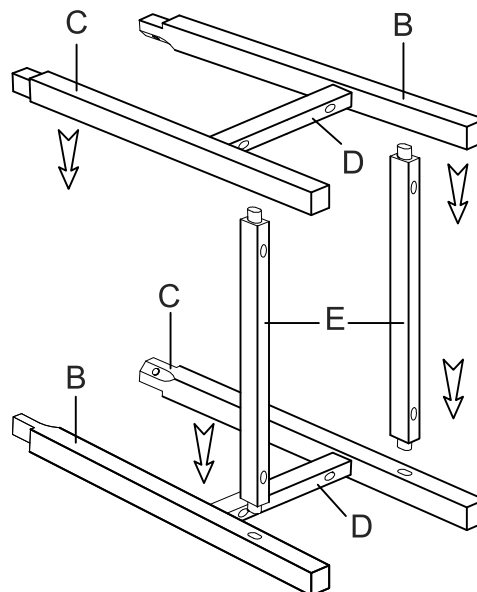

Step 3. Place seat frame (part A) upside down on a soft, flat surface, as shown. Insert legs (parts B & C) into seat frame (part A) and secure using bolts (part #1), spring washers (part #2), flat washers (part #3) and allen wrench (part #4). Insert screws (part #5) into front stretchers (part E) and secure using phillips head screwdriver.

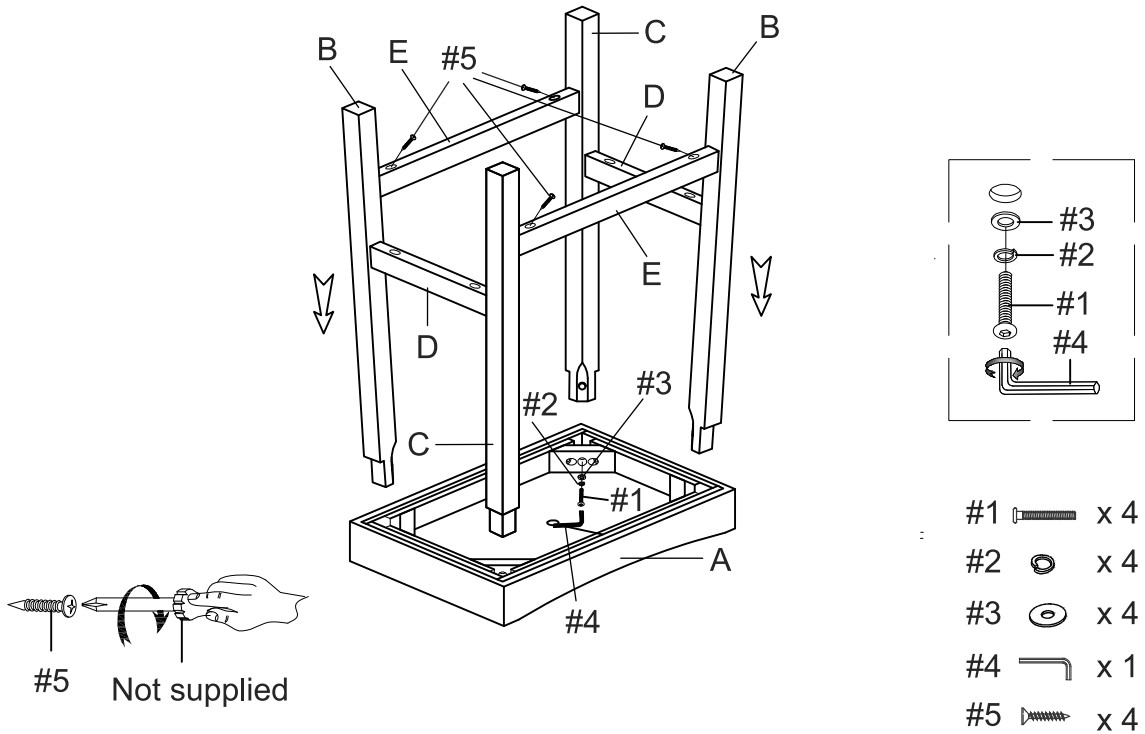

Step 4. Carefully turn unit upright. Repeat steps 1-3 to assemble remaining stool.

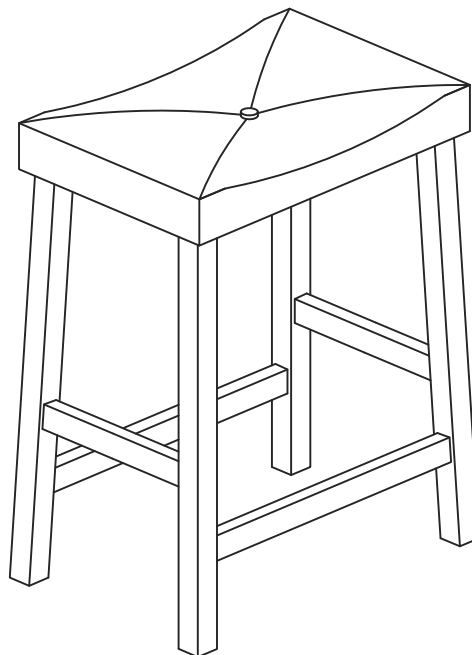

PO#
 MODEL#
 CF500224/CF500229
 MADE IN MALAYSIA