

7' Land Plane

80119070YEL

THANK YOU FOR PURCHASING THIS PRODUCT

Congratulations on your purchase. Behlen Country has been in the business of providing quality equipment to landowners for more than 80 years. Our 3-Point Equipment will provide many years of service when maintained by the operator and used in accordance with the capabilities of the product. For questions about this product, or for parts inquiries, please contact our Customer Service Center listed below.

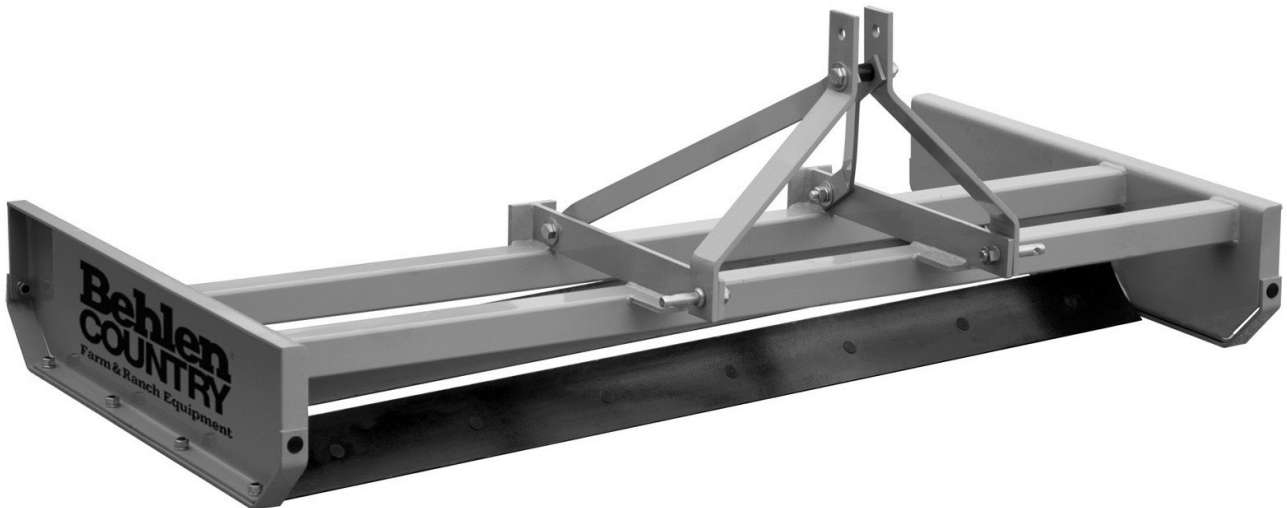

STATEMENT OF POLICY

It is the policy of Behlen Country to improve its products where it is possible and practical to do so. Behlen Country reserves the right to make changes or improvements in design and construction at any time, without incurring the obligation to make these changes on previously manufactured units.

Behlen[®]
COUNTRY

CUSTOMER SERVICE CENTER

PO Box 569
Columbus, NE 68602-0569

Ph: 800-447-2751 Fax:
(402) 563-7447
www.behlencountry.com

SAFETY

READ AND FOLLOW THE INSTRUCTIONS IN THIS MANUAL, ESPECIALLY IN THE SAFETY SECTION. FAILURE TO DO SO COULD RESULT IN SERIOUS INJURY OR DEATH.



THIS SYMBOL MEANS ATTENTION! BE ON THE ALERT! YOUR SAFETY IS INVOLVED!

TAKE NOTE! THIS SAFETY ALERT SYMBOL IS FOUND THROUGHOUT THIS MANUAL. THIS SYMBOL IS USED TO CALL YOUR ATTENTION TO INSTRUCTIONS CONCERNING YOUR PERSONAL SAFETY AND THE SAFETY OF OTHERS.

CRITICAL TERMS:

The critical terms **CAUTION**, **WARNING**, and **DANGER** are used with the safety messages in this manual and with each safety decal. They are defined as follows:



CAUTION



CAUTION: Indicates a potentially hazardous situation that, if not avoided, **CAN** result in minor or moderate injury. It also may be used to alert against unsafe practices.



WARNING



WARNING: Indicates a potentially hazardous situation that, if not avoided, **MAY** result in serious injury or death, and includes hazards that are exposed when guards are removed. It may also be used to alert against unsafe practices.



DANGER



DANGER: Indicates an immediate hazardous situation that, if not avoided, **WILL** result in serious injury or death. This Critical Term is to be limited to the most extreme situations, typically for machine components that, for functional purposes, cannot be guarded.

EQUIPMENT SAFETY GUIDELINES

• Safety of the operator and bystanders is one of the main concerns in designing and developing a Land Plane. However, every year accidents occur which could have been

avoided by a few moments of thought and a more careful approach to handling equipment. You, the operator, can avoid many accidents by observing the following precautions and insist those working with or for you adhere to them.

- In order to provide a better view, certain illustrations in this manual may show an assembly with a safety guard removed. However, equipment should never be operated in this condition. Keep all guards in place. If guard removal becomes necessary for repairs, reinstall the guard prior to use.
- Heed all safety decals and replace any that are not legible or missing. The locations of such safety decals are indicated in this manual.
- Never operate this equipment while using alcoholic beverages or drugs that can hinder alertness or coordination. Consult your doctor about operating this machine while taking prescription medications.
- Under no circumstances should children under the age of 18 be allowed to work with or around this equipment. Do not allow anyone to operate or assemble this equipment until they have read this manual and have developed a thorough understanding of the safety precautions and operation. Review safety instructions with all users often.
- This equipment is dangerous to anyone unfamiliar with its operation. The owner/operator is responsible for reading and following all of the instructions in the manual. The operator should be a responsible, properly qualified and physically able person familiar with farm machinery and competent in this equipment's operation.
- Never exceed the limits of a piece of machinery. If its ability to do a job, in a safe manner, is in question - **DON'T TRY IT.**
- Use a tractor equipped with a Roll Over Protective System (ROPS) and seat belts. Only properly trained people should operate this machine. Always stop the PTO, set break, shut off the tractor engine, remove the tractor key, and allow implement to come to a complete stop before dismounting tractor. **Never leave equipment unattended with tractor running.**

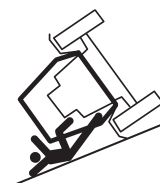

BEFORE YOU START!!

Read the safety messages on the implement and as shown in the manual. Observe the rules of safety and common sense!

Important Safety Information

Working with unfamiliar equipment can lead to careless injuries. Read this manual and the manual for your tractor before assembly or operating, to acquaint yourself with both machines. It is the Owner/Operator's responsibility, if this machine is used by any person other than yourself, or is loaned or rented, to make certain prior to operating:

1. The operator's manual is read and understood.
2. Safety issues are understood and followed, and proper usage is understood.

The use of this equipment is subject to certain hazards which cannot be protected against by mechanical means or product design. All operators of this equipment must read and understand this entire manual, paying particular attention to safety and operating instructions, prior to use. If there is something in this manual you do not understand, ask your dealer or manufacturer, to explain it to you. Improper use can occur on machines that are loaned out or rented to someone who has not read the owner's manual and is not familiar with a Land Plane.



CAUTION - For safe operation, read rules and instructions carefully.

The following safety precautions should be thoroughly understood before attempting to begin the assembly of this machine.

1. Select an area for assembly that is clean and free of debris which might cause persons working on the assembly to trip.
2. Do NOT lift heavy parts or assemblies. Use a crane, jack, tackle, fork trucks or other mechanical devices.
3. Preview the assembly instructions in your operator's manual before proceeding further.
4. If the assembly instructions call for parts or assemblies to be blocked up, use only

blocking material that is in good condition and is capable of handling the weight of the assembly to be blocked. Also insure that the blocking material is on a clean, dry surface.

5. NEVER put hands, or any part of the body, under blocked up assemblies if at all possible.
6. After completing assembly, thoroughly inspect the machine to be sure that all nuts, bolts, or any other fastened assemblies have been thoroughly tightened.
7. Before operating the machine, thoroughly READ and UNDERSTAND the operation section of your operator's manual.
8. Before operating, READ the maintenance section of your operator's manual to be sure that any parts requiring lubrication are serviced to avoid any possible damage.
9. Before operating equipment - If you have any questions regarding the proper assembly or operation, contact your Behlen Country dealer or representative.

Safety Information

This Land Plane was designed for one-man operation from the tractor seat. Most

 accidents occur because of neglect or carelessness. It is the responsibility of the operator to see that no one is within twenty-five feet (25') of the blade when it is in operation. Do not operate the implement with another person near, or in contact with, any part of the Land Plane. Serious personal injury or death may result if any attempt is made to assist operation by hand.

Please remember it is important that you read and heed the safety decals on the Land Plane, and the safety rules set forth herein. Clean or replace all safety stickers if they cannot be clearly read and understood. They are there for your safety as well as the safety of others. The safe use of this machine is strictly up to you, the operator.

All things with moving parts are potentially hazardous. There is no substitute for a cautious, safety-minded operator who recognizes potential

 hazards and follows reasonable safety practices. The manufacturer has designed this implement to be used with all its safety equipment properly attached, to minimize the chance of accidents. Study this

manual to make sure you have all the safety equipment attached.

When maneuvering close to buildings or passing through narrow areas, be sure to allow sufficient clearance for the implement and tractor. **NEVER** operate tractor and implement under trees with low hanging limbs. Operators can be knocked off tractor and run over by implement.

This Land Plane is only designed for speeds less than 5 mph. Reduce speed on rough surfaces.

When the use of hand tools is required to perform any part of assembly, installation, adjustment, maintenance, repairing, removal or moving the blade, be sure the tools used are designed and recommended by the tool manufacturer for that specific task.

Personal protection equipment including hard hats, safety glasses, safety shoes, and gloves are recommended during assembly, installation, operation, adjustments, maintenance, repairing, removal, or moving the Land Plane.

Always use two people to handle heavy, unwieldy components moving the Land Plane.

Never place any part of your body where it would be in danger, if movement should occur during assembly, operation, maintenance, repairing, or moving the Land Plane.

Never place yourself between the tractor and Land Plane while implement is in operation. When removing, or adjusting equipment, be sure your body is never under the blade.

A heavy load can cause instability of the tractor. Use extreme care during travel. Slow down on turns and watch out for bumps. The tractor may need front counterweights to counter-balance the weight of the Land Plane.

Never use alcoholic beverages or drugs which can hinder alertness or coordination while operating this equipment. Consult your doctor about operating this machine while taking prescription and some over-the-counter medications.

DO NOT ALLOW RIDERS on the Land Plane or tractor at any time. There is **NO** safe place for any riders. **NEVER ALLOW CHILDREN TO OPERATE OR BE AROUND BLADE.**

Before you operate the Land Plane, check over all pins, bolts and connections to be sure all are securely in place. Replace any damaged or worn parts immediately.

Consult local utility companies to make certain there are no buried gas lines, electrical cables, etc., in the work area before beginning operation.

Do NOT allow anyone who is not familiar with the safety rules and operation instructions to use this Land Plane.

Never replace any bolt with any length other than what is specified in this manual. A longer, or protruding fastener is more likely to grab loose clothing or gloves which can result in serious injury or death.

Watch for hidden hazards on the terrain during operation.

Turn curves or go up or down hills only at a low speed and at a gradual steering angle. Make certain that at least 20% of the tractor's weight is on the front wheels to maintain safe steering. Slow down on rough or uneven surfaces, and loose gravel.

Check that all hardware is properly installed. Always tighten all bolts to proper torque. Make sure attachment is properly secured, adjusted and in good operating condition.

Where replacement parts are necessary for periodic maintenance and servicing, genuine factory replacement parts must be used to restore your equipment to original specifications. The manufacturer will not be responsible for the use of unapproved parts and/or accessories and the damages that can result in their use.

Keep alert and watch the front as well as the rear when working with equipment. **DO NOT** operate close to ditches or creeks. Be careful to avoid catching implement on stumps or other immovable objects.

Make adjustments to implement only when it is attached to a tractor

and blocked up. Always keep all persons and children away from area when performing adjustments, service or maintenance. Worn edges can seriously affect the Land Plane's operation. Check for wear before each use and replace as necessary.



Know your controls and how to stop your tractor, engine, and implement quickly in an emergency.



Do not operate the Land Plane without checking that all movable parts are in good working order. Always use care when operating the Land Plane.

Instructions

Tractor Requirements, Preparation, and Assembly

The Land Plane is designed to fit Category 1 tractors equipped with a standard 3-Point hitch. Check the tractor's 3-Point hydraulic lift system. It should operate up and down smoothly and have enough power to lift the Land Plane. Refer to your tractor's operators manual or dealer for any adjustments necessary to put the 3-Point hydraulic lift system in good working order. (I&T shop manuals will list most specifications and adjustment instructions - available from most farm equipment dealers).

Smaller size tractors may need front counter weights to counter-balance the weight of the Land Plane. It is recommended that the tractor be equipped with a Rollover Protection System (ROPS) and a seat belt that is used.

NOTE: Land Planes are shipped with the lift arms and Cat 1 lift pins on the inside of the horizontal angles as shown below in Figure (A). They must be disassembled and put on the outside of the horizontal angles. Remove the $\frac{3}{4}$ " bolt, and the Cat 1 pins and the loosen the nuts on the Rear Lift Arms.

Fig. A

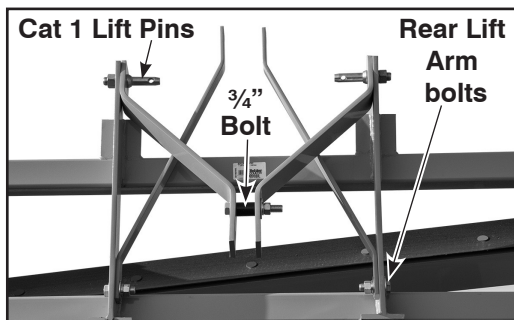

Shift up and reassemble A-frame members as shown at right. Reassemble Cat 1 Lift Pins facing outward. Tighten all nuts. A-Frame correctly assembled shown below.

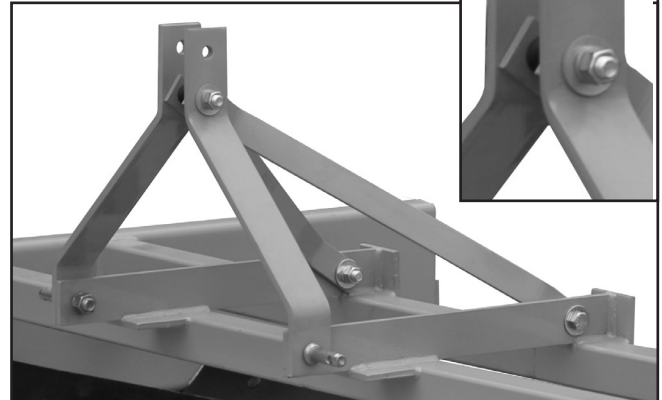

CAUTION



A heavy load can cause instability in driving a tractor. Make sure the front of the tractor is properly counter-balanced with weights. Always drive slowly, especially around turns. An unstable tractor could steer badly and possibly tip over, causing injury or death.

Mounting

1. Back tractor up to the Land Plane making sure that the lift arms of tractor are on the outside of the lift points on the Land Plane.
2. Slide lifting arms of tractor over lift pins on the Land Plane.
3. Use lynch pins (customer supplied) to secure implement to the tractor.
4. Connect top link (customer supplied) from the tractor to the top center lifting point of the Land Plane and insert hitch pin (customer supplied).
5. Make any adjustments necessary to level the blade from side to side.



CAUTION



When using blade in reverse position, extra care should be taken not to ram into piles of dirt or debris. Tractor lift arms and the Land Plane are not built to take high impact loads in this position. Ramming backwards can also dislodge operator from seat and/or tractor controls, resulting in serious injury or death.

Preparation Procedure

- Thoroughly read and understand your Operator's Manuals.
- Before beginning operation, contact your local utility company to make certain there are no gas lines, electrical cables, etc., in the work area.
- Check for ditches, stumps, holes, or other obstacles that could cause the tractor to roll.
- Be sure tractor tires and rims are in good condition. Inflate tires to proper air pressure.
- All persons should be at least twenty-five feet (25') away during operation. Clear the area of helpers, bystanders, and especially children.
- Do NOT allow anyone to stand between the hitch and blade.
- It is only recommended that tractors with wide front axles use the Land Plane. Tricycle front wheel arrangements are inherently unstable and can cause rollover accidents.
- Check the tractor master shield over the PTO stub shaft. Make sure it is in good condition and fastened securely to the tractor.
- Make sure all safety stickers are installed and in good condition. Replace if damaged.
- Do NOT allow riders. There is no safe place for anyone to ride or sit on tractor or implement.
- Check that all equipment is properly installed and securely attached to the tractor.

Operation

If you have any questions regarding the proper operation of this Land Plane, contact your dealer or the manufacturer.

It is the responsibility of the operator to see that no one else is within twenty-five feet (25') of the tractor when it is started.

- Raise or lower the Land Plane to determine how much or how little material you would like to move.
- The deeper you set the blade, the slower you will need to go with your tractor and the more stress you put on the Land Plane as well as the

tractor. It is better to take less material and do it more times than to try to do it all in one pass.

- This unit is not made to push, only to be pulled. Pushing can damage the Top Link on the tractor as well as the tractor lift arms.
- Lower blade to ground and start moving forward. Your speed will be determined by the condition of the soil. You may need to use less or more angle depending on the job.
- Speed of the tractor should not exceed 5 mph.
- When you are turning, lift the unit from the ground.
- Pass diagonally through sharp dips and avoid sharp drops to prevent "hanging up" the tractor and blade.
- Watch for hidden hazards on the terrain during operation.



WARNING



DO NOT TAKE A DITCH AT 90° (straight on)!
Always go in at an angle or damage may occur.



CAUTION



Before dismounting power unit or performing any adjustments to the Land Plane, make sure to disengage power to equipment, lower 3-Point hitch and all raised components to the ground, operate valve levers to release any hydraulic pressure, set parking break, stop engine, remove key and allow implement to come to a complete stop before dismounting tractor. Never leave equipment unattended with tractor running.

It is essential that everyone involved in the operation, transportation, maintenance, and storage of this equipment be aware, concerned, prudent and properly trained in safety.



DANGER



The cutting edge of the blades are extremely sharp. Exercise extreme caution when working around or near the cutting edges. Failure to stay clear of the cutting edges can result in serious injury.



CAUTION



Stop **IMMEDIATELY** upon striking an obstruction. Turn off engine, remove key, inspect, and repair any damage before resuming operation. Never leave the seat of the tractor while engine is engaged.



CAUTION



Watch for hidden obstructions, like buried pipes, rocks, concrete piers or uneven slabs of concrete when operating the Land Plane as damage to the unit can occur. This is especially true with snow removal.

Transportation Guidelines

Unit should be lifted as high as the tractor will allow being sure the unit is clear of the ground when transporting.

Care should be taken that at least 20% of tractor weight should be on the front tires. A safe speed should be maintained during transportation.

Tractor weight ballast may be needed to even out weight to maintain proper steering.

Do **NOT** lower unit to pavement, blacktop or gravel road while transporting. Damage to the unit can occur.

When transporting on roadways always use a Safety Sign, and drive in a manner to allow other vehicles to pass you safely.



WARNING



When traveling on public roads, whether at night or during the day, use accessory lights and devices for adequate warning to operators of other vehicles. Comply with all federal, state, and local laws.

Maintenance

Before servicing the Land Plane, engage the parking break or place the transmission in "PARK", shut off tractor, and remove key.

1. Make certain any safety and instruction decals are attached to the Land Plane 3-Point hitch. If they are lost, damaged, or painted over, order replacements from Behlen Country at 1-800-447-2751.
2. Clean unit of dirt and debris to minimize rusting and wear.
3. Keep cutting edges sharp. Sharp cutting edges work easier and better. Check more often if working in rocky soil conditions.
5. Replace any worn or damaged parts immediately.
6. Check all bolts and nuts to make sure they are tight.
7. **NEVER** go underneath equipment. Never place any part of the body underneath equipment or between movable parts even when the engine is turned off. Servicing this Land Plane does not require going underneath.

Replacing Cutting Edge

To service the Land Plane when attached to the tractor, it must be blocked off the ground.

1. Place two 4" x 4" blocks under each side frame of the Land Plane.
2. Lower Land Plane to rest securely on the blocks.
3. Remove the lock nuts and plow nuts from the blade. Turn cutting edge over and use new edge, or replace it if both sides have been used.
4. Reattach cutting edge to Land Plane and secure with plow bolts and hex nuts previously removed, and tighten.

Cleaning And Storage

After Each Use

- Remove large debris such as clumps of dirt, grass, crop residue, etc. from Land Plane.
- Inspect Land Plane and replace worn or damaged parts
- Replace any safety decals that are missing or not readable.

Before Extended Storage

- Follow cleaning instructions from above.
- Wash implement using low-pressure water spray.
- Be careful when spraying near scratched or torn safety decals or near edges of decals as water spray can peel decals off surface.
- Spraying near chipped or scratched paint can also cause paint to peel more.
- Inspect implement for worn or damaged parts and replace any missing safety stickers.
- Sand down scratches and edges where paint is missing and repaint to prevent rust.
- Store the implement in a shed or under a tarpaulin to protect it from the weather. The blade should be resting on boards or some other object. Keep out of soil when storing.
- Store in clean, dry place away from human activity or livestock.

WARRANTY

This unit carries a 1 year warranty, with the exception of wear parts. Dated proof of purchase required on all claims.

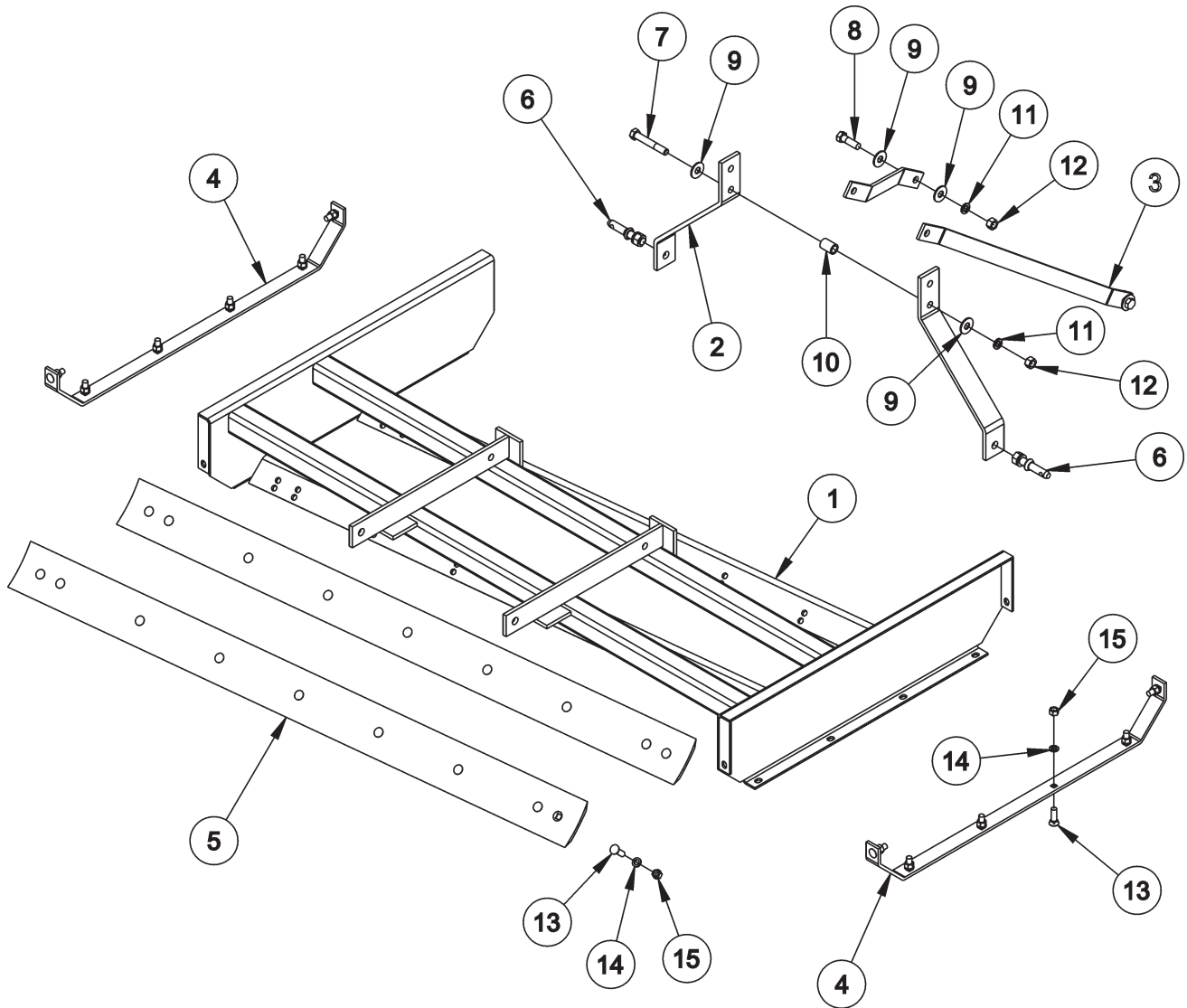

Parts List for Land Plane

Ref. No.	Part No.	Description	Qty.
1	80509070YEL	7' Land Plane Weldment	1
2	80627710YEL	BB Front A-Frame	2
3	80627690YEL	BB A-Frame Brace Bar	2
4	80609110YEL	Land Plane Wear Skid	2
5	3018380	3/8" x 6" x 7' Cutting Edge	2
6	3018352	Cat. 1 Universal Lift Pin w/Hardware	2
7	H00BOLTP030	Bolt HHC 3/4" x 5" Gr 5 (plated)	1
8	H00BOLTP029	Bolt HHC 3/4" x 2 1/2" Gr 5 (plated)	2
9	3948004	Washer, Flat 3/4" Plated	6
10	80627595	Tube Bushing, A-Frame	1
11	3948051	Washer, Std. Lock 3/4"	3
12	2688006	Nut, Hex 3/4" NC	3
13	3018554	Bolt, Plow 5/8-11 x 2" #3	30
14	3948019	Washer, Lock 5/8" ZP	30
15	2688022	Nut, Hex 5/8-11 ZP	30