

Installation Instructions

Part Numbers:

24887
60304
77275

NISSAN VERSA SEDAN

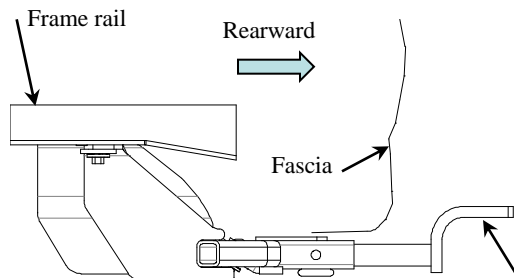

Hitch Shown In Proper Position

Equipment Required: Pull wire, Galvanic isolators (provided), lubricant or soapy water, tin snips,
Fastener Kit: 24887F
Wrenches: M10, 11/16, & 3/4
Drill Bits: 1/4"

Drawbar Kit:
3592

Drawbar must be used in the **RISE** position only.

Do Not Exceed Lower of Towing Vehicle Manufacturer's Rating or

2000 LB (908 Kg) Max Gross Trailer Weight
200 LB (90.8 Kg) Max Tongue Weight

Wiring Access Location: SUV3, 4

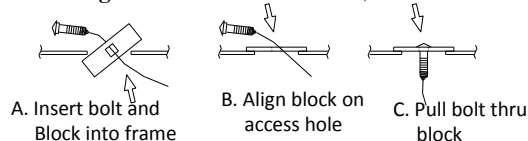

Figure 3

Pull wire Procedure

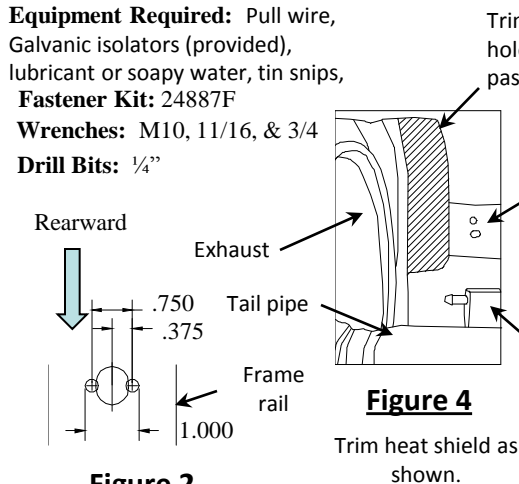

Figure 4

Trim heat shield as shown.

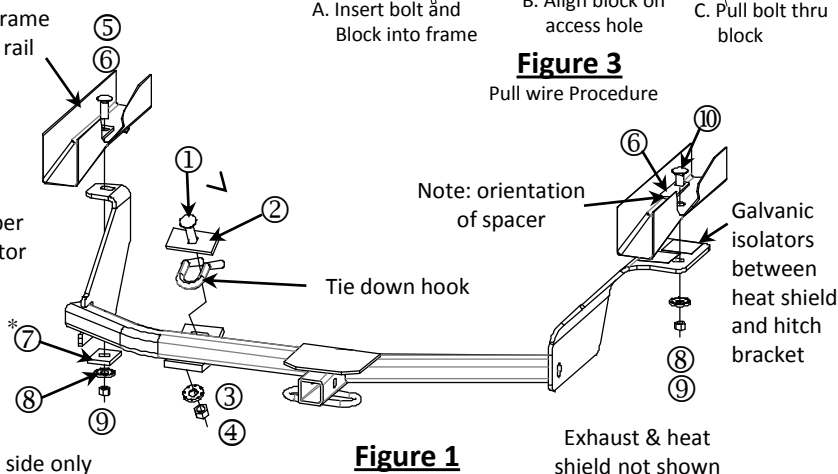

Figure 1

*Drivers side only

Exhaust & heat shield not shown

Access hole modification to allow for block and carriage bolt.

①	Qty. (1)	Carriage bolt 1/2-13 X 2.00 GR5	⑥	Qty. (2)	Spacer 1/8" X .90 X 3.00
②	Qty. (1)	Spacer 1/4" x 1.50 x 3.00	⑦	Qty. (1)	Spacer 1/4" X 1.50 X 2.00
③	Qty. (1)	Conical washer 1/2"	⑧	Qty. (2)	Conical washer 7/16
④	Qty. (1)	Hex nut 1/2-13	⑨	Qty. (2)	Hex nuts 7/16-14
⑤	Qty. (1)	Carriage bolt 7/16-14 X 1.75 GR5	⑩	Qty. (1)	Carriage bolt 7/16-14 X 1.50 GR5

Note: sort hardware prior to hitch installation to confirm 1/2" & 7/16" conical washer are kept with coordinated 1/2" & 7/16" bolts and bolt lengths are installed in proper locations.

- Lower exhaust at the rubber isolator. Spraying a lubricant or soapy water on the metal hanger rod and the rubber isolator helps removal.
- Remove the rubber plug from the hole on the driver side frame rail.
- Remove rearward m6 bolt holding heat shield in place. Return to owner. Trim heat shield for access to hole on passenger frame rail. Fig 4
- Enlarge holes on both frame rails as shown Fig 2. Note: scrape undercoating and caulking from bottom of frame rails large enough to allow the hitch brackets to sit flush against the frame rails.
- Install 7/16 carriage bolts using the reverse pull wire procedure as seen in Fig 3. Leave pull wires attached. Note: length of bolts. Item 5 driver side, Item 10 passenger side.
- Install the 1/2 carriage bolt and spacer as shown in Fig 1. to the tie down hook.
- Apply the clear galvanic isolators to the passenger side bracket as shown. Fig 1
- Feed the pull wires through the slots on the hitch brackets.
- Raise the hitch into position and install 1/2 carriage bolt to the vehicles tie down hook, do not tighten down at this point. Fig 1.
- Feed the 7/16 fasteners through slots on both sides remove pullwires and install fasteners as shown Fig 1. Note: on passenger side sandwich the heat shield between the frame rail and the hitch.
- Center the hitch on the vehicle.
- Torque all fasteners to specifications shown below.
- Reinstall exhaust.

Tighten all 7/16-14 GR5 fasteners with torque wrench to 50 Lb.-Ft. (68 N*M)

Tighten all 1/2-13 GR5 fasteners with torque wrench to 75 Lb.-Ft. (102 N*M)

Note: check hitch frequently, making sure all fasteners and ball are properly tightened. If hitch is removed, plug all holes in trunk pan or other body panels to prevent entry of water and exhaust fumes. A hitch or ball which has been damaged should be removed and replaced. Observe safety precautions when working beneath a vehicle and wear eye protection. Do not cut access or attachment holes with a torch.

This product complies with safety specifications and requirements for connecting devices and towing systems of the state of New York, V.E.S.C. Regulation V-5 and SAE J684.