

# INSTALLATION INSTRUCTIONS

**EQUIPMENT REQUIRED:**

WIRING ACCESS LOCATION: PC3, PC4

DRILL BITS: 1/4, 7/16, 1" HOLE SAW

HITCH REQUIRES 1/2" PIN AND CLIP

WRENCHES: 13mm, 15mm, 11/16, 17mm

(TIGHTEN ALL FASTENERS WITH TORQUE WRENCH)

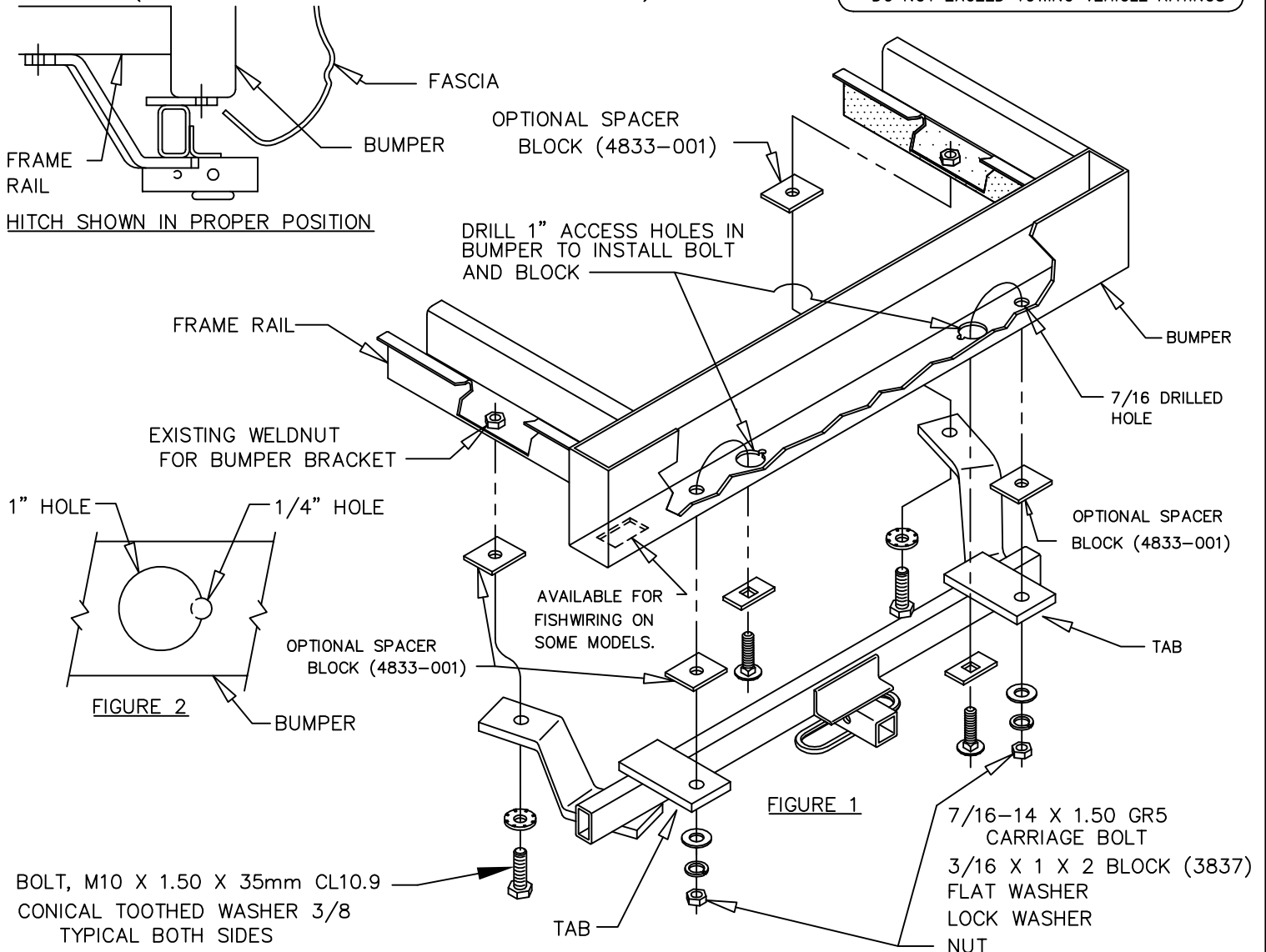

2000 LB MAX GROSS TRAILER WT  
200 LB MAX TONGUE WEIGHT  
DO NOT EXCEED TOWING VEHICLE RATINGS

BOLT, M10 X 1.50 X 35mm CL10.9  
CONICAL TOOTHED WASHER 3/8  
TYPICAL BOTH SIDES

1. REMOVE BUMPER BRACKET BOLTS FROM BOTTOM OF EACH FRAME RAIL – FASTENERS WILL NOT BE REUSED – RETURN TO VEHICLE OWNER.
2. RAISE HITCH INTO POSITION AND INSTALL M10 BOLTS AND 3/8 CONICAL WASHERS THRU HITCH INTO EXISTING WELDNUTS HAND TIGHTEN ONLY. DISCARD M10 SHIPPING NUTS.
3. DRILL A 1/4" HOLE AND A 1" ACCESS HOLE, AS SHOWN IN FIGURE 2, IN BOTTOM OF BUMPER INBOARD OF EACH TAB ON HITCH. THE 1 X 2 BLOCK WILL NOT FIT THRU THE 1" HOLE ALONE.  
NOTE: ON SOME MODELS THERE IS A RECTANGULAR HOLE THAT CAN BE USED FOR FISHWIRING AND THE 1" ACCESS HOLE WILL NOT HAVE TO BE DRILLED.
4. PUSH RECEIVER UP UNTIL HITCH TABS CONTACT BUMPER, SUPPORT WITH A JACK IF NECESSARY.
5. USING THE TABS ON THE HITCH AS GUIDES, DRILL TWO (2) 7/16" HOLES INTO THE BOTTOM OF THE BUMPER.  
NOTE: BUMPER MATERIAL IS VERY TOUGH AND DIFFICULT TO DRILL. USE 7/16 ROTABROACH HOLE CUTTING TOOL – DRAW-TITE PART NUMBER 6809 (SOLD SEPARATELY) OR CARBIDE DRILL.
6. FISHWIRE THRU EACH ACCESS HOLE A 7/16" CARRIAGE BOLT AND BLOCK. ATTACH A FLAT WASHER, LOCK WASHER AND NUT AS SHOWN IN FIGURE 1.
7. CHECK TO SEE IF RECEIVER TUBE IS LEVEL. VARIATIONS IN BUMPER POSITION MAY MAKE IT NECESSARY TO ADD A SPACER (PROVIDED) EITHER BETWEEN HITCH SIDE ARM AND FRAME RAIL OR HITCH TAB AND BUMPER, TIGHTEN BOLTS.

TIGHTEN M10 CL10.9 FASTENERS TO 38 LB.-FT.

TIGHTEN 7/16 GR5 FASTENERS TO 50 LB.-FT.

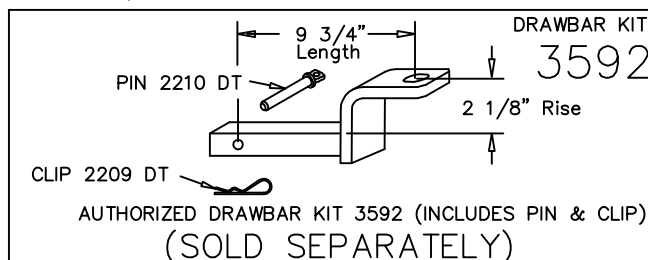

USE ONLY THE DRAWBAR SHOWN FOR CORRECT BUMPER CLEARANCE AND HEIGHT.  
DRAWBAR MUST BE USED IN THE RISE POSITION ONLY.

THIS PRODUCT COMPLIES WITH SAFETY SPECIFICATIONS AND REQUIREMENTS FOR CONNECTING DEVICES AND TOWING SYSTEMS OF THE STATE OF NEW YORK AND V.E.S.C. REGULATION V-5.

APPROX WEIGHT (LB.)	FASTENER KIT
26	K24687

NOTE: Check hitch frequently, making sure all fasteners and ball are properly tightened. If hitch is removed, plug all holes in trunk pan or other body panels to prevent entry of water and exhaust fumes. A hitch or ball which has been damaged should be removed and replaced. Observe safety precautions when working beneath a vehicle and wear eye protection. Follow car maker's specs for maximum trailer weight and tongue weight. Do not cut access or attachment holes with a torch.

**H**ORIZON  
GLOBAL