

Installation Instructions

Ford Explorer

Part Numbers:
44100

Equipment Required:

Fastener Kit: F44100

Wrenches: 3/4, 15/16, 15mm, 18mm & 21mm

Drill Bits: None

**Do Not Exceed Lower of Towing Vehicle
Manufacturer's Rating or**

Hitch type	Max Gross Trailer WT (LB)	Max Tongue WT (LB)
Weight Distributing	6000 (2724 Kg)	600 (272 Kg)
Weight Carrying Ball Mount	5000 (2270 Kg)	500 (227 Kg)

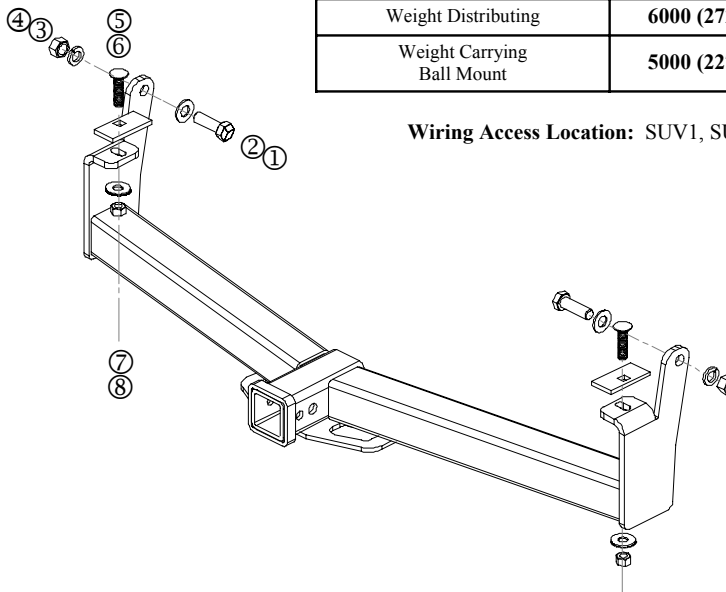

Wiring Access Location: SUV1, SUV2

①	Qty. (2)	Hex Bolt 5/8-11 X 2.00	⑤	Qty. (2)	Carriage Bolt 1/2-13 X 2.00
②	Qty. (2)	Flat Washer 5/8	⑥	Qty. (2)	Block
③	Qty. (2)	Lock Washer 5/8	⑦	Qty. (2)	Conical Washer 1/2
④	Qty. (2)	Hex Nut 5/8-11	⑧	Qty. (2)	Hex Nut 1/2-13

PRE-1997

1. Hold hitch up to the frame and align 5/8" holes in the side of the frame. Using the 1/2" holes in the flange mark the frame and drill 1/2" holes.
2. Install 5/8" bolt, flat washer, lock washer, and nut in forward holes. Install 1/2" bolt through bolt plate and insert through the frame and install 1/2" conical washer and nut.
3. Torque 5/8" nuts to 100 LB-FT. (136 N*M).
Torque 1/2" nuts to 75 LB-FT. (102 N*M).

1997-CURRENT

NOTE: Sport versions will need to remove the tow hook to install the hitch.

1. Hold hitch up to the frame and install 5/8" bolt, flat washer, lock washer, and nut in forward holes in the side of the frame. Install 1/2" bolt through bolt plate and insert through the frame and install 1/2" conical washer and nut. See diagram on the other side.
2. Torque 5/8" nuts to 100 LB-FT. (136 N*M).
Torque 1/2" nuts to 75 LB-FT. (102 N*M).

Note: check hitch frequently, making sure all fasteners and ball are properly tightened. If hitch is removed, plug all holes in trunk pan or other body panels to prevent entry of water and exhaust fumes. A hitch or ball which has been damaged should be removed and replaced. Observe safety precautions when working beneath a vehicle and wear eye protection. Do not cut access or attachment holes with a torch.

This product complies with safety specifications and requirements for connecting devices and towing systems of the state of New York, V.E.S.C. Regulation V-5 and SAE J684.