

INSTALLATION INSTRUCTIONS

VEHICLE

MITSUBISHI ENDEAVOR

EQUIPMENT REQUIRED:

WIRING ACCESS LOCATION: SUV1 & SUV 2

DRILL BITS: NONE

HITCH REQUIRES 5/8" PIN AND CLIP IF STABILIZING PIN IS NOT INSTALLED.

WRENCHES: (TIGHTEN ALL FASTENERS WITH TORQUE WRENCH) 12MM, 17MM, AND (2) 13MM

DO NOT EXCEED LOWER OF TOWING VEHICLE MFR'S RATINGS OR

HITCH TYPE ▼	MAX GROSS TRLR WT(LB)	MAX TONGUE WT(LB)
WEIGHT DISTRIBUTING	5000	500
WEIGHT CARRYING BALL MOUNT	3500	350

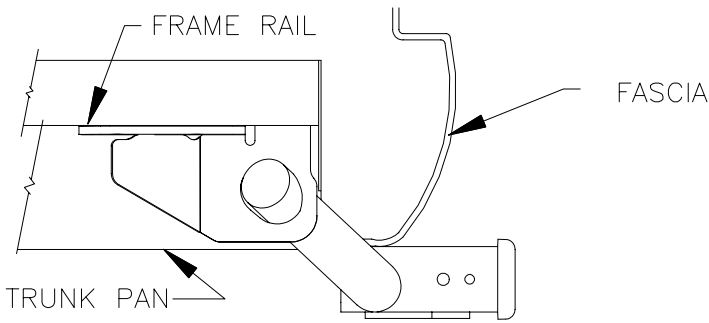

HITCH SHOWN IN PROPER POSITION

OPTIONAL LOCKING STABILIZING PIN

J-PIN

(Order Separately)

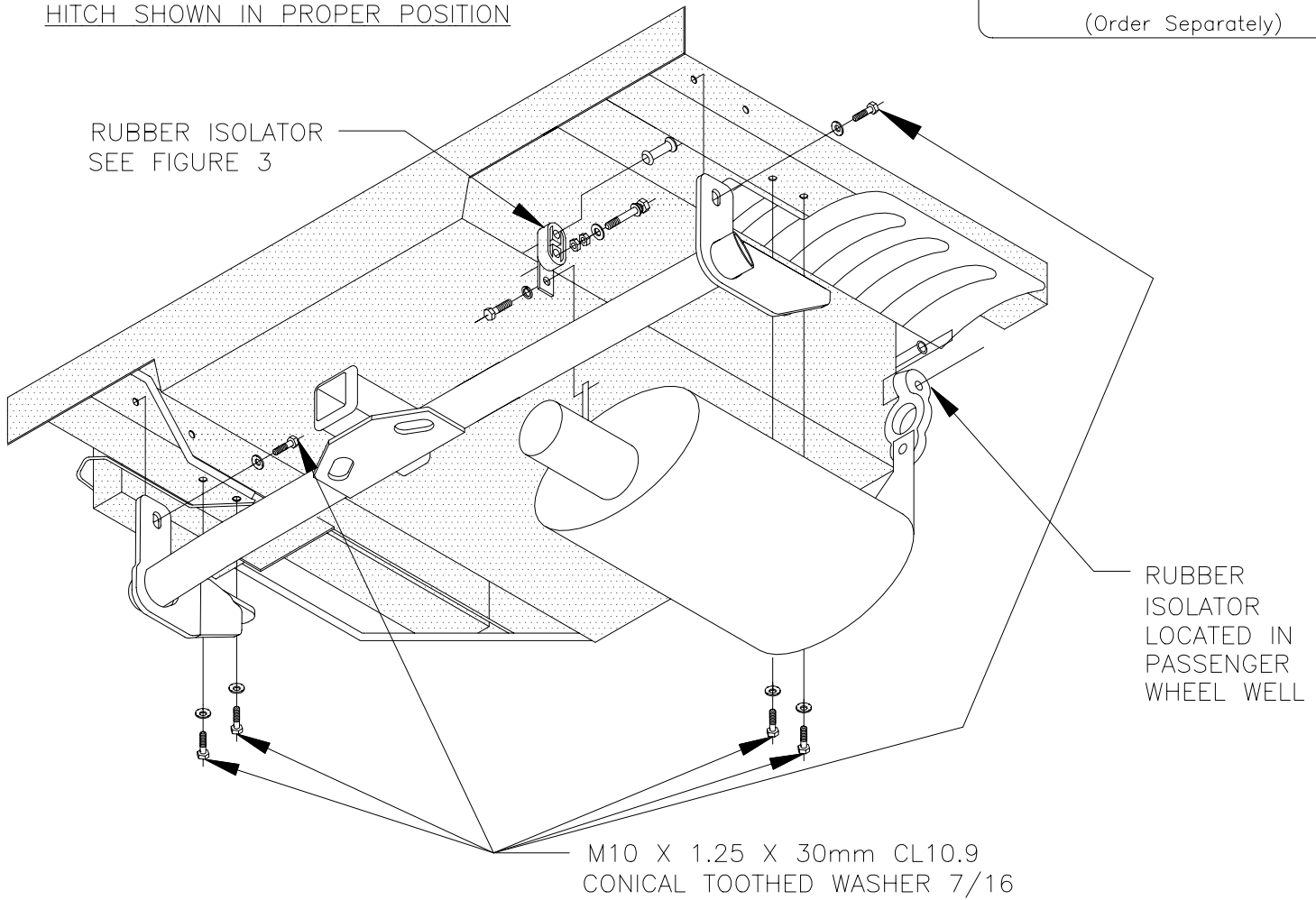

FIGURE 1

THIS PRODUCT COMPLIES WITH SAFETY SPECIFICATIONS AND REQUIREMENTS FOR CONNECTING DEVICES AND TOWING SYSTEMS OF THE STATE OF NEW YORK, V.E.S.C. REGULATION V-5 AND SAE J684.

APPROX WEIGHT (LB.)	FASTENER KIT
27	F75163

NOTE: Check hitch frequently, making sure all fasteners and ball are properly tightened. If hitch is removed, plug all holes in trunk pan or other body panels to prevent entry of water and exhaust fumes. A hitch or ball which has been damaged should be removed and replaced. Observe safety precautions when working beneath a vehicle and wear eye protection. Follow car maker's specs for maximum trailer weight and tongue weight. Do not cut access or attachment holes with a torch.

TOWING PRODUCTS
Plymouth, Michigan

VEHICLE

MITSUBISHI ENDEAVOR

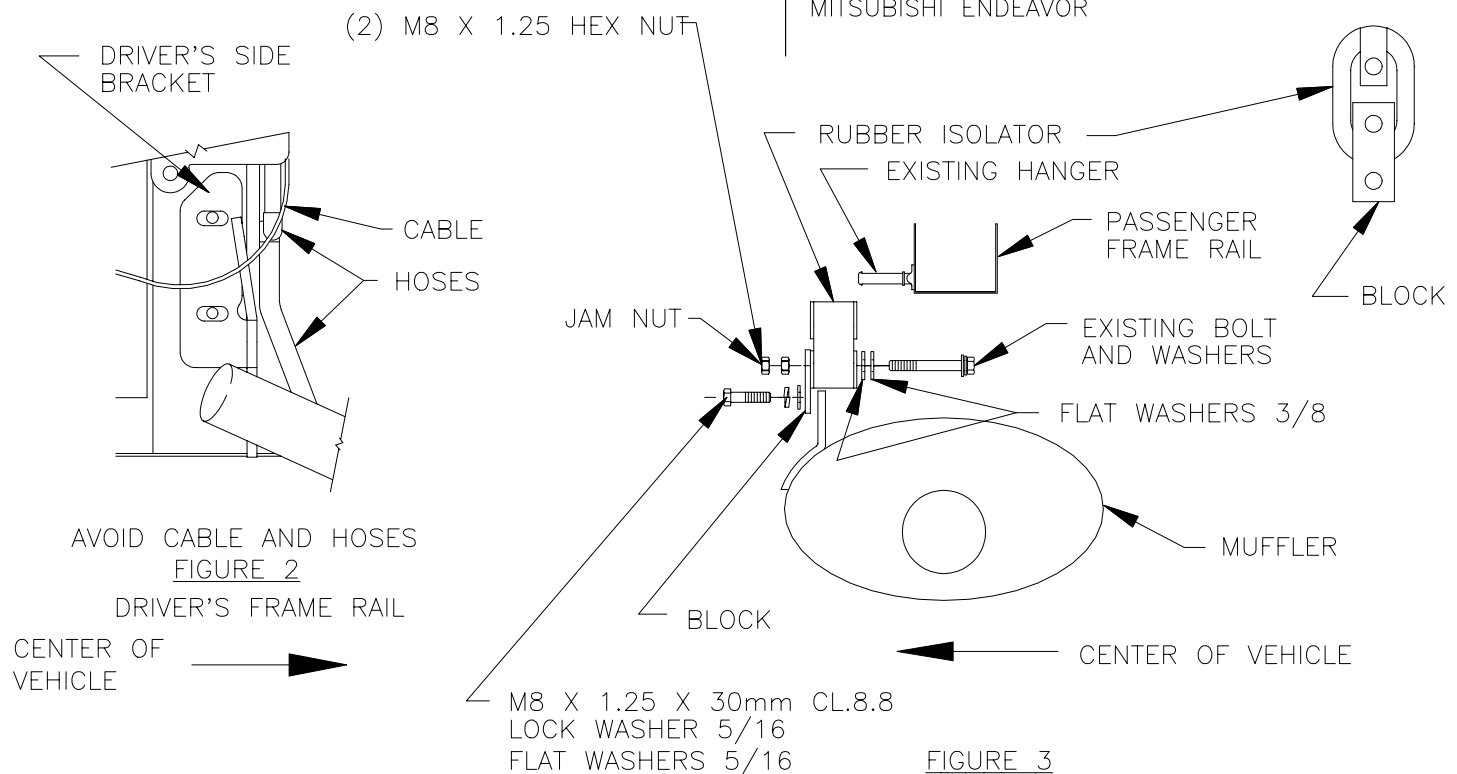

FIGURE 3

1. DETACH THE RUBBER ISOLATOR FROM THE FRONT EXHAUST HANGER LOCATED IN THE REAR PASSENGER WHEEL WELL.
2. DETACH THE RUBBER ISOLATOR FROM REAR EXHAUST HANGER BRACKET AND REMOVE M8 BOLT FROM THE MUFFLER. (SET ASIDE FOR FURTHER INSTRUCTIONS).
3. SWING HITCH OVER THE TOP OF THE MUFFLER AND OUTSIDE OF THE FRAME RAIL.
4. TILT THE HITCH REARWARD AIMING THE RECEIVER DOWNWARD AND MOVE THE DRIVER SIDE BRACKET INTO POSITION ON THE INSIDE OF THE FRAME RAIL. (TAKE CARE TO AVOID THE CABLE AND THE CARBON CANISTER HOSES.) SEE FIGURE 2.
5. ATTACH (6) M10 X 1.25X30mm CL10.9 AND (6) 7/16" CONICAL TOOTHED WASHERS INTO EXISTING WELDNUTS.
TIGHTEN ALL M10 CL.10.9 FASTENER TO 53 LB.-FT.
6. REMOVE THE METAL SLEEVE FROM THE REAR RUBBER ISOLATOR.
7. USING THE EXISTING BOLT AND WASHERS ADD THE (2) 3/8" FLAT WASHER TO THE BOLT AND THRU THE RUBBER ISOLATOR. ATTACH THE BLOCK ON THE OPPOSITE SIDE AND USING ONE OF THE M8 NUT TIGHTEN THE BLOCK TO THE RUBBER ISOLATOR AS SHOWN FIGURE 3. (SLIGHTLY COMPRESSING THE RUBBER ISOLATOR.) ATTACH THE OTHER M8 NUT AND USE IT TO JAM THE TWO M8 NUTS.
8. USING THE M8 X 1.25 BOLT, 5/16 LOCK WASHER AND 5/16 FLAT WASHER TIGHTEN THE BLOCK WITH RUBBER ISOLATOR TO THE THREADED HANGER ON THE MUFFLER POSITIONING THE BLOCK INBOARD ON THE VEHICLE.
9. REATTACH THE RUBBER ISOLATOR AND MUFFLER INTO THE ORIGINAL POSITION.
10. REATTACH THE RUBBER ISOLATOR FROM THE FRONT EXHAUST HANGER LOCATED BEHIND THE REAR PASSENGER WHEEL WELL.

THIS PRODUCT COMPLIES WITH SAFETY SPECIFICATIONS AND REQUIREMENTS FOR CONNECTING DEVICES AND TOWING SYSTEMS OF THE STATE OF NEW YORK, V.E.S.C. REGULATION V-5 AND SAE J684.

APPROX WEIGHT (LB.)	FASTENER KIT
27	F75163

NOTE: Check hitch frequently, making sure all fasteners and ball are properly tightened. If hitch is removed, plug all holes in trunk pan or other body panels to prevent entry of water and exhaust fumes. A hitch or ball which has been damaged should be removed and replaced. Observe safety precautions when working beneath a vehicle and wear eye protection. Follow car maker's specs for maximum trailer weight and tongue weight. Do not cut access or attachment holes with a torch.

TOWING PRODUCTS
Plymouth, Michigan