

FJ2

2 Ton Trolley Floor Jack Assembly & Operating Instructions



READ ALL INSTRUCTIONS AND WARNINGS BEFORE USING THIS PRODUCT.

This manual provides important information on proper operation & maintenance. Every effort has been made to ensure the accuracy of this manual. These instructions are not meant to cover every possible condition and situation that may occur. We reserve the right to change this product at any time without prior notice.

IF THERE IS ANY QUESTION ABOUT A CONDITION BEING SAFE OR UNSAFE, DO NOT OPERATE THIS PRODUCT!

HAVE QUESTIONS OR PROBLEMS? DO NOT RETURN THIS PRODUCT TO THE RETAILER - CONTACT BUFFALO TOOLS.

If you experience a problem or need parts for this product, visit our website <http://www.buffalotools.com> or call our customer help line at **1-888-287-6981, Monday-Friday, 8 AM - 4 PM Central Time**. A copy of the sales receipt is required.

FOR CONSUMER USE ONLY - NOT FOR PROFESSIONAL USE.

KEEP THIS MANUAL, SALES RECEIPT & APPLICABLE WARRANTY FOR FUTURE REFERENCE.

TABLE OF CONTENTS

RECOGNIZE SAFETY SYMBOLS, WORDS AND LABELS	2
GENERAL PRODUCT SPECIFICATIONS	2
PACKAGE CONTENTS	2
ASSEMBLY	3
OPERATION	4
MAINTENANCE	5
TROUBLESHOOTING	6

RECOGNIZE SAFETY SYMBOLS, WORDS AND LABELS

What You Need to Know About Safety Instructions

Warning and Important Safety Instructions appearing in this manual are not meant to cover all possible conditions and situations that may occur. Common sense, caution and care must be exercised when assembling or using this product.

⚠ WARNING This is a safety alert symbol. It is used to alert you to potential personal injury hazards. Obey all safety messages that follow this symbol to avoid possible injury or death.

GENERAL PRODUCT SPECIFICATIONS

Lift Cars, Pick-Ups, RV's & SUV's Up To 4,000 Lbs Max. Capacity

Minimum Height Requirement: 5"

Maximum Lift: 12"

Quick Release Valve

360° Swivel Saddle

15" Wheel Base

Heavy Gauge Reinforced Steel Frames

Two Rear 360° Swivel Ball Bearing Caster Wheels For Easy Maneuverability

PACKAGE CONTENTS

- Floor Jack
- Handle

PARTS LIST

- 1 Spindle
- 2 Tension Spring
- 3 Hydraulic Unit Assembly
- 4 Caster Wheel
- 5 Lift Arm Assembly
- 6 Side Member Assembly Right
- 7 Front Wheel
- 8 Saddle
- 9 Cover Plate
- 10 Handle Base Assembly

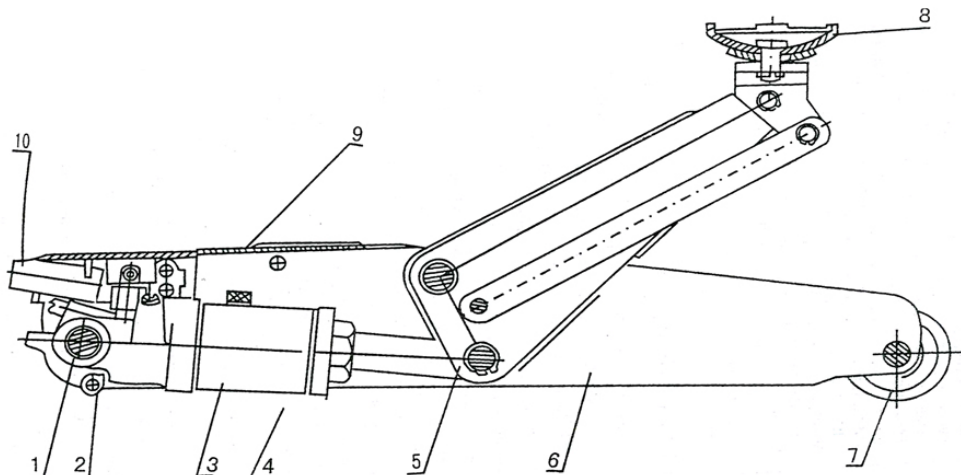

⚠ WARNING

Keep your work area clean and well lit. Cluttered and dark work areas may cause accidents or injury.

Keep bystanders, children and visitors away while operating the tool. Distractions can cause you to lose control.

⚠ CAUTION

Do not force tool. Use the correct tool for your application. The correct tool will do the job better and safer at the rate for which it is designed.

Store idle tools out of reach of children and other untrained persons. Tools are dangerous in the hands of untrained users.

⚠ WARNING

All work areas should be clean and well lit. Accidents are more likely to occur in poorly lit and cluttered areas.

⚠ WARNING

Keep children, and other distractions at a distance while operating tools.

⚠ WARNING

Use common sense while operating this power tool.

Do not use this tool if you are:

- Feeling tired or are under the influence of alcohol or drugs.
- Wearing loose clothing or jewelry. Keep long hair pulled back and away from moving parts.
- Overreaching or have improper footing. Handling the tool in this way could cause serious injury.

ASSEMBLY

⚠ WARNING

This is a lifting device only. Do not use it for anything other than it's intended purpose. Load must be supported by proper rated capacity jack stands under the vehicle before starting inspection or work. Do not overload. Jack capacity is 2 tons.

⚠ WARNING

Never stand or place your body beneath the load being lifted.

Never attempt to exceed the limits of the floor jack. Applying excessive force to the tool can overload the jack, decrease the life and increase the wear on the jack.

BEFORE USE

During shipment or handling, air in jack can become trapped in the hydraulic system, causing jack to malfunction. To release air from the hydraulic system:

1. Turn release valve counter-clockwise with handle no more than two full turns.
2. Remove oil fill plug.
3. Pump jack handle quickly in several full strokes.
4. Repeat above steps as needed. Remember to replace oil fill plug.

ASSEMBLY (CONTINUED)

WARNING

Place Floor Jack under the vehicle before starting inspection or work. Do not overload. This jack is designed for use on hard level surfaces. If used on surfaces other than hard surfaces, jack instability and possible loss of load can result.

1. Insert Handle into Jack Assembly in the front section of the Jack.
2. When this jack leaves the factory for shipment, the vent plug on top of the oil chamber is closed to prevent the oil from being spilled. The coil chamber contains the correct amount of oil before shipment. Before using for the first time, remove cover-plate, unscrew vent plug until there is 1/16" gap. If oil spill is evident, or if vent plug was found open, it is necessary to check oil level before pumping.
3. With release valve open, pump handle about 6 full strokes to assure complete distribution of oil.
4. Close release valve and jack is ready to use.
5. Always center the load on saddle of jack. Off-center loads and loads lifted while jack is not sitting level may damage the jack.

OPERATION

1. With one end of jack handle, close release valve tightly by turning it clockwise.
2. Place vehicle in Park (in gear on standard transmissions) and apply emergency brake.
3. Place jack under vehicle at proper lifting location. (Refer to owners manual). If needed, turn extension screw on jack counter-clockwise until it comes in contact with vehicle.
4. Insert jack handle into handle socket. Pump the handle to lift vehicle to desired height.

To Lower:

1. Remove handle, use small end to slowly open release valve. To open, turn slowly in counter-clockwise direction.
2. When vehicle fully lowered, remove jack. If extension screw has been extended, turn it clockwise until it retracts enough to remove from vehicle.
3. When jack has been removed from vehicle, close release valve for storage.

MAINTENANCE

CAUTION

Some chemicals can damage the product. Do not use harsh chemicals such as gasoline, carbon tetrachloride, paint thinner, etc. to clean this product.

CAUTION

A qualified repair technician must perform any tool service or repair. Service or maintenance performed by unqualified personnel could result in injury. Use only identical replacement parts. Use of unauthorized parts or failure to follow maintenance instructions may create a risk of electric shock or injury.

1. When jack is not in use, lifting arm and pump lever should be in full down position. This will protect precision, machined surfaces of the ram and the piston from corrosion.
2. Container is filled with 7 fl. oz. Hydraulic jack oil.
3. Keep clean and well lubricated, as well as the outside moving parts such as the lifting arm spindle, wheel bearings and cross head pin.
4. Should any other parts be required, please refer to the sectional drawings and quote appropriate serial number of jack when ordering.
5. **ADDING OIL:** With ram fully lowered and jack on level ground, remove oil fill plug. Add oil if level is more than $\frac{1}{2}$ " below hole. Replace cover plate.
6. **REPLACING OIL:** Oil should be replaced at least once every year. To drain oil, remove cover plate, oil filter plug and release valve. Do not allow dirt or foreign matter into system.
7. **LUBRICATION:** Put grease in fitting on base and lubricate lifting arm spindle with oil every 3 months.
8. **RUST PREVENTION:** With an oily cloth, clean and wipe the piston ram and pump piston every 3 months or when signs of rust or corrosion appear. When not in use, always leave the saddle and pump piston in the down position.

ACCESSORIES

Use only accessories that are recommended by the manufacturer for your model. Accessories that may be suitable for one tool may become hazardous when used on another tool.

TROUBLESHOOTING

If Jack Will Not Lower Or Raise Load, check the following

1. Make sure jack is on level surface. Make sure oil level is properly added. Open release valve and step on saddle. Force it to lower as rapidly as possible. Repeat this operation three or four times. This procedure will thoroughly flush the valves and assure complete distribution of oil.
2. The jack may have air trapped in the system. Open release valve. Pump handle 6 full strokes. Close release valve and try again.
3. O-ring seat for pump may be worn. This will happen only after months of service. A new o-ring seal or a complete new piston can be purchased and installed.
4. Release valve may be held open by dirt on seat. Flush by pulling lifting arm up and down several times while release valve is open. If necessary, the release valve may be removed for cleaning the valve and valve seat.

If Jack Lowers Under Load, check the following

1. The discharge valve may be held open by dirt on ball seat. When a dirty discharge valve or ball seat exists, the jack may lower quickly, causing handle to fly back with force. This is caused by the oil rushing back into the pump chamber and through the open ball seat. When this happens, it is advisable to repeat procedure 1 before going through the partial disassembly of the hydraulic unit. The discharge valve is located at the bottom of ram cylinder. There is a screen washer which must be removed carefully. Remove the valve ball and clean the valve seat. Wipe ball and replace and reseat. Use 1 / 4 " diameter X3 long punch and small hammer. Place punch on top of ball and give the punch a light tap. This will have the effect of reseating the ball on its seat. Install the screen washer. Screw in ram cylinder tightly. Replace washers top and bottom of oil chamber. Install ram assembly and screw in top nut.
2. Cup seat for the ram may be worn. This is likely only in jacks that have given very heavy service. Follow above procedure until access to ram assembly is made. Remove worn seal by pulling away or cutting with a small knife. Take caution not to damage the new ram seal when installing.

If Jack Will Not Lower Completely When Raised, check the following

1. Return spring for lifting arm may be broken or unhooked. Replace return spring.
2. It may need lubrication. Clean and oil all moving parts in the lifting arm mechanism.
3. Hydraulic unit may contain too much oil and vent valve may be closed. Open vent plug.

If Jack Will Not Lift Full 2 Ton Capacity, check the following

1. The o-ring seal for piston pump may be worn.
2. The unit may have air trapped in the system.
3. The overload valve is factory adjusted for the jack to lift 2 tons load and should not be altered.