

swisherinc.com

OWNER'S MANUAL

MODEL NO.

STARTING SERIAL #:
L118-236001

RC14552CPKA

RC14552CPKA-CA

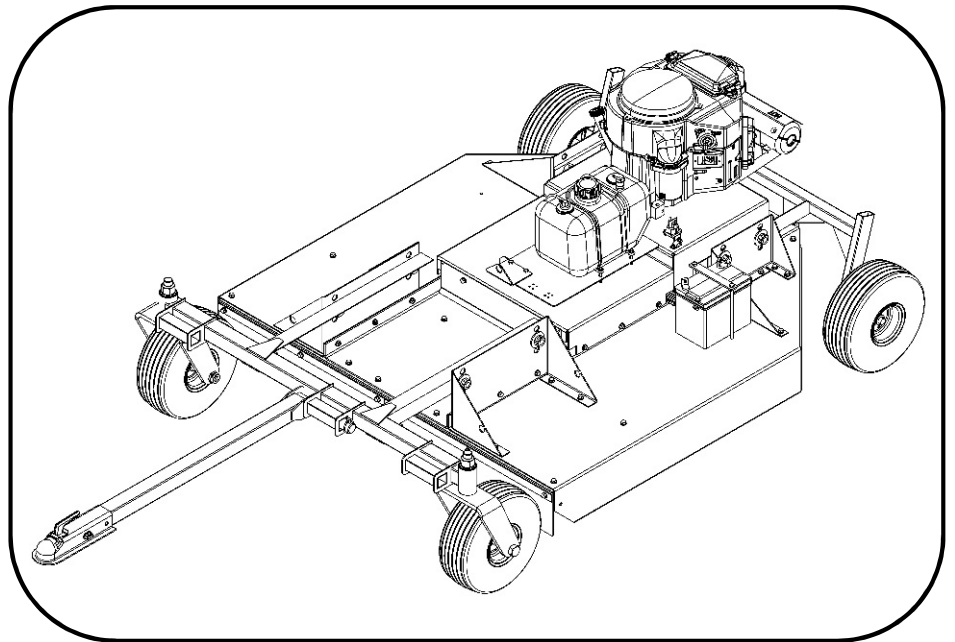

COMMERCIAL PRO 52" COUNTRY CUT TRAIL CUTTER



IMPORTANT

Read and follow all
Safety Precautions
and Instructions
before operating this
equipment.

**Assembly
Operation
Service and Adjustment
Repair Parts**

SWISHER[®]

7/30/2020

SWISHER ACQUISITION INC.
1602 CORPORATE DRIVE, WARRENSBURG, MISSOURI 64093
PHONE (660) 747-8183 FAX (660) 747-8650

Made In The
USA
of US and Global Parts

LIMITED WARRANTY

The manufacturer's warranty to the original consumer purchaser is: This product is free from defects in materials and workmanship for the period's shown below beginning from the date of purchase by the original consumer purchaser. We will repair or replace, at our discretion, parts found to be defective due to materials or workmanship. This warranty is subject to the following limitations and exclusions:

As required by CFR § 1060.120, the fuel system related components, which have been certified to this equipment by SAI are to be free of defects in material and workmanship for a period of two (2) years from the date of purchase by the original consumer purchaser.

- 1) Engine Warranty All engines utilized on our products have a separate warranty extended to them by the individual engine manufacturer. Any engine service warranty is the responsibility of the engine manufacturer and in no way is Swisher or its agents responsible for the engine warranty. The Kawasaki Engine Service Hotline is 1-877-364-6404 or email kawpower-website@kmc-usa.com

- 2) Commercial Use This product has a 1yr Limited Commercial - 2 Year Limited Consumer on All Non-Engine Parts from the date of purchase.

- 3) Limitations This warranty applies only to products, which have been properly assembled, adjusted, and operated in accordance with the instructions contained within this manual. This warranty does not apply to any product of Swisher that has been subject to alteration, misuse, abuse, improper assembly or installation, shipping damage, or to normal wear of the product.

- 4) Exclusions Excluded from this warranty are normal wear, normal adjustments, and normal maintenance.

In the event you have a claim under this warranty, you must return the product to an authorized service dealer. All transportation charges, damage, or loss incurred during transportation of parts submitted for replacement or repair under this warranty shall be borne by the purchaser. Should you have any questions concerning this warranty, please contact us toll-free at 1-800-222-8183. The model number, serial number, date of purchase, and the name of the authorized Swisher dealer from whom you purchased the mower will be needed before any warranty claim can be processed.

THIS WARRANTY DOES NOT APPLY TO ANY INCIDENTAL OR CONSEQUENTIAL DAMAGES AND ANY IMPLIED WARRANTIES ARE LIMITED TO THE SAME TIME PERIODS STATED HEREIN FOR ALL EXPRESSED WARRANTIES. Some states do not allow the limitation of consequential damages or limitations on how long an implied warranty may last, so the above limitations or exclusions may not apply to you. This warranty gives you specific legal rights and you may have other rights, which vary from state-to-state. This is a limited warranty as defined by the Magnuson-Moss Act of 1975.

Thank you for choosing Swisher's 52" Trail Cutter. Before operating your cutter, please read, understand and follow all of the safety precautions and other instructions explained in this manual. As with all power equipment, lawn mowers, and cutters can be potentially dangerous if improperly used.

SAFETY PRECAUTIONS



This Safety Alert Symbol indicates important messages in this manual. When you see this symbol, carefully read the message that follows and be alert to the possibility of personal injury.

Read this manual completely. This machine can amputate hands and feet, and throw objects. Failure to observe the following safety instructions could result in serious injury or death.

- Read the manual. Learn to operate this machine safely.
- Always disconnect the spark plug wire and place the wire where it cannot contact the spark plug, to prevent accidental starting the engine when setting up, transporting, adjusting or making repairs.
- Keep all shields and guards in place.
- Understand the speed, steering and stability of this machine. Know the positions and operations of all controls before you operate this machine. Check all of the controls in a safe area before starting to work with this machine.
- Allow only responsible adults who are familiar with these instructions to operate this machine. **Never allow children to operate this machine.**
- Clear the area of objects such as rocks, toys, wire, etc. that can be picked up and thrown by the blade.
- Be sure the area is clear of other people before mowing. Be aware of the cutters discharge direction and do not point at anyone. **Stop the machine** if anyone enters the cutting area. Children are often attracted to the machine and the mowing activity. ***Never assume that children will remain where you last saw them.*** Keep children under the watchful care of another responsible adult.
- **No riders!**
- Do not put hands or feet near or under rotating parts.
- Do not mow in reverse. **Always look down and behind before and during backing.**

- Turn off the blades when not cutting. Before leaving the machine, turn off the blades and stop the engine.
- Watch for traffic when operating near or crossing roadways.
- Do not operate the cutter if it has been dropped or damaged in any manner or if the mower vibrates excessively. Excessive vibration is an indication of damage. Repair cutter as necessary.
- Dress properly. Do not operate the cutter when barefoot or wearing open sandals. Wear only solid shoes with good traction when cutting.
- Never allow operation by untrained persons.
- Do not operate the machine while under the influence of alcohol or drugs.
- Do not operate on slopes greater than 15 degrees.
- Never tamper with safety devices. Check their proper operation regularly.
- Stop and inspect the equipment if you strike an object. Repair, if necessary, before restarting. Never make adjustments or repairs with the engine running.
- Cutter blades are sharp and can cut. Wrap the blades or wear gloves, and use extra caution when servicing them. Do not operate at too fast a rate.
- The braking system is applied when the blades become disengaged. It is designed to bring the blades to a quick stop (approximately 10 seconds). Each Trailcutter brake system has been set at the factory. For safety, the consumer should not alter the braking system.

ASSEMBLY

- Disengage spark plug wire and place where it cannot make a connection.
- Attach tow bar to front of mower. Refer to Fig 2 pg 11.
- Check engine oil. All engines are filled with oil at the factory. Verify oil level and add if necessary before starting engine. (See Engine Owner's Manual)
- Verify fuel level and add if necessary before starting engine.
- A standard U1 battery is required (not included).
- Check the battery. If battery is put into service after the "month & year" of the date on the battery, then it may need to be charged with a 12 volt battery charger for a minimum of 1 hour, but no more than 2 hours at a rate of 6 to 10 amps.
- Attach battery cables to battery. Red wire to positive (FIRST) and black wire to negative (SECOND).
- Reconnect spark plug wire.
- Refer to Owner's Manual pg 5 for proper operating procedures.

OPERATING YOUR TRAIL CUTTER



The operation of any mower can produce foreign objects to be thrown into the eyes, resulting in severe eye damage. Always wear certified safety glasses or wide-vision safety goggles over spectacles before starting any cutting machine and while operating such a machine.



The operation of any cutter produces sound waves that are damaging to the human ear. Ear protection is recommended.



CAUTION! Tragic accidents can occur if the operator is not alert to the presence of children. Children are often attracted to the machine and the mowing activity. *Never assume that children will remain where you last saw them.*

INTENDED USE

The 52" Trail Cutter is designed to clear dense areas of grass and cut saplings up to 3 inch thick on meadows and small estates. **It is not intended to create a finish cut on lawns.** Your Trail Cutter should be towed behind an ATV, golf cart, lawn tractor or other approved vehicle. It is not recommended for speeds exceeding 5 MPH.

ATTACHING TRAIL CUTTER TO TOW VEHICLE

- Back vehicle up to desired towing position. Tow bar may be attached to center location or either side.
- Attach 2" ball coupler to vehicle with corresponding ball.

TRANSPORTING CUTTER

- Stop Trail Cutter.
- When transporting without the use of a tow vehicle, remove spark plug wire and place it where it cannot contact the spark plug.

STOPPING THE ENGINE

- Make sure the tow vehicle parking brake is set.
- Disengage cutting blades.
- Reduce engine to idle speed and allow engine to run momentarily for cooling.
- Turn the key to the off position.

IMPORTANT: This engine is not equipped with a spark arrester muffler. It is a violation of California Public Resource Code Section 4442 to use or operate the engine on any forest-covered, brush-covered, or grass-covered land. Other states or federal areas may have similar laws.

ENGAGING BLADES

Note: Do not attempt to start the unit with the engage switch console in the “**ENGAGED**” position.

- Engage blades by pulling out on the PTO switch.
- Push PTO switch in to disengage blades. See detail on page 16 figure – 8
- The braking system is applied when the blades become disengaged. It is designed to bring the blades to a quick stop (approximately 10 seconds). The electric clutch comes with an internal brake.

STARTING THE ENGINE

See engine manufacturer’s recommendations for the type and amount of oil and fuel used.

- Make sure the tow vehicle parking brake is set, mower is level, and blades are disengaged. Engine must be level to accurately check and fill oil. Do not overfill.
- Check spark plug wire, oil, and fuel.
- Check all electrical connections for buildup of debris.
- Set engine idle to “**CHOKER**” position.
- Turn key to the “**RUN**” position, then to the “**START**” position.
- Set engine idle at maximum RPM for best performance.
- Allow engine to run a few moments before engaging blades.



CAUTION: SHUT OFF THE CUTTER ENGINE AND REMOVE SPARK PLUG WIRE FROM SPARK PLUG BEFORE MAKING ANY ADJUSTMENTS TO THE CUTTER.

CUTTER HEIGHT ADJUSTMENT

- There is approximately 3” of height adjustment.
- The cutting height can be adjusted by raising the mowing unit onto a series of supported surfaces such as automotive style jack stands or blocks, etc. **This should not be done manually but by a power assisted hoist or floor jack.**
- Once the unit is safely supported off the ground just enough for the tires to clear the ground you can remove the attaching bolts , nuts and washers (Items # 3, 4 and 5 shown in FIG 9 on page 14).
- Once the hardware is removed you can move the axles up or down to achieve a lower or higher cut and reattach.
- Always verify that the axle hardware is tightened securely once reinstalled.

STARTING TO CUT

- Adjust the cutting height to desired height.
- Double check vehicle connection to cutter attachment.
- Start mower engine and set throttle to “FAST” for best cutting performance.
- Carefully mount tow vehicle and start mowing at a slow travel speed.

STOPPING THE CUTTING SESSION

- Bring tow vehicle to a complete stop, set the parking brake and disengage blades.
- Turn key switch to the “OFF” position.
- Always remember to remove keys to avoid irresponsible usage.

SUGGESTED CUTTING PRACTICES

- Operate cutter engine at full throttle to assure the best cutting performance and maximum material discharge.
- Allow wet grass to dry. Wet grass will clump and collect under the mowing deck.
- Cutter should be started with tow vehicle in low gear and increased only as safe mowing conditions permit. Cutting speed should not exceed 5 MPH.
- Reducing the travel speed will help cut dense growth. This allows the blades the time necessary to make its initial cut, and regain momentum to continue cutting and discharging debris properly. The engine may stall if you are mowing too fast!
- Do not attempt to cut areas that the tow vehicle cannot maneuver through and/or slopes that you do not feel comfortable riding.

CUTTER MAINTENANCE

GENERAL RECOMMENDATIONS

The warranty on this cutter does not cover items that have been subjected to operator abuse or negligence. To receive full value from the warranty, operator must maintain unit as instructed in this manual.

Some adjustments will need to be made periodically to maintain your unit properly.

BEFORE EACH SEASON

A new spark plug and clean air filter assure proper air fuel mixture and help your engine run better and last longer.

- Replace the spark plug.
- Clean or replace the air filter.
- Check blades and belts for wear.

BEFORE EACH USE

- Check engine oil level. (Do this twice to ensure an accurate reading).
- Check condition of air filter and clean or replace if necessary.
- Check blade operation.
- Check for loose fasteners.

DAILY MAINTENANCE

Make sure all nuts and bolts are tight and cotter pins and retainer springs are secure. Keep blades sharp. Observe all safety precautions.

BLADE CARE AND SERVICE

For best results cutter blades must be kept sharp. The blades can be sharpened with a few strokes of a file or grinding wheel. Do Not attempt to sharpen while on the cutter.

Important: Replace blades that have been damaged or deeply nicked.

Important: Check blade and spindle hardware on a regular basis to make sure nuts are tight.



CAUTION: DO NOT HANDLE CUTTER BLADES WITH BARE HANDS. CARELESS OR IMPROPER HANDLING MAY RESULT IN SERIOUS INJURY.

GENERAL TROUBLESHOOTING

The unit is not cutting level.

- Check for bent or broken blades
- Without the engine running, make certain blades are installed identically.

The engine will not start.

- Disengage blades, turn key switch to the “OFF” position, check battery and all other electrical connections and inspect spark plug and wire.
- Contact engine manufacturer or qualified mechanic.

Engine runs poorly.

- See engine manual.
- Check the throttle adjuster.
- Replace fuel, clean fuel filter and fuel line.
- Check spark plug and gap.

Cutter bounces excessively while towing.

- Decrease tire pressure.
- Tow at a lower speed.



IF PROBLEMS PERSIST HAVE A QUALIFIED MECHANIC SERVICE THE CUTTER. NEVER ATTEMPT TO MAKE AN ADJUSTMENT THAT YOU ARE NOT SURE IS CORRECT. DOING SO CAN CAUSE OTHER PROBLEMS.



SAFETY AND OPERATIONAL DECALS

Replace decal immediately if damaged. Order by part number from Swisher. 1-800-222-8183, 8-5 CT M-F



19976-SWISHER FLAG DECAL



OD55-DANGER DECAL



OD10-ENGAGE DECAL



OD28-OFF/RUN/START DECAL



OD29-DANGER DECAL



OD33-5MPH DECAL



OD36-Deflector Decal



OD45-WARNING DECAL



OD99112 LARGE SWISHER LOGO

FRONT SKIRT ASSEMBLY

FIGURE 1

ITEM NO.	PART NO.	DESCRIPTION
1	NB596	Bolt - Serr Flange, 5/16-18 X 3/4 Gr 5
2	NB181	Nut - Nyloc 5/16-18 ZY
3	13856*	Front Guard Support
4	13857	Front Debris Flap; RT52
5	10548	Bolt - Serr Flange, 5/16-18X1GR5 ZY
6	13861*	Clamping Plate-Front Debris Guard
7	NB170	Nut - Serr Flange 5/16-18 ZY Case Hrd
8	NB275	Washer - SAE Flat 5/16 ZY

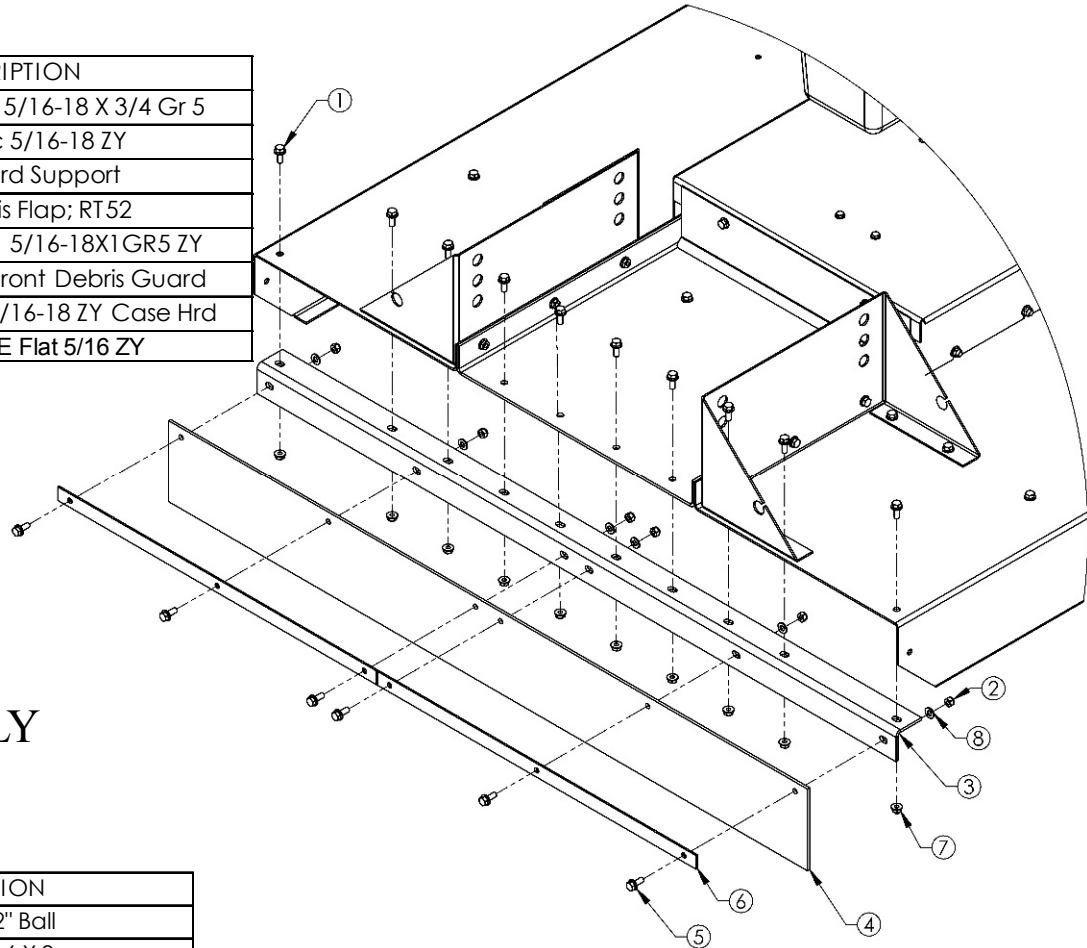

HITCH BAR ASSEMBLY

FIGURE 2

ITEM NO.	PART NO.	DESCRIPTION
1	7365	Coupler - 2" Ball
2	NB150	Bolt - 3/8-16 X 3
3	NB272	Washer - SAE Flat 3/8
4	13917*	Weldment - Hitch
5	NB182	Nut - Nyloc 3/8-16
6	18201*	Weldment - Front Axle
7	14333	Pin - Click, 5/16"

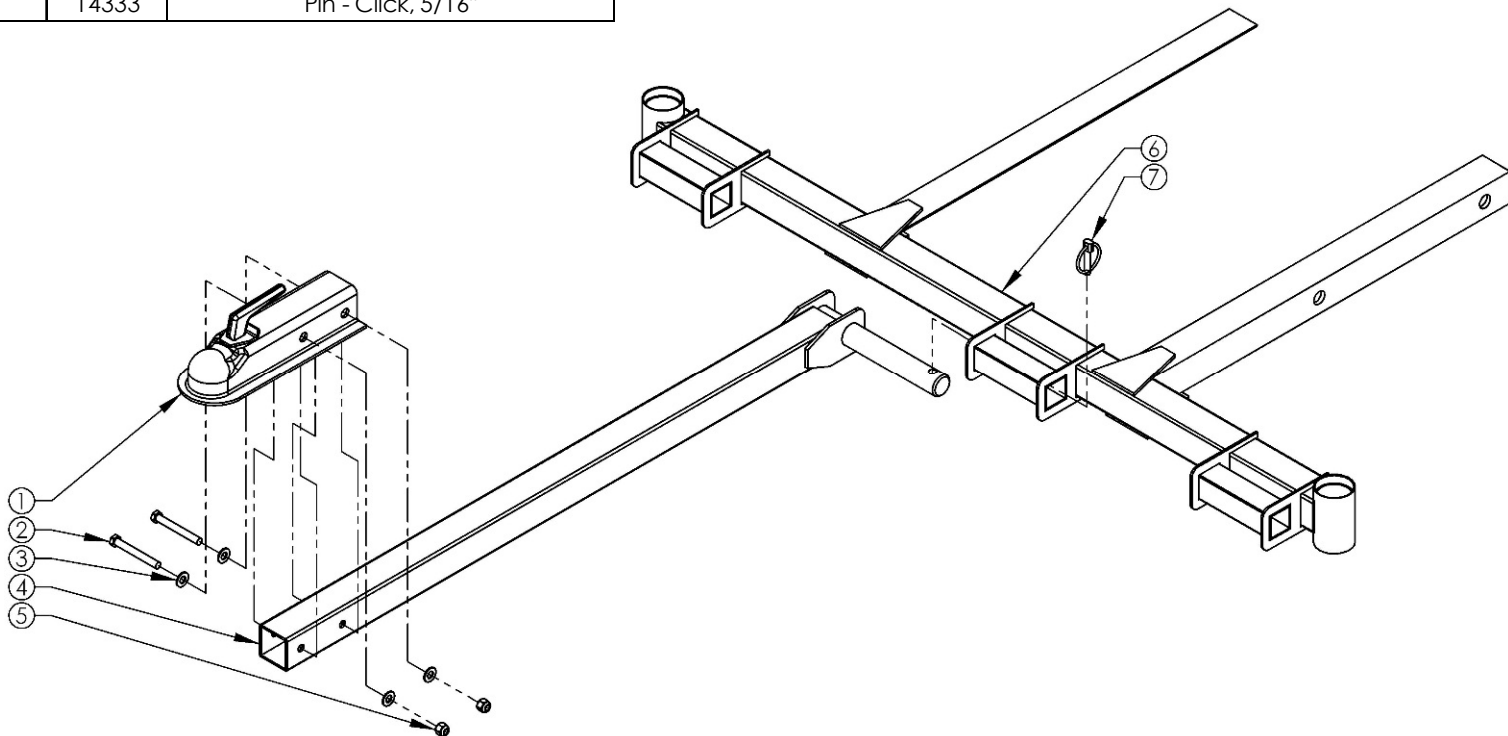

When ordering replacement parts
 * = USE PAINT CODE: TK=BLACK

GAS TANK ASSEMBLY

FIGURE 4

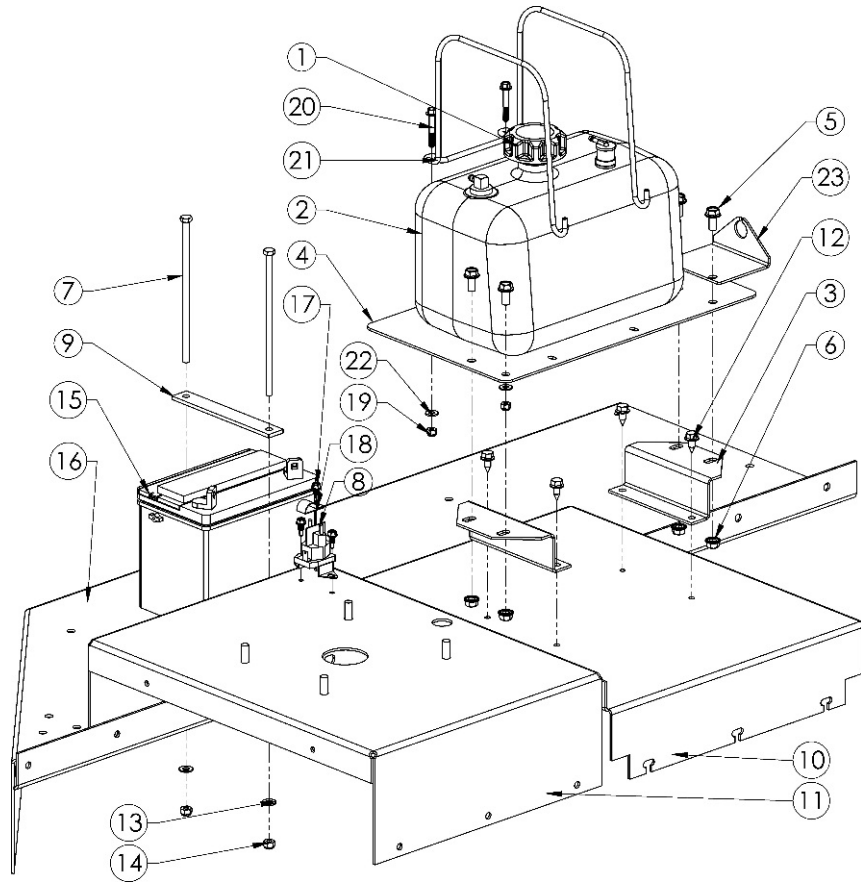

ITEM NO.	PART NO.	DESCRIPTION
1	18221	Cap, Fuel - 2.50 Gallon, Carb Sealed
2	18214	Fuel Tank - 2.5 Gallon, Carb
3	18333*	Bracket - Gas Tank, RT52
4	18331*	Mount - For EPA/CARB Gas Tank
5	NB780	Bolt - Serr Flange, ZY 3/8-16X3/4 Gr5
6	NB779	Nut - Serr Flange, Hex ZY 3/8-16
7	NB147	Bolt - 5/16-18 X 7.5 HCC GR2 ZP
8	1002004	Solenoid - 3 Pole
9	14000	Battery - Tie Down
10	13841*	Idler Cover - RT52
11	20913*	Motor Base - RT52
12	26X249	Screw - .312-18X.75
13	NB275	Washer - SAE Flat 5/16 ZY
14	NB181	Nut - Nyloc 5/16-18 ZY
15	N/A	Battery (U1R) Not Included
16	13961*	Deck - RT52, Left
17	NB161	Screw - HX Tek 14 X 3/4 ZP
18	14316	Clamp - Conduit, 3/8" x 1/4" Hole
19	NB180	Nut - Nyloc 1/4-20
20	18236	Bolt - Serr Flange 1/4-20 X 1 3/4 GR5 ZY
21	18225	Bracket - Fuel Tank
22	NB274	Washer - SAE Flat 1/4 ZY
23	20914*	Bracket - Harness, RC14552CPKA

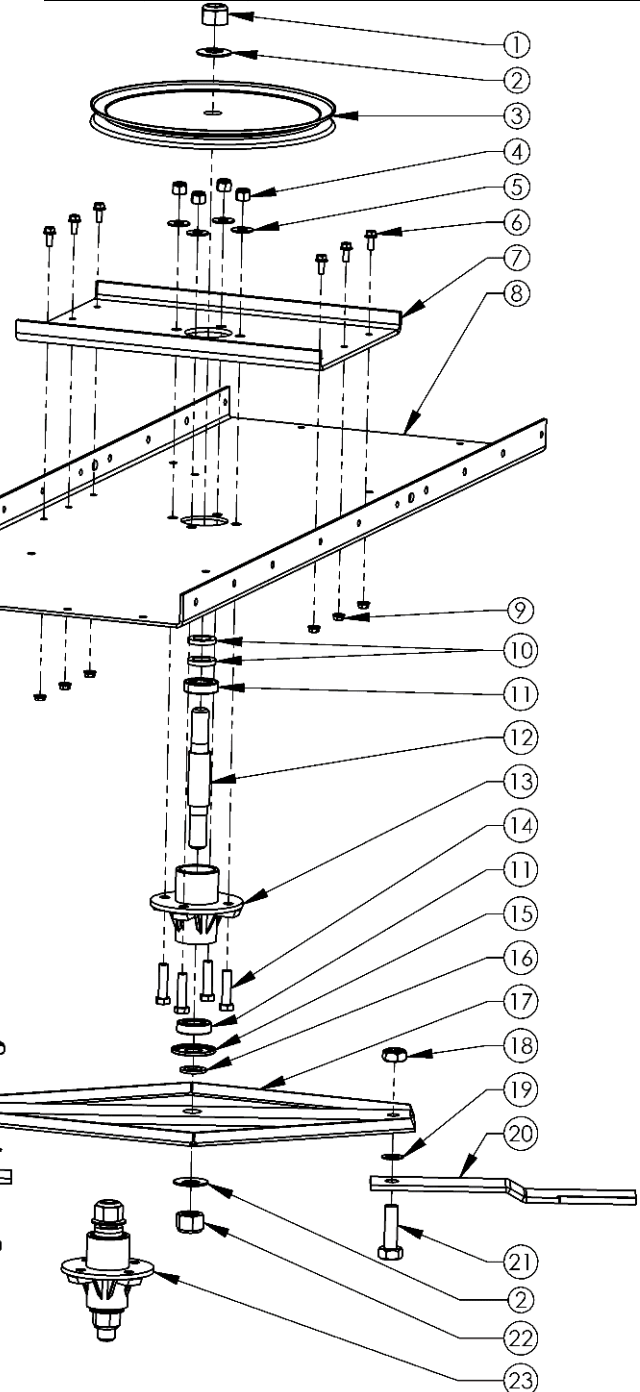

BLADE DRIVER ASSEMBLY

FIGURE 5

ITEM NO.	PART NO.	DESCRIPTION
1	NB612	Nut - Nyloc 1"-8
2	NB738	Washer - Belleville, 1 X 2
3	13863	Pulley - 14" X 1" ID
4	NB281	Nut - Nyloc 1/2-13
5	NB555	Washer - USS Flat, 1/2
6	NB596	Bolt - Serrated Flange, 5/16-18 X 3/4
7	13840*	Plate - Blade Driver Support
8	13836*	Center - Deck
9	NB170	Nut - Serrated Flange 5/16-18
10	21344	Spacer - Engine Pulley
11	4845	Bearing - Blade
12	18844	Shaft - Blade
13	4858*	Blade Driver Housing
14	NB509	Bolt - 1/2-13 X 2
15	21372	Cover - Dust (If Equipped)
16	NB614HT	Washer - 1 X 1 1/2
17	13864*	Weldment - Stump Jumper
18	NB609	Nut - 3/4-10
19	NB179	Washer - 3/4 X 1 1/4
20	10358	Blade
21	11431	Bolt - 3/4-10 X 2
22	18850	Nut - Nyloc 1"-14
23	18905	Kit - Replacement, Blade Driver

Note: The pulley, stump jumper, blades, blade hardware and housing hardware are not included with the 18905 replacement blade driver kit.

When ordering replacement parts

* = USE PAINT CODE: TK=BLACK

ENGINE, CLUTCH ASSEMBLY

FIGURE 6

ITEM NO.	PART NO.	DESCRIPTION
1	N/A	Engine (Reference Model Shown)
2	N/A	Gasket - Kawasaki Muffler
3	689S	Spacer - Short, Engine Pulley, .687
4	N/A	Washer - Split Lock, M8
5	N/A	Nut - M8 x 1.25
6	20913*	Motorbase Weldment - RT52
7	3813	Clutch - Electric
8	699	Washer - Belleville 7/16 X 1 1/4
9	NB711	Washer - Split Lock, 3/8 ZY, Medium
10	NB618	Bolt - 3/8-16 X 1 1/4 GR5 ZY
11	20919	Muffler - Kawasaki, 14.5HP FS481V
12	NB685	Bolt - 7/16-20 X 2 1/2 HCS GR5 ZP NYLOC
PARTS NOT SHOWN		
	16000	Valve - Oil Drain
	18810	Adapter - Oil Drain, Kawasaki

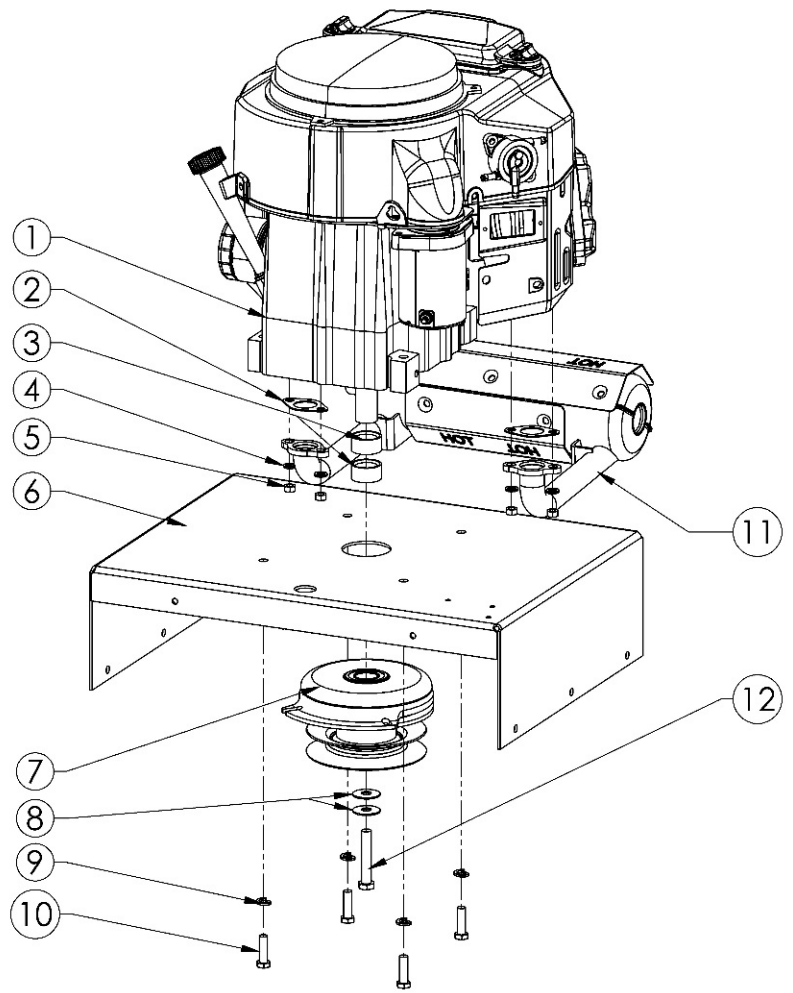

BELT ENGAGE CONFIGURATION

FIGURE 7

ITEM NO.	PART NO.	DESCRIPTION
1	B527	Pulley - Idler, OD-3.25", ID-3/8"
2	NB693	Bolt - HTC, 3/8-16 X 2 1/4 GR5 ZY
3	NB618	Bolt - 3/8-16 X 1 1/4 GR5 ZY
4	6040Z	Washer For Idler
5	13876*	Idler Arm - RC52
6	6037	Bushing - Idler
7	NB182	Nut - Nyloc 3/8-16 ZY
8	10177	Washer - Fender 3/8X1 1/2, Crbn Stl GR 2
9	3609	Spring - Tapered
10	10546	Eyebolt - Turned 3/8-16 X 5 ZY STD
11	NB280	Nut - 2 Way Lock 3/8-16 ZY&Wax Gr A
12	NB207	Nut - Jam, Nylok 3/8-16 ZY
13	NB272	Washer - SAE Flat 3/8 ZY Carbon Steel

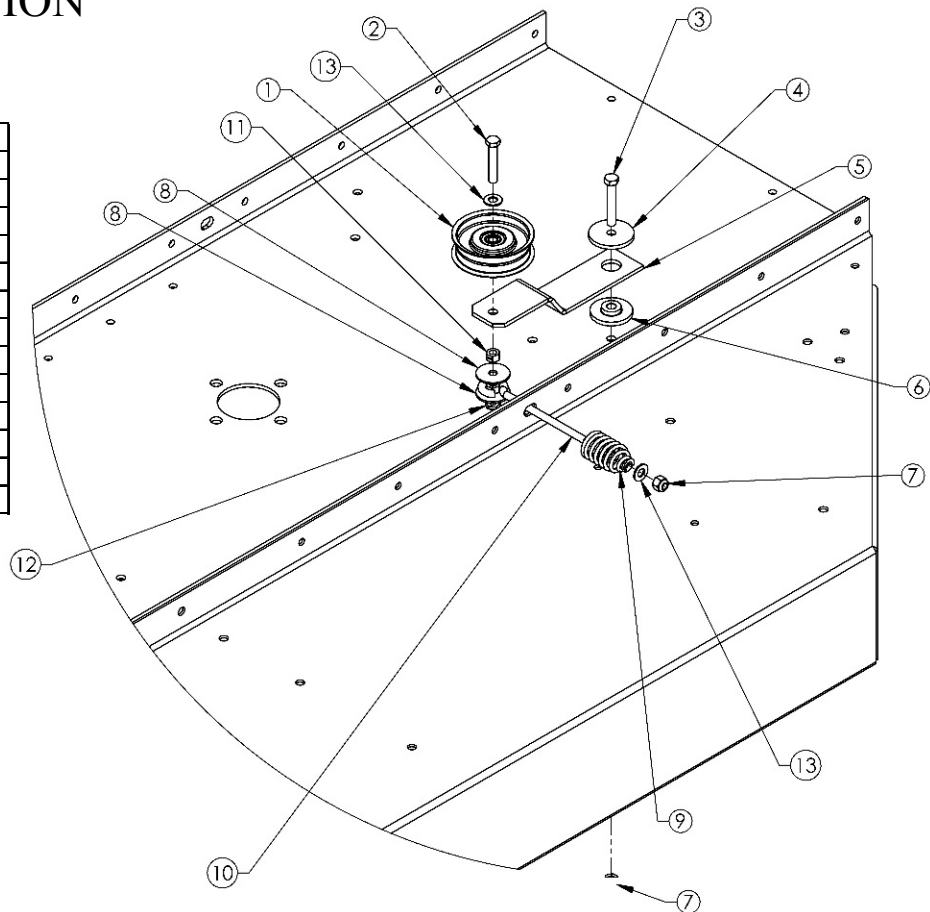

When ordering replacement parts
 * = USE PAINT CODE: TK=BLACK

COVER – GUARD ASSEMBLY

FIGURE 8

ITEM NO.	PART NO.	DESCRIPTION
1	13870*	Cover - Stump Jumper Pulley
2	26X249	Screw - .312-18 X .75
3	13841*	Idler Cover
4	20913*	Weldment - Motorbase
5	13871*	Cover - Engine Pulley
6	13961*	Weldment - Left Deck
7	NB253	Bolt - Serrated Flange, 5/16-18 X 1 1/4
8	NB170	Nut - Serrated Flange 5/16-18
9	13836*	Center Deck
10	NB596	Bolt - Serrated Flange, 5/16-18 X 3/4
11	13962*	Weldment - Right Deck

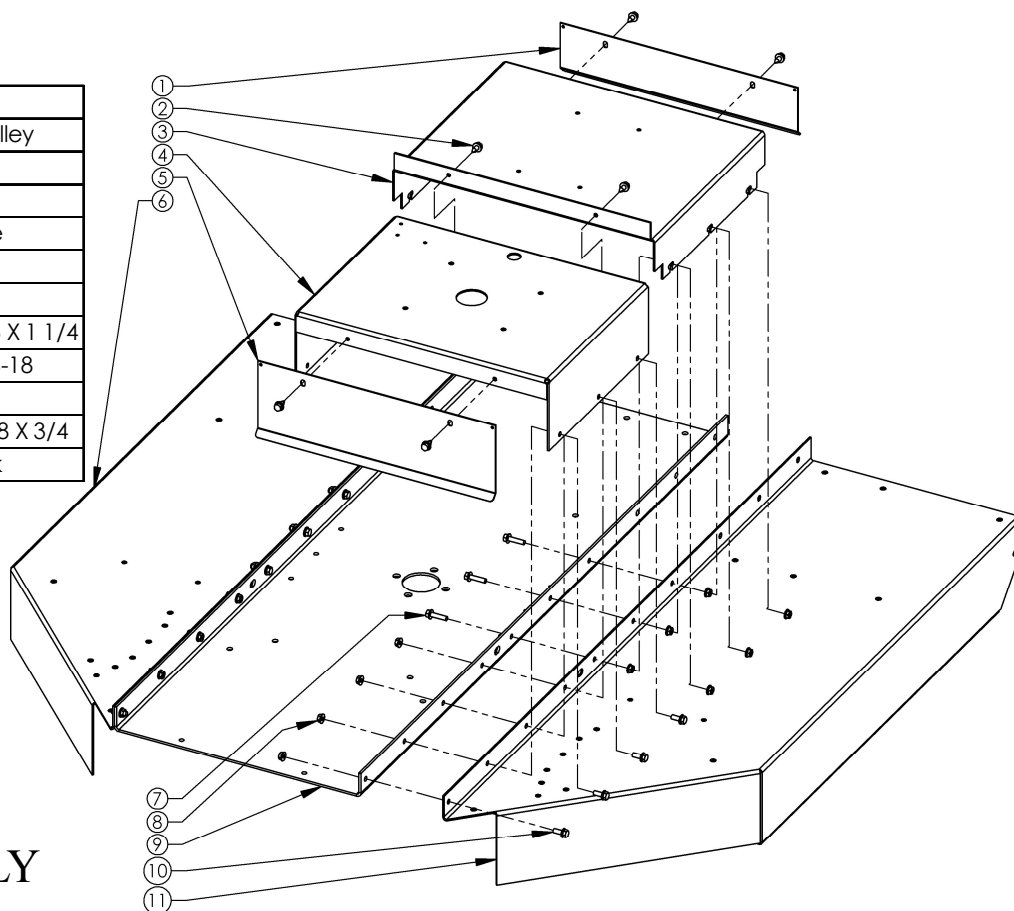

AXLE - WHEEL ASSEMBLY

FIGURE 9

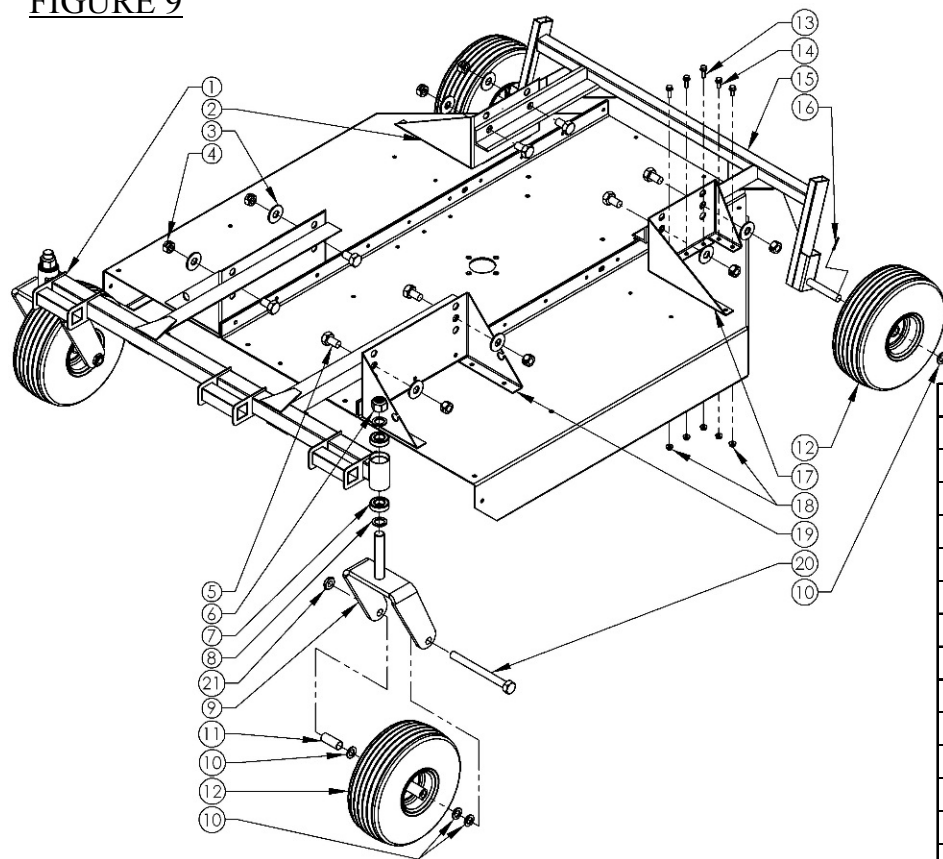

ITEM NO.	PART NO.	DESCRIPTION
1	18201*	Weldment - Front Axle
2	13843*	Rear Axle Support, Right
3	NB146	Washer - SAE 3/4
4	13997	Nut - 3/4-10; 2 Way Locking
5	13862	Bolt - 3/4-10 x 1 1/4
6	NB612	Nut - Nyloc 1"-8
7	4845	Bearing - Blade
8	NB614HT	Washer - 1 X 1 1/2 10GA
9	18841*	Caster - Weldment, HD
10	NB184Z	Washer - 3/4ID X 1 1/4OD
11	18916	Spacer - Wheel, 2.875"
12	14314K	Tire - 13/500, 3/4
13	10548	Bolt - Serrated Flange, 5/16-18 X 1
14	NB596	Bolt - Serrated Flange, 5/16-18 X 3/4
15	13845*	Rear Axle Weldment
16	NB126	Pin - Cotter, 1/8 X 1
17	13844*	Rear Axle Support, Left
18	NB170	Nut - Serrated Flange 5/16-18
19	13842*	Front Axle Support
20	NB706	Bolt - HCS 3/4-10 X 8
21	NB313	Nut - Nyloc Jam 3/4-10

AXLE SUPPORT ASSEMBLY

FIGURE 8

ITEM NO.	PART NO.	DESCRIPTION
1	13842*	Front Axle Support - RT52
2	13962*	Weldment - Right; RT52 Deck
3	13961*	Weldment - Left; RT52 Deck
4	NB170	Nut - Serr Flange 5/16-18 ZY Case Hrd
5	13844*	Rear Axle Support - RT52, Left
6	10548	Bolt - Serr Flange, 5/16-18 X 1
7	13843*	Rear Axle Support - RT52, Right
8	13836*	Deck - RT52; Center
9	13992*	Angle - Deck Support; RT52

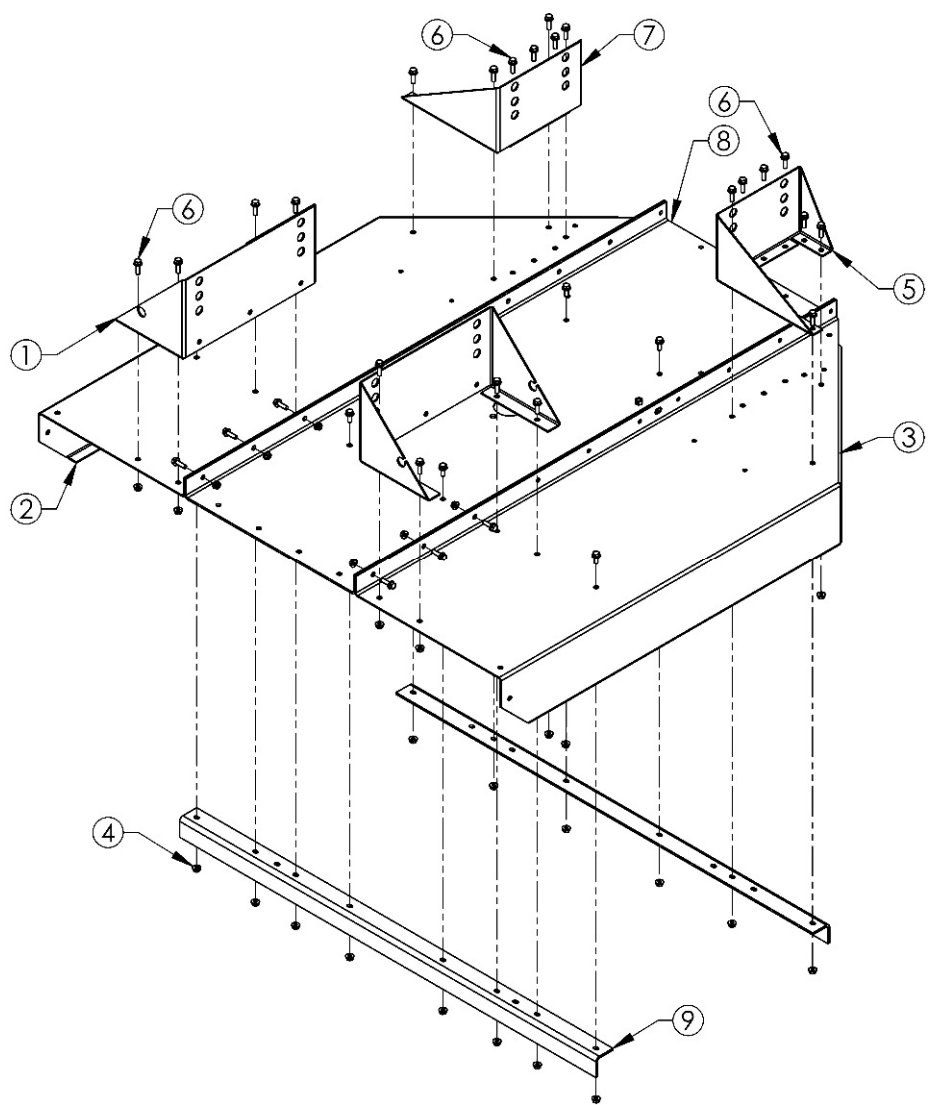

REAR DEBRIS GUARD

FIGURE 10

ITEM NO.	PART NO.	DESCRIPTION
1	13859	Rear Debris Flap
2	NB170	Nut - Serr Flange 5/16-18 ZY Case Hrd
3	13858*	Rear Flap Support
4	NB181	Nut - Nyloc 5/16-18 ZY
5	13962*	Weldment - Right; RT52 Deck
6	NB596	Bolt - Serr Flange, 5/16-18 X 3/4 Gr 5
7	13836*	Deck - RT52; Center
8	13860*	Clamping Plate - Rear Debris Guard; RT52
9	13961*	Weldment - Left; RT52 Deck
10	10548*	Bolt - Serr Flange, 5/16-18X1GR5 ZY

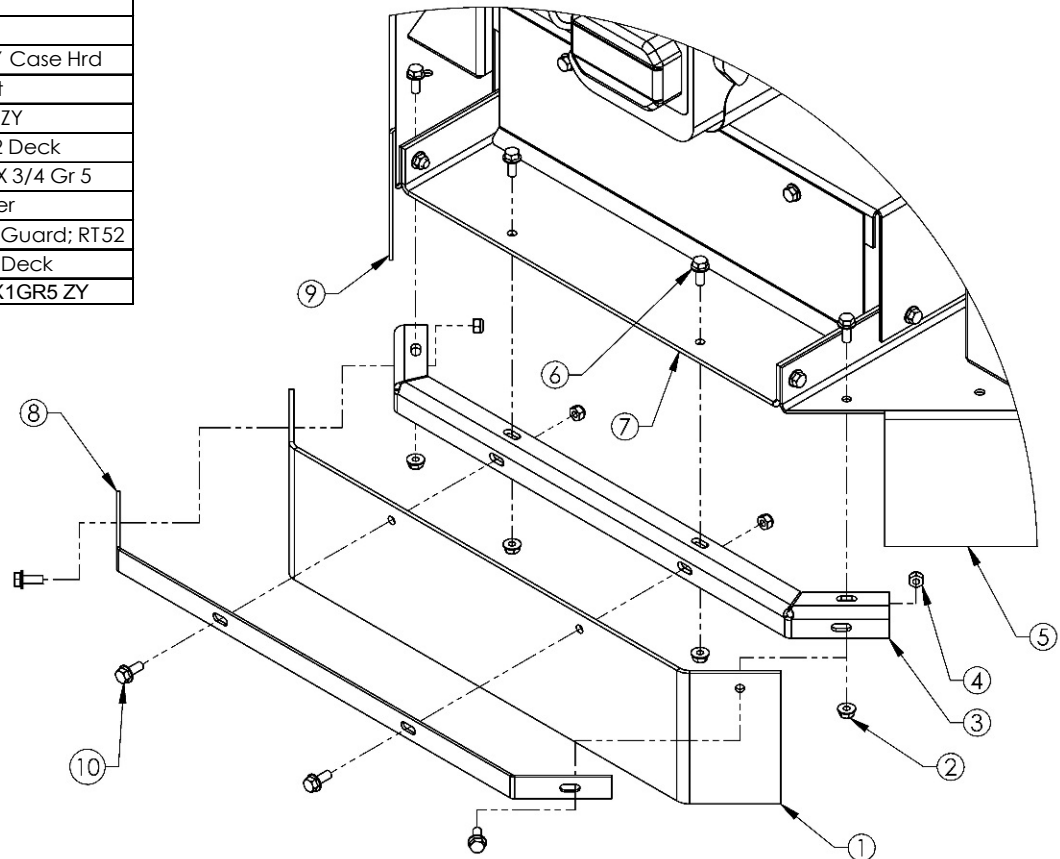

CONSOLE ASSEMBLY

FIGURE 8

Item No.	Description	Part #
1†	Keys - For Key Switch (Set of Two)	KSK
2†	Nut - Key Switch	9087
3†	Washer - Lock, Key Switch	9088
4	Switch - PTO	3605
5	Plate - Switch Backer	10810*
6	Console - Weldment	6108*
7†	Switch - Key	3623
8	Nut - Kep 8-32	NB201
9	Washer - SAE Flat 1/4	NB274
10	Screw - Phil Truss 8-32 X 1/2	NB197
11	Knob - T, Throttle Cable	4226K
12	Console - Engage; FM60	686C mod
13	Screw - #8 X 1/2, Serr Flange Self Tap	21298
1-13	Console Assembly	21327
14	Cable - Throttle, 169.5"	7510
15	Wiring Harness	20902
1-15	Console & Wiring Harness Assembly	20898

† Items 1, 2, 3 & 7 can be purchased as Key Switch Kit 21329.

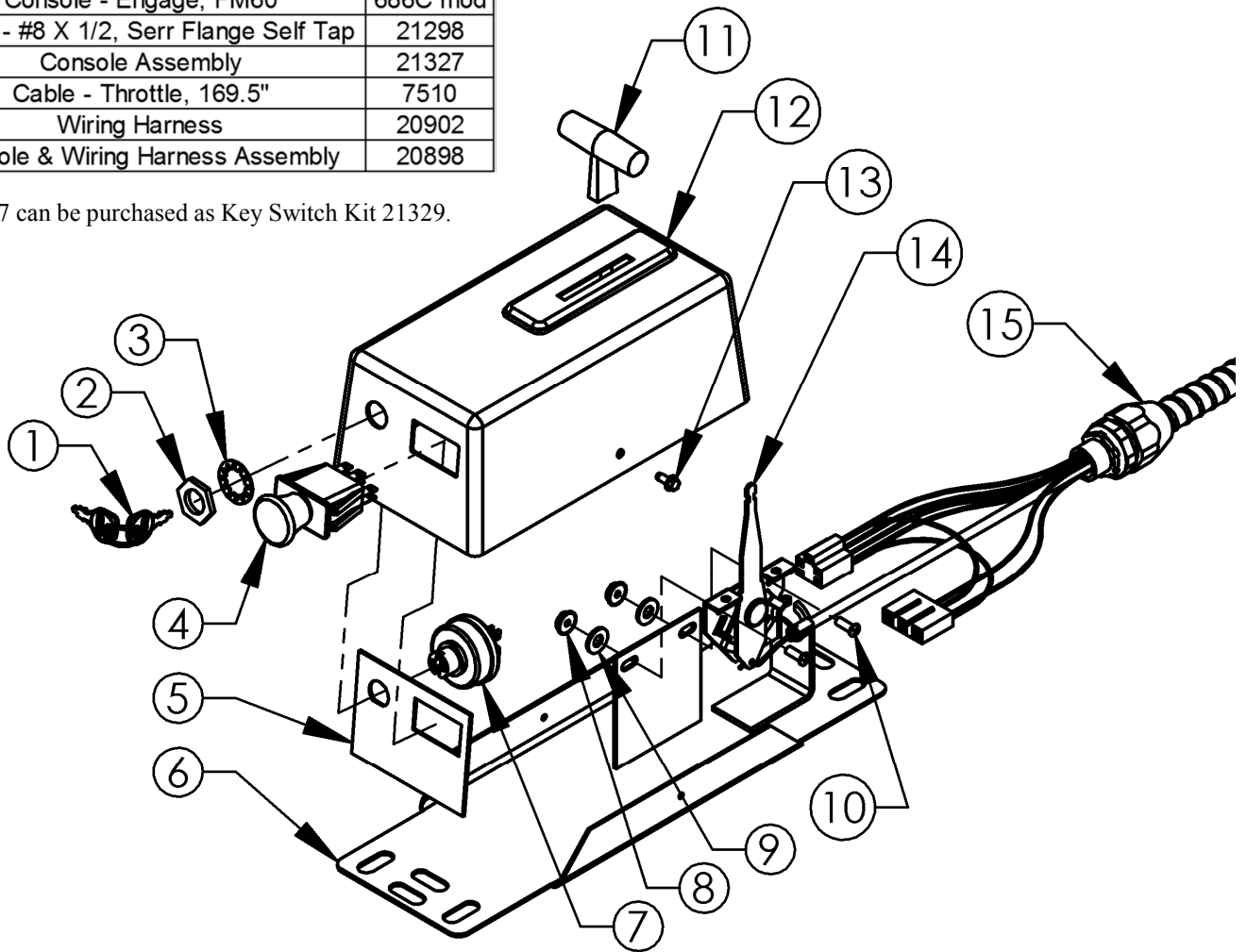

When mounting the console assembly it may be necessary to mount it directly to the hitch tube depending on the vehicle you are towing it with. Some vehicle configurations will allow the console to be mounted to the vehicle (i.e. ATV rack). Make sure the wiring harness is secure and will not drag the ground. Periodically check to make sure all hardware is tight and the wiring harness is secure. NEVER operate this machine without the wiring harness being secure.

ENGINE TO BLADE PULLEY
CONFIGURATION

FIGURE 9

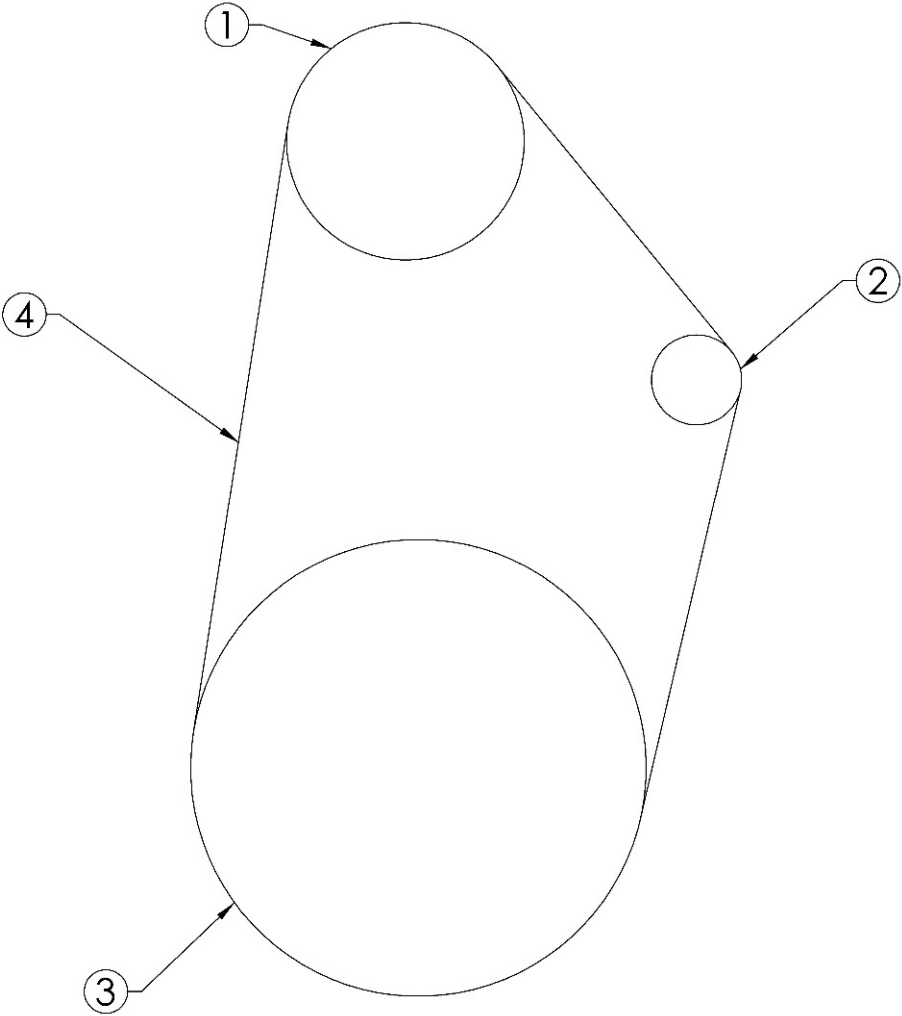

ITEM NO.	PART NO.	DESCRIPTION
1	3813	Clutch - Electric
2	B527	Pulley - Idler, OD-3.25", ID-3/8"
3	13863	Pulley - 14" X 1" ID
4	14276	Belt, 5/8" x 64"

CARBON CANISTER ASSEMBLY - Only included on "CA" models.

ITEM NO.	PART NO.	DESCRIPTION
1	18224	Carbon Canister - 2.50 Gallon, 3/16 Line
2	18219	Cable Tie - Carbon Canister
3	024900	Nut - 10-24 Nylon Lock
4	17127	Bracket - Carbon Canister, ZT
5	024203	Screw - 10-24 X 3/4 Phil Truss Head ZP

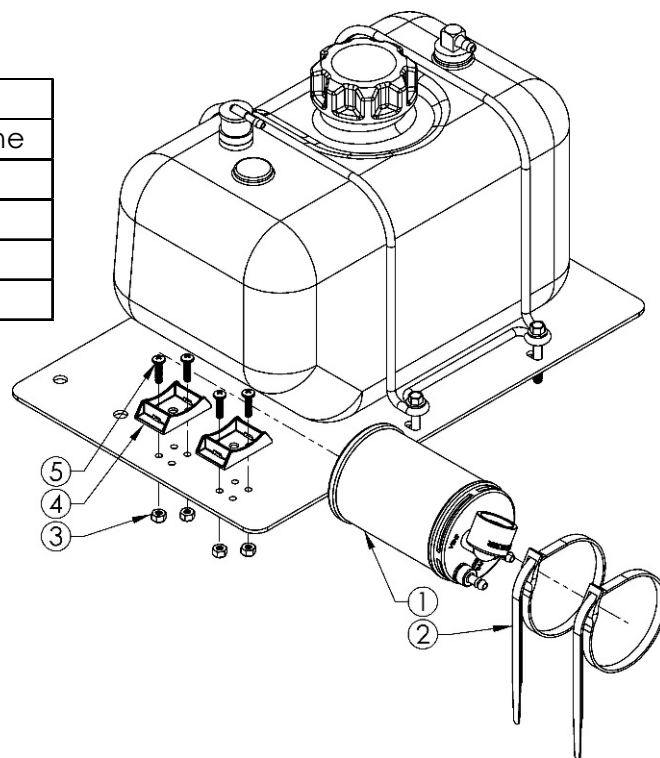

COMMON REPAIR PARTS

Your 52" Trail Cutter has been produced with components designed specific to this machine. Although standard V-belts, springs, bearings, blades, pulleys, hardware, etc. look similar to parts used on other machinery, they may in some cases be made of a different construction and/or materials.

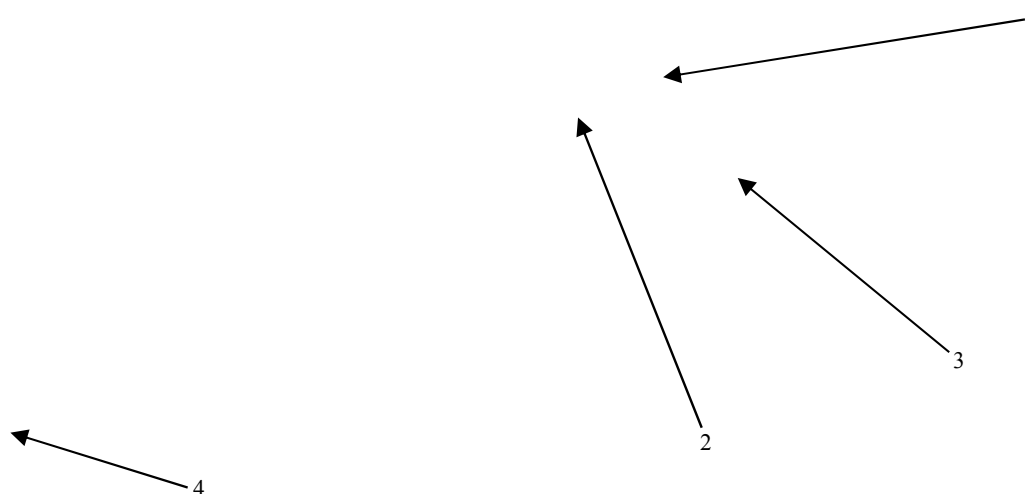

ITEM NO.	PART NO.	DESCRIPTION
1	1002004	Solenoid - 3 Pole
2	18214	Fuel Tank - 2.5 Gallon, Carb
3	N/A	U1 Battery (Not Included)
4	7365	Coupler - 2" Ball
NOT SHOWN	BCSR	Cable - Battery (10' Red)
NOT SHOWN	BCS	Cable - Battery (Black 10')
NOT SHOWN	BCBT	Boot - Rubber, Small, Battery Cable
NOT SHOWN	14276	Belt, 5/8" x 64" (RT52)
NOT SHOWN	AS069	Electrical - 10 Amp Fuse
NOT SHOWN	NB600	Nut - M6-1.0 Yellow Zinc Class 8

When ordering replacement parts

* = USE PAINT CODE: TK=BLACK

Maintenance Log

Date Oil Changed	Date Changed Belts	Date Blades Sharpen or Changed	Notes

swisherinc.com

OWNER'S MANUAL

MODEL NO.

RC14552CPKA

RC14552CPKA-CA



IMPORTANT

**Read and follow all
Safety Precautions
and Instructions
before operating this
equipment.**

52" COUNTRY CUT TRAIL CUTTER COMMERCIAL PRO

Each mower has its own model number. Each engine has its own model number. The model number for the mower will be found on the right hand side of the motor mount. The model number for the engine will be found on the top of the valve cover.

All mower parts listed herein may be ordered directly from Swisher or your nearest Swisher dealer.

All engine parts may be ordered from the nearest dealer of the engine supplied with your mower.

WHEN ORDERING PARTS, PLEASE HAVE THE FOLLOWING INFORMATION AVAILABLE:

- * PRODUCT - RC52" COUNTRY CUT TRAIL CUTTER
- * SERIAL NUMBER - _____
- * MODEL NUMBER - _____
- * ENGINE MODEL NUMBER - _____
- TYPE - _____
- * PART NUMBER
- * PART DESCRIPTION

TELEPHONE - 1-800-222-8183

FAX - 1-660-747-8650

SWISHER ACQUISITION INC.

1602 CORPORATE DRIVE

WARRENSBURG, MO 64093

www.swisherinc.com

SWISHER®

CHANGING YOUR LANDSCAPE SINCE 1945