



TIMBER BEAM CUTTER

OWNER'S MANUAL



WARNING:

Carefully read and understand all **ASSEMBLY AND OPERATION INSTRUCTIONS** before operating. Failure to follow the safety rules and other basic safety precautions may result in serious personal injury.

MODEL# TMW-57

08252016

TIMBER BEAM CUTTER OWNER'S MANUAL

Thank you very much for choosing a Timber Tuff product. For future reference, please complete the owner's record below:

Model: _____ Purchase Date: _____

Save the receipt, the warranty and these instructions. It is important that you read the entire manual to become familiar with this product before you begin using it.

This product is designed for certain applications only. The manufacturer and/or distributor cannot be responsible for issues arising from modification. We strongly recommend that this product not be modified and/or used for any application other than that for which it was designed. If you have any questions relative to a particular application, DO NOT use the product until you have first contacted the distributor to determine if it can, or should, be performed on the product.

For technical questions, please call **1-218-943-6290**.

TECHNICAL SPECIFICATIONS

For Use With	Any size chainsaw
Construction	Solid steel construction with a durable powder-coat finish to resist corrosion
Product Dimensions L x W x H	12" x 7 1/2" x 2 1/4"

GENERAL SAFETY RULES

 **WARNING:** Read and understand all instructions. Failure to follow all instructions listed below may result in serious injury.

 **CAUTION:** Do not allow persons to operate or assemble this beam cutter until they have read this manual and have developed a thorough understanding of how the beam cutter works.

 **WARNING:** The warnings, cautions, and instructions discussed in this instruction manual cannot cover all possible conditions or situations that could occur. It must be understood by the operator that common sense and caution are factors that cannot be built into this product, but must be supplied by the operator.

SAVE THESE INSTRUCTIONS

WORK AREA

- **Keep work area clean**, free of clutter, and well-lit. Cluttered and dark work areas can cause accidents.
- **Keep children and bystanders** away while using the beam cutter. Distractions can cause you to lose control, so visitors should remain at a safe distance from the work area.
- **Be alert of your surroundings.** Using the beam cutter in confined work areas may put you in a dangerous situation.

PERSONAL SAFETY

- **Stay alert**, watch what you are doing, and use common sense when using the beam cutter. Do not use the beam cutter while you are tired or under the influence of drugs, alcohol, or medication. A moment of inattention while operating the beam cutter may result in serious personal injury.
- **Dress properly.** Do not wear loose clothing, dangling objects, or jewelry. Keep your hair, clothing, and gloves away from moving parts.
- Logging chaps should be used at all times while operating a chainsaw.

TIMBER BEAM CUTTER OWNER'S MANUAL

BEAM CUTTER USE AND CARE

- **Do not modify the beam cutter in any way.** Unauthorized modification may impair the function and/or safety and could affect the life of the equipment.
- **Always check for damaged or worn out parts before using the beam cutter.** Broken parts will affect the beam cutter operation. Replace or repair damaged or worn parts immediately.
- **The beam cutter is for OUTDOOR use ONLY.**

CAUTION:

- **When lifting logs, ALWAYS use CAUTION as logs can fall or drop.** Heavy logs can cause injury to feet, legs, and hands. **ALWAYS wear protective clothing including steel toe boots, leather gloves, and leg and arm protection.** Logging chaps should be used at all times while operating a chainsaw.

PARTS DIAGRAM:

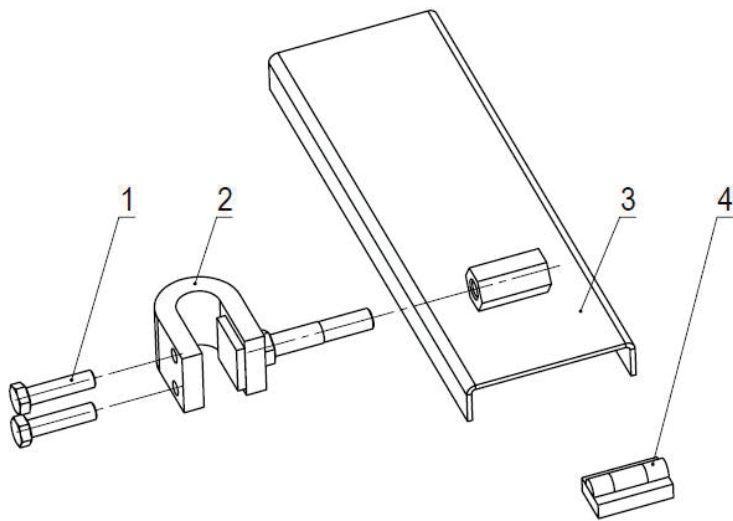

PARTS LIST:

Part#	Description	Qty.	Part#	Description	Qty.
1	Bolt M10×40	2	3	Frame	1
2	U clamp	1	4	Leveling Bubble	1

For replacement parts and technical questions, please call **1-218-943-6290**.

TIMBER BEAM CUTTER OWNER'S MANUAL

MAINTENANCE

- **Maintain your beam cutter.** It is recommended that the general condition of the beam cutter be examined before it is used. Keep the beam cutter in good repair by adopting a program of conscientious repair and maintenance in accordance with the recommended procedures found in this manual.
- **Be sure to tighten all nuts and bolts before use.**
- **Keep the beam cutter clean.** A properly maintained beam cutter will work more effectively. Keep all parts dry, clean, and free from oil and grease.
- **Cleaning.** Use only soap and a damp cloth to clean your beam cutter.

WARRANTY

One-year limited parts warranty



BAC Industries
PO BOX 155
Miltona, MN 56354

Made in CHINA