

Leigh Country

Authentic Country Living

IMPORTANT: READ CAREFULLY BEFORE BEGINNING

Do not tighten bolts until fully assembled.









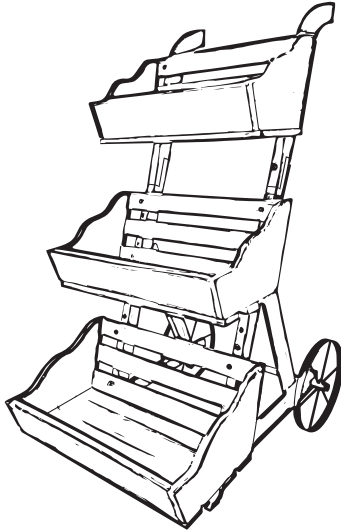

Warning
 * Do not climb.
 * For decor only; not intended for cart usage.

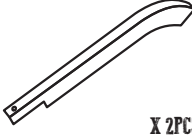
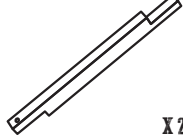
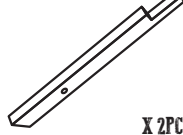
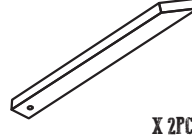
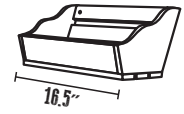
GARDEN CART PLANTER

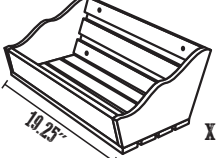
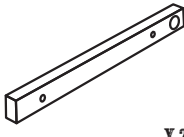
ITEM # TX 93966

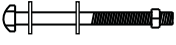

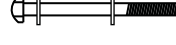
PARTS AND HARDWARE LIST

①	②	③	④	
 X 2PCS	 X 2PCS	 X 2PCS	 X 2PCS	
⑤	⑥	⑦	 X 1PC 16.5"  X 1PC 18"  X 1PC 19.25"	
 X 2PCS	 X 2PCS	 X 1PC		
A	B	C	D	E
L: 2"  X 12PCS	L: 2.55"  X 6PCS	L: 3"  X 2PCS	L: 1.2"  X 6PCS	 X 6PCS

STEP 1:

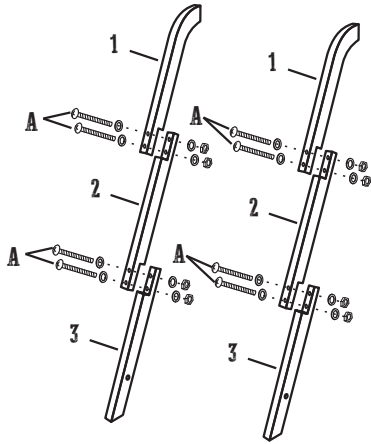

STEP 2:

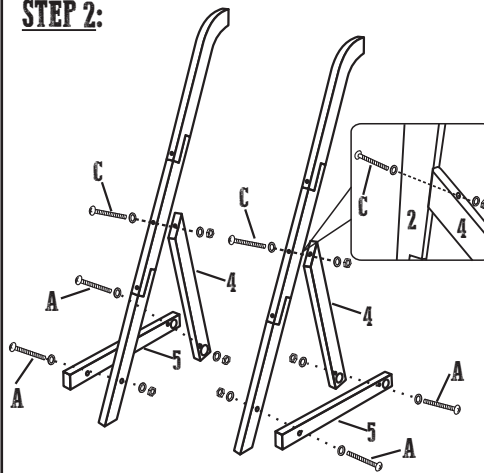

STEP 3:

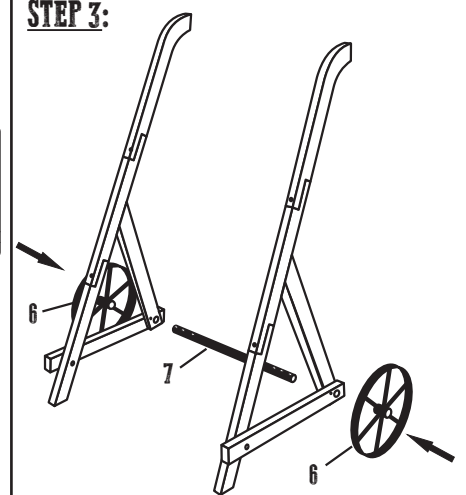

STEP 4:

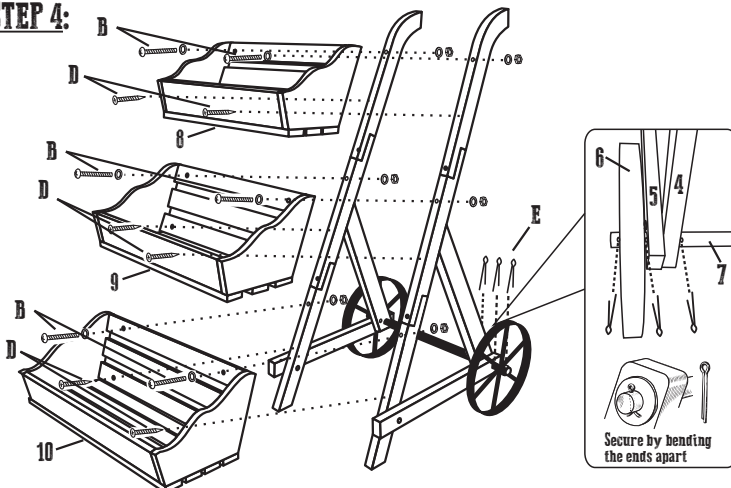

STEP 5:

Tighten all nuts, bolts, once every part and assembled pieces are in place.

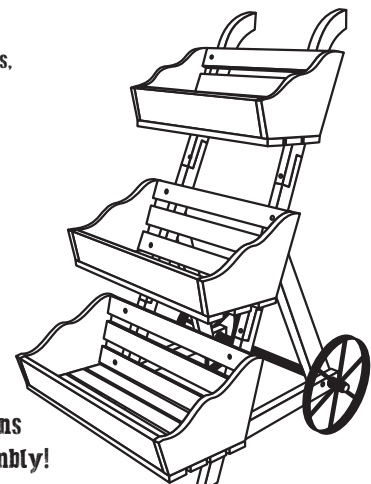

Congratulations on your assembly!

Secure by bending the ends apart

Limited Warranty and Care Instructions

LIMITED ONE YEAR WARRANTY (NON-TRANSFERABLE)

This product is covered under United General Supply's (UGS) one (1) year limited warranty. To the original purchaser of this piece of furniture, cooler or accessory; UGS warrants that it will be free from defects in material and workmanship for up to one year from the date of purchase under normal use and proper care.

Replacement of defective or missing parts will be sent at no charge to the customer for a period of 30 days from the date of purchase. UGS will no longer be responsible for missing parts or hardware 30 days after date of purchase. Freight, packaging, labor or material charges to and from our customer service center is not covered under the warranty and is therefore the customer's responsibility.

The limited warranty does not cover this piece of furniture, cooler or accessory for commercial purposes, abusive use, damage by modification, freeze damage, rust, fading and issues caused by improper care.

For minor defects or missing parts/hardware, please contact customer service immediately upon purchase. Please do not return product to the store unless the product is irreparable. A customer service agent may help determine whether the damage is repairable and will provide further instructions.

For returns and refunds, please refer to your local store return policy with proof of purchase.

Proof of purchase (dated register receipt) will be required for warranty claims.

PROPER CARE INSTRUCTIONS

If left untreated, wood will naturally weather. During long periods of non-use, store furniture or cooler in covered and dry place. For the least maintenance, place your furniture, cooler, or accessory under a covered area.

Customer Service may be reached Monday through Friday from 9:00a.m. to 5:00p.m. CST.

HELP@UGSCO.COM OR 1-877-87LEIGH (53444)

Leigh 
Country

Authentic Country Living

DISTRIBUTED BY:
UNITED GENERAL SUPPLY CO., INC.
HOUSTON, TX 77036

www.LeighCountry.com

© 2016 UGS Co., Inc. All Rights Reserved