



FRESHEN AIRE SCENTED AIR MOVER

OWNER'S MANUAL

P-250AT/P-450AT
(115V/60Hz)



XPOWER MANUFACTURE, INC.
220 Clary Avenue
San Gabriel, CA 91776, USA
Tel: 626-285-3301 Fax: 626-285-3302
www.xpower.ws



PLEASE READ AND SAVE THESE INSTRUCTIONS

INDEX

Introduction	2
Operation	3
Safety Instructions	4
Specifications	5
Parts List	6
Maintenance/Troubleshooting	7
Products & Accessories	8
Warranty/Service	9
Warranty Registration Form	10

INTRODUCTION

Create an inviting atmosphere for your home or business with XPOWER Scented Air Movers. By combining powerful air flow with a patented fragranced bead cartridge this unit quickly scents rooms while efficiently ventilating or drying. Enhance the ambiance of a variety of spaces using a scented bead cartridge that is easily refilled with a fragrance of your choice. Available in models from 1/5 HP to 1HP, this professional equipment features a fully integrated motor and housing design to ensure optimum performance and years of service.

Industry Leading Design

- Super Quiet Motor
- Lightweight
- Easy Carrying Handle
- Rugged Housing
- 3-Hour Timer
- 3-Speed Switch

Multiple Applications /Uses

- Jan/San
- Hotels/Hospitality
- Spas & Salons
- Retail
- Gyms & Fitness Centers
- Home

What's inside: Air Mover, Refillable Scented Bead Cartridge, Lime Scented Bead Sample

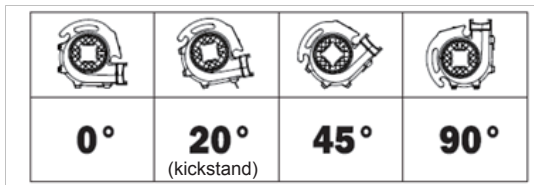

AIR MOVER STORAGE:

Air Movers can be stacked (up to 4) on their sides for storage.

NOTICE:

Stacking feature is not secure for transportation.



OPERATION

READ ALL INSTRUCTIONS BEFORE OPERATING

1. Prior to plugging the unit into the power source, inspect completely for any shipping damage.
2. Plug the electrical cord into the power outlet.
3. Carefully place the unit on a stable, flat, dry surface.
4. Position unit to desired angle to direct air flow.
5. Turn switch to desired speed and make sure unit operates normally
6. Unit's on board power outlet can be daisy chained to additional units.
7. To reduce the risk of injury, close supervision is necessary when an appliance is used near children. Do not allow children to play with or around an Air Mover at any time.

SETTING OPTIONAL TIMER

Turn dial to select desired time

(1-180 minutes)

"ON" position sets unit for continuous use

SPEEDS



FILLING SCENTED CARTRIDGE

1. Remove scent cartridge from the air mover by turning counter-clockwise while unit is positioned facing you
2. Flip hinged top open
3. Open scented bead packet sample that is included with your purchase
4. Fill cartridge according to the scent intensity desired
5. Reassemble by screwing cartridge back into the unit clock-wise



WARNING: KEEP OUT OF REACH OF CHILDREN

SAFETY INSTRUCTIONS



WARNING - TO REDUCE RISK OF FIRE, ELECTRIC SHOCK OR INJURY:

1. To prevent electric shock, do not operate the unit in standing water. Never plug in or unplug the unit with wet hands or while standing in water.
2. To avoid risk of injury, do not direct air flow at face or body.
3. To reduce the risk of fire or electric shock, do not use the Air Mover with any solid-state speed control device.
4. Use only with GFCI protected receptacles. Please contact a qualified electrician for verification and / or installation of a GFCI receptacle if necessary.
5. Do not operate the Air Mover with a damaged cord or plug. Discard the unit or return it to an authorized service facility for examination and/or repair.
6. Unplug the Air Mover from the power supply before servicing or cleaning.
7. Do not run the power cord under carpeting. Do not cover the power cord with throw rugs, runners, or similar coverings. Place the power cord away from traffic area to prevent tripping.
8. Do not allow children to play with or around the Air Mover at any time.
9. Do not move or carry the Air Mover while unit is operating.
10. It's Automatically Operated Device, To Reduce The Risk Of Injury Disconnect From Power Supply Before Servicing.

PART LIST

Item No.	Parts Name	Item No.	Parts Name
1	Circuit Breaker	2	Capacitor
3	AC Receptacles	4	Grid Cover (Motor Side)
5	Left Housing	6	Switch & Timer plate
7-1&7-2	Switch & Timer	8-1&8-2	Switch knob & Timer Knob
9	Motor	10	Power Cord
11	Fan	12	Right Housing
13	Grid Cover(Fan Side)	14	Frangance Cartridge
15	Air Outlet Grid Cover	16	Kick Stand
17	Rubber Feet (Not Shown)	18	Screws and Nuts (Not Shown)

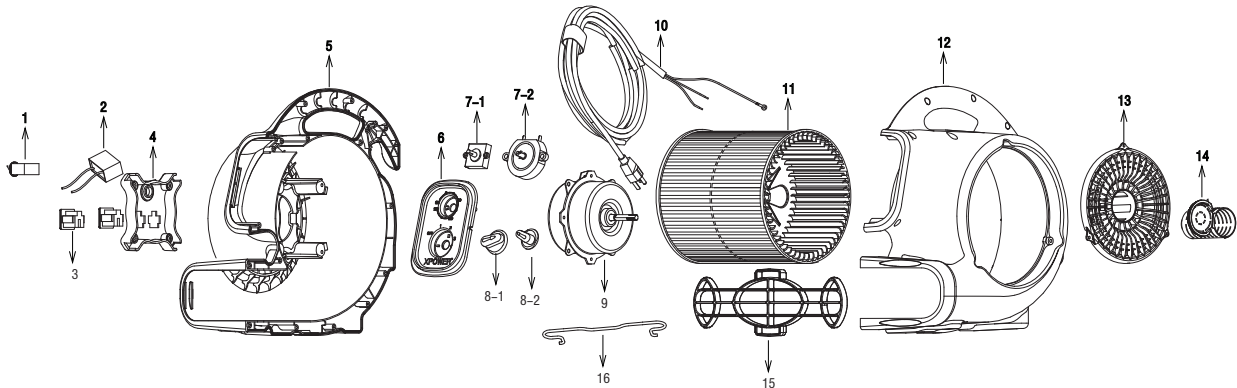

SPECIFICATIONS

Model	P-250AT	P-450AT
Volt/Frequency	115V/60Hz	115V/60Hz
Power	1/5HP	1/3HP
Amp	2.3 Amps	3.8Amps
Rated Airflow (On High)	800CFM	2000CFM
RPM (Low/Medium/High)	1000/1250/1500	1000/1350/1600
Speeds	Three	Three
Built-In Power Outlet / Daisy Chain	Yes	Yes
3-Hour Timer	Yes	Yes
Positions	4(0°,20°Kickstand,45°,90°)	4(0°,20°Kickstand,45°,90°)
Unit / Box Weight	9.9 lbs./11.1 lbs.	16.4lbs./20.4lbs.
Unit / Box Size (LxWxH)	10.7"x12.4"x13.3"/13.6"x12.8"x11"	13.9"x14.8"x14.6"/15.5"x15"x15.2"
Power Cord (Length/Size)	10'/14AWG	20'/14AWG
Overheating Protection	Thermally Protected	Thermally Protected
Housing	Injection Mold / Polypropylene(PP)	Injection Mold / Polypropylene(PP)
Safety Certification	ETL / C-ETL	ETL / C-ETL

MAINTENANCE/TROUBLESHOOTING

1. To keep unit clean, use a damp cloth to wipe the surface of the housing.
2. Never clean Air Mover by rinsing or spraying directly with water.
3. When not in use, unplug and store unit in a dry indoor place out of reach of children.
4. Always disconnect Air Mover from its power source before performing any maintenance or cleaning.

For any problems not listed below, call your local distributor or contact the XPOWER Service Department .

PROBLEM	POSSIBLE CAUSE	SOLUTION
Air Mover not running	No power input	Plug in the Air Mover, check circuit breaker
	Switch not turned on	Turn on switch
	Air Mover fan wheel jammed	Remove material jamming fan wheel
	Intake or exhaust blocked	Turn unit off and allow to cool, then remove blockage
Air Mover vibrates	Accumulation of dirt on fan blades	Clean Air Mover fan Blades

XPOWER LIMITED WARRANTY (USA)

XPOWER's Limited Warranty covers the unit (excludes POWER CORD) from defects in material and craftsmanship. The Warranty covers normal use for a term of one year from the original date of purchase including parts, labor and one way shipping. Non-contiguous states must pay for roundtrip freight. A purchase receipt must be provided.

Important!

This warranty does not cover or apply to defects due directly or indirectly to misuse, abuse, disassembly, alteration, corrosive chemicals, improper voltage, fire, flood, negligence, accident, improperly or incorrectly performed maintenance or repair, or failure to perform necessary maintenance or repair, or if the use of this product is not in compliance with the instructions and specifications for its use.

Service

For Warranty service and parts replacement (US users only), you must:

- A. Call 1-855-855-8868 for a RMA (Return-Merchandise-Authorization) number.
- B. Have original proof of purchase.
- C. Use the original undamaged packaging or an industrial certified packaging method.

End user will be responsible to ship the unit (with RMA Number showing on the shipping label) to the XPOWER Service Department. XPOWER to inspect, assess and advise the repairs needed and the applicable cost, if any. For users outside the US, please contact XPOWER Distributor in your country or region for Warranty service and parts replacement.

PRODUCTS & ACCESSORIES

Visit www.xpower.ws for Complete Product Selection

- Air Movers
- Axial Fans
- Air Scrubbers
- Dehumidifiers
- Pet Force Dryers
- Pet Stand Dryers
- Cage Dryers
- Inflatable Blowers

Additional Scented Bead Fragrances Available at www.airchaser.com

XPOWER MANUFACTURER, INC. 220 Clary Avenue San Gabriel, CA, USA

Tel: 626-285-3301 Fax: 626-285-3302

Warranty Registration (for US user only)

For your product warranty, please complete and mail / fax this form to XPOWER MANUFACTURE, INC.

Address: 220 Clary Ave., San Gabriel, CA 91776. Tel: 626-285-3301 Fax: 626-285-3302

(For your convenience, register your product online at xpower.ws)

Company Name / Contact Person / Title _____

Address _____ City _____

State / Province _____ Zip _____ Country _____

Phone _____ Fax _____ E-mail _____

Model # _____ Serial #: _____

Date of Purchase ____/____/____ Purchased From _____

Additional Comments / Suggestions _____



From: _____

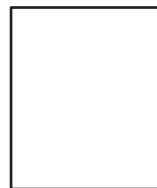

TO:

XPOWER MANUFACTURE, INC.
220 Clary Avenue
San Gabriel, CA, USA

