



PLEASE READ AND SAVE THESE INSTRUCTIONS

Cage Dryer (Air Mover + Multi Drying Kit)

OWNER'S MANUAL

XPOWER Manufacture, Inc.
240 Clary Ave.
San Gabriel, CA 91776, USA
Tel: 626-285-3301, Fax 626-285-3302
www.xpower.com

Air Mover



MDK

Models: X-430TF + 430MDK
X-800TF + 800MDK

Index

Introduction	2
Operations	3
Multiple Drying Kit	4~5
Safety Instructions	6
Maintenance / Troubleshooting	7
Specifications	8
Parts List	9
Limited Warranty	10

Introduction

XPOWER Cage Dryers, Air Movers with Multi Drying Kits (MDKs), are specially designed for the professional pet grooming industry. Cage Dryers are offered in two models: **X-430TF w/ 430MDK** and **X-800TF w/ 800MDK**.



With the most efficient engineering design, professional Level Multifunctional Air Movers X-430TF and X-800TF are ETL/CETL Certified, and also used in many other industries.

Features:

- Low power draw with an high velocity air flow from 3,200 to 3,600 CFM
- Super quiet motor and super lightweight.
- Easy carrying handle and stackable up to 3-4 units high.
- Easy and quick to disassemble for thorough cleaning and service.
- Power cord lengths are 20' for P models and 25' for X models.
- Easy cord wrap on handle.
- 3-hour Timer and two Filters included
- 3-speed switch.
- Durable and rugged housing with 1 years warranty.
- 4 air-flow positions for other models (0°, 20°, 45°, 90°).



AIR MOVER STORAGE:

Air Movers can be stacked (up to 3) on their sides for storage.

NOTICE:

Stacking feature is not secure for transportation. Must remove the filters before stacking.
(For unit with filters)

Operations

Carefully read Safety Instructions (page 6) before starting operations

1. Prior to plugging the unit into the power source, inspect completely for any shipping damage.
2. Carefully place the Air Mover unit on a stable, flat dry surface.
3. Plug the electrical cord into the power outlet.
4. The unit is capable to be used at 4 different angles to direct air flow, except that the unit with handle is at 3 different angles.
5. Turn the switch to select desired speed, while making sure unit operates normally.
6. All Air Movers in operation must be supervised at all times.



Timer Instruction

Use the Timer to set the preferred time from 1 min to 180 min

Filters: a set of Filters is included with air mover, which will help prevent small debris and dust from entering the unit. To clean the filters, simply remove the filters from the unit and wash with warm soapy water, rinse with clean water and let dry thoroughly before reinstalling.

Installation:

Filters snaps into the air inlets.

Note:

The filter I is for Motor Side,
The filter II is for Fan Side

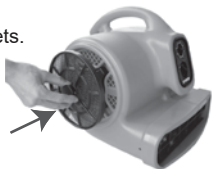

Filter Removal:

Pull the filters off the unit.

Note:

After cleaning make sure the
filters are dry before
reinstalling.



Multiple Drying Kit - 430/800 MDK

As a Cage Dryer, the Multiple Drying Kit, 430MDK / 800MDK combined with X-430TF / X-800TF is specially designed for professional pet grooming industry.



Attach to Air Mover



Use for Cage Dryer



MDK



The MDK includes:

- (A) Air Mover Adapter (1)
- (B) 8 ft Flex Hoses (3)
- (C) Airflow Adjustment Doors (3)
- (D) Hose Clamps (6)

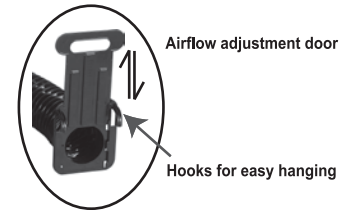

Airflow adjustment door

Hooks for easy hanging

See next page for MDK installation



1) Clamp Air Mover Adapter (A) to air-outlet of the air mover. Make sure the Snap Lock Buckles on both sides of the Adapter are securely locked.



2) Attach each Flex Hose (B) to Adapter (A) by using the Hose Clamp (D). Tighten Hose Clamp (D) with a flat head screwdriver (not included).



3) At the other end of each Hose (B), attach the Airflow Adjustment Door by using the remaining Hose Clamps (D).

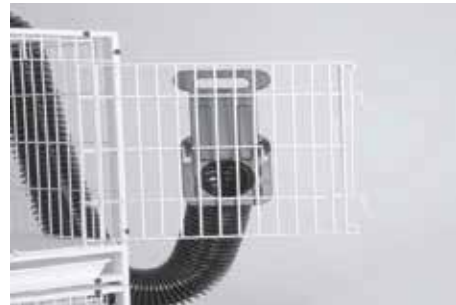

4) Use the cage hanger on the Airflow Adjustment Door (C) to place the Flex Hose (B) on a desired cage.

Safety Instructions

1. To prevent electric shock, do not operate the unit in standing water. Never plug in or unplug the unit with wet hands or while standing in water.
2. To avoid risk of injury, do not direct air flow at face or any part of body.
3. To reduce the risk of fire or electric shock, do not use the Air Mover with any solid-state speed control device.
4. Use only with GFCI protected receptacles. Please contact a qualified electrician for verification and / or install GFCI receptacle if necessary.
5. Do not operate any Air Mover with a damaged cord or plug. Discard the unit or return it to an authorized service facility for examination and/or repair.
6. Unplug the Air Mover from the power supply before moving, servicing or cleaning.
7. Do not run the power cord under carpeting. Do not cover the power cord with throw rugs, runners, or similar coverings. Place the power cord away from traffic area to prevent tripping.
8. Do not allow children to play with or around an Air Mover at any time.
9. Do not move or carry an Air Mover while unit is operating.
10. All Air Movers in operation must be supervised at all times.

Maintenance Instructions

1. To keep the Air Mover clean, use a damp cloth to wipe the surface of the housing.
2. Never clean the Air Mover with water directly.
3. When not in use, unplug and store the Air Mover in a dry indoor place out of reach of children.
4. Always disconnect the Air Mover from its power source before performing any maintenance or cleaning.
5. Clean the filters (for unit with filters) often as necessary to avoid loss of airflow when available.

Troubleshooting

For any problems not listed below, call your local distributor or contact our Service Department

PROBLEM	POSSIBLE CAUSE	SOLUTION
Air Mover not running	No power input	Plug in the Air Mover; check circuit breaker
	Switch not turned on	Turn on switch
	Air Mover fan wheel jammed	Remove material jamming fan wheel
	Intake or exhaust blocked	Turn unit off and allow to cool, then remove blockage
Air Mover vibrates	Accumulation of dirt on fan blades	Clean Air Mover fan blades

Specifications

Model (Air Mover)	X-430TF	X-800TF
Volts	115 V / 60 Hz	115 V / 60 Hz
Motor	1/3 HP	3/4 HP
Airflow	2,000 CFM	3,200 CFM
Maximum AMP	3.8 AMPS	7.5 AMPS
RPM (L / M / H)	1,000 / 1,350 / 1,600	1,100 / 1,250 / 1,350
Net / Gross Weight	17 lbs. / 21 lbs.	24.8 lbs. / 29.3 lbs.
Unit / Box Dimensions	13.9 x 14.8 x 14.6 / 15.5 x 15 x 15.2 inch	15.9 x 17.5 x 18.5 / 19.3 x 18.7 x 17.3 inch
Positions	4 (0°, 20° Kickstand, 45° & 90°)	4 (0°, 20° Kickstand, 45° & 90°)
Timer	Included (0 - 180 min)	Included (0-180 min)
Filter	Included (one set)	Included (one set)
Speeds	3	3
Overheating Protecting	Dual Thermally Protected	Dual Thermally Protected
Cord Length	20 ft	25 ft
Housing / Material / Color	Injection Mold / ABS / Blue	Injection Mold / ABS / Blue

* All Air Movers are ETL/CETL certified

Air Mover Parts List

Item No.	Parts Name	Item No.	Parts Name
1	Left Housing	2	Grid Cover (Motor Side)
3	Timer & Switch Plate	4-1 & 4-2	Switch Knob & Timer Knob
5	Switch	6	Motor
7	Right Housing	8	Power Cord
9	Fan	10	Grid Cover (Fan Side)
11	Air Outlet Grid Cover	12	Kick Stand
13	Rubber Feet (Not Shown)	14	Screws and Nuts (Not Shown)
15	Capacitor	16	Filters

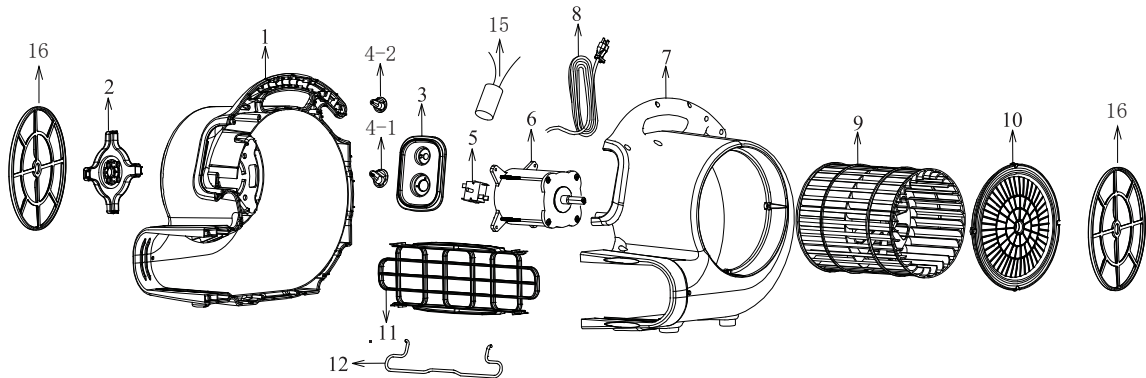

XPOWER Limited Warranty (USA)

XPOWER's Limited Warranty covers the unit (excludes POWER CORD) from defects in material and craftsmanship. The Warranty covers normal use for a term of one year from the original date of purchase including parts, labor and one way shipping. Non-contiguous states must pay for roundtrip freight. A purchase receipt must be provided.

Important!

This warranty does not cover or apply to defects due directly or indirectly to misuse, abuse, disassembly, alteration, corrosive chemicals, improper voltage, fire, flood, negligence, accident, improperly or incorrectly performed maintenance or repair, or failure to perform necessary maintenance or repair, or if the use of this product is not in compliance with the instructions and specifications for its use.

Service

For Warranty service and parts replacement (US users only), you must:

- A. Call 1-855-855-8868 for a RMA (Return-Merchandise-Authorization) number.
- B. Have original proof of purchase.
- C. Use the original undamaged packaging or an industrial certified packaging method.

End user will be responsible to ship the unit (with RMA Number showing on the shipping label) to the XPOWER Service Department. XPOWER to inspect, assess and advise the repairs needed and the applicable cost, if any.

For users outside the US, please contact XPOWER Distributor in your country or region for Warranty service and parts replacement.

WARRANTY REGISTRATION (for US user only)

For your product warranty, please complete and mail / fax this form to XPOWER MANUFACTURE, INC.

Address: 240 Clary Ave., San Gabriel, CA 91776. Tel: 626-285-3301 Fax: 626-285-3302

(For your convenience, register your product online at xpower.com)

Company Name / Contact Person / Title _____

Address _____ City _____

State / Province _____ Zip _____ Country _____

Phone _____ Fax _____ E-mail _____

Model # _____ **Serial #:** _____

Date of Purchase ____ / ____ / ____ **Purchased From** _____

Additional Comments / Suggestions _____