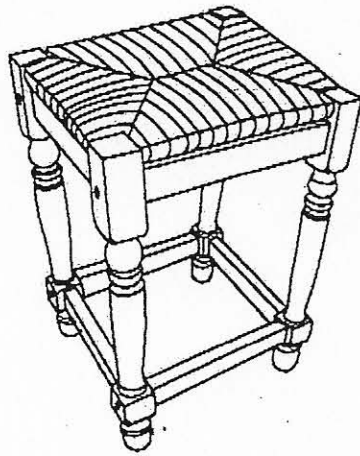

Assembly Instructions

**MODEL NO. : 2662-RTA-AB/MW/WAL
24" RUSH SEAT STOOL**

- Thank you for purchasing a Carolina Chair & Table Company product. This product has been designed for easy assembly and is constructed for durability. Please take the time to read and follow the assembly instructions carefully. If a part or hardware is missing or you have any difficulties in assembling this product, Please contact us Toll Free at 1-800-228-3876.

PARTS LIST :

1 RUSH SEAT	1 PC.
2 SIDE FRAME	2 PCS.
3 TOP RAIL	2 PCS.
4 BOTTOM RAIL	2 PCS.

HARDWARE LIST :

A JCBC SCREW-M6x70mm	8 PCS.
B BARREL NUT	8 PCS.
C WOOD BUTTON	8 PCS.
D PAN HEAD WOOD SCREW - 38mm	8 PCS.
E ALLEN KEY-M4	1 PC.
F SPRING WASHER-M6	8 PCS.

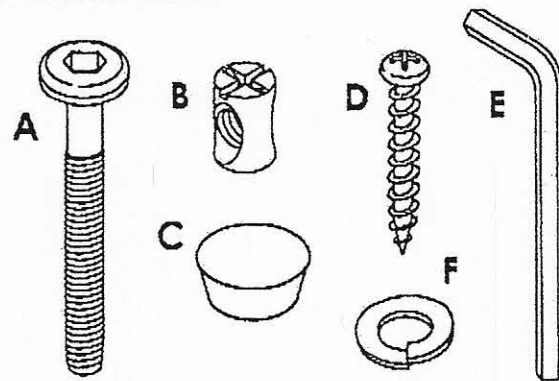
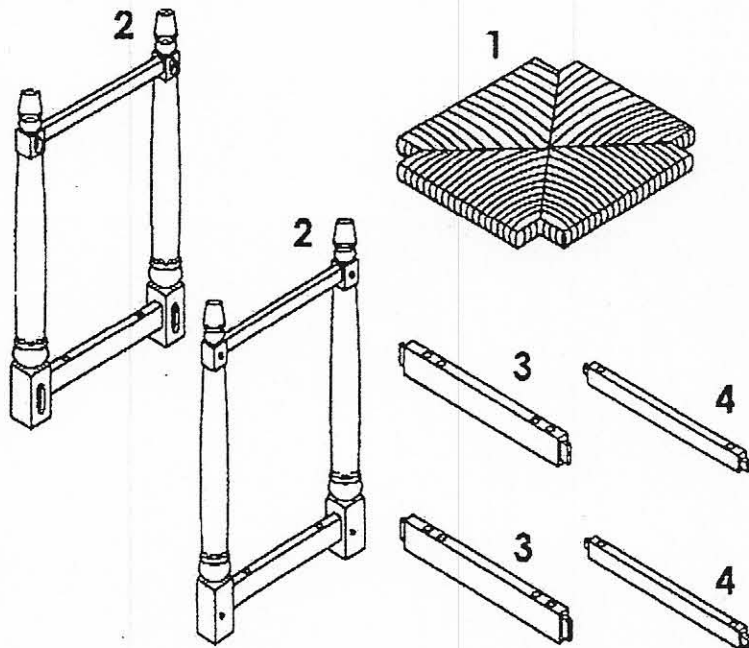
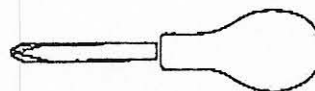
**TOOLS REQUIRED (NOT INCLUDED) :**

Philip Head Screw Driver

IMPORTANT NOTE :

- Place all wooden parts on a clean and smooth surface such as a rug or carpet to avoid the parts from being scratched. Check to be sure that you have all parts and hardware. Remove all wrapping materials, including staples & packing straps before you start to assemble. Do not tighten all screws/bolts until all completely assembled.
- Keep all hardware parts out of reach of children.
- **DO NOT TIGHTEN BOLTS/SCREWS UNTIL ALL COMPLETELY ASSEMBLED.**

MODEL NO. : Z66Z-K1A-AB/MW/WAL
24" RUSH SEAT STOOL

1

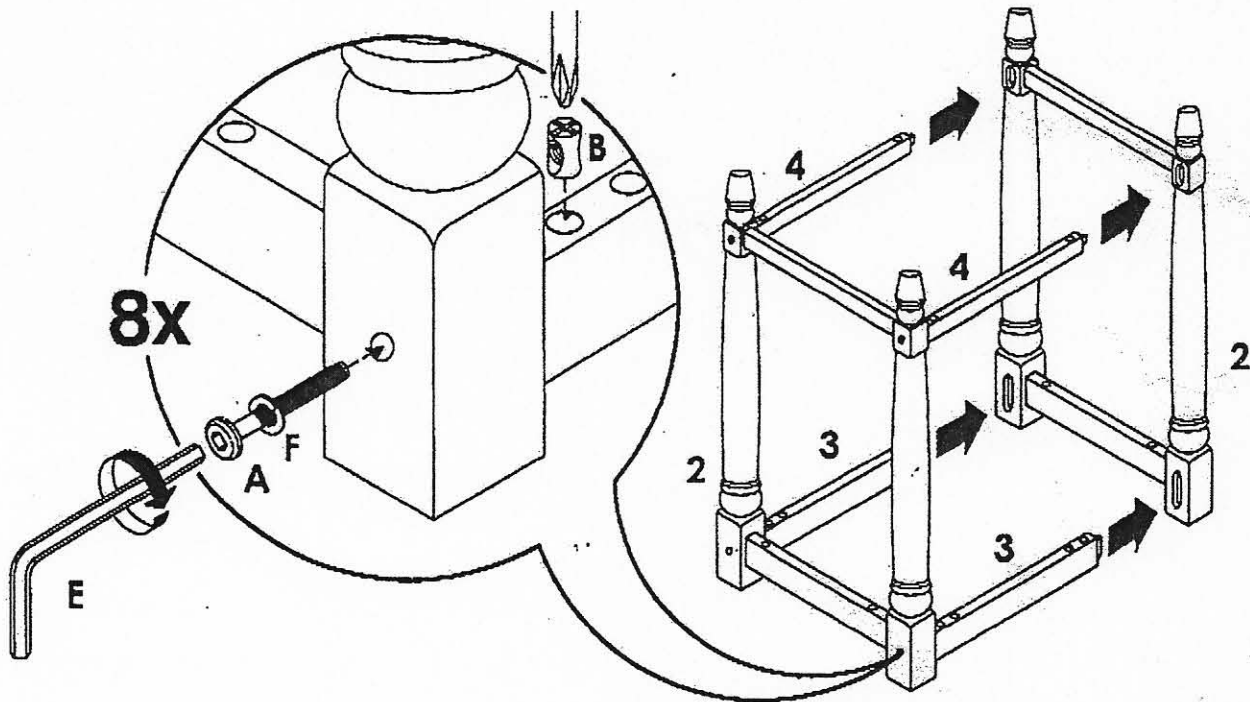

2

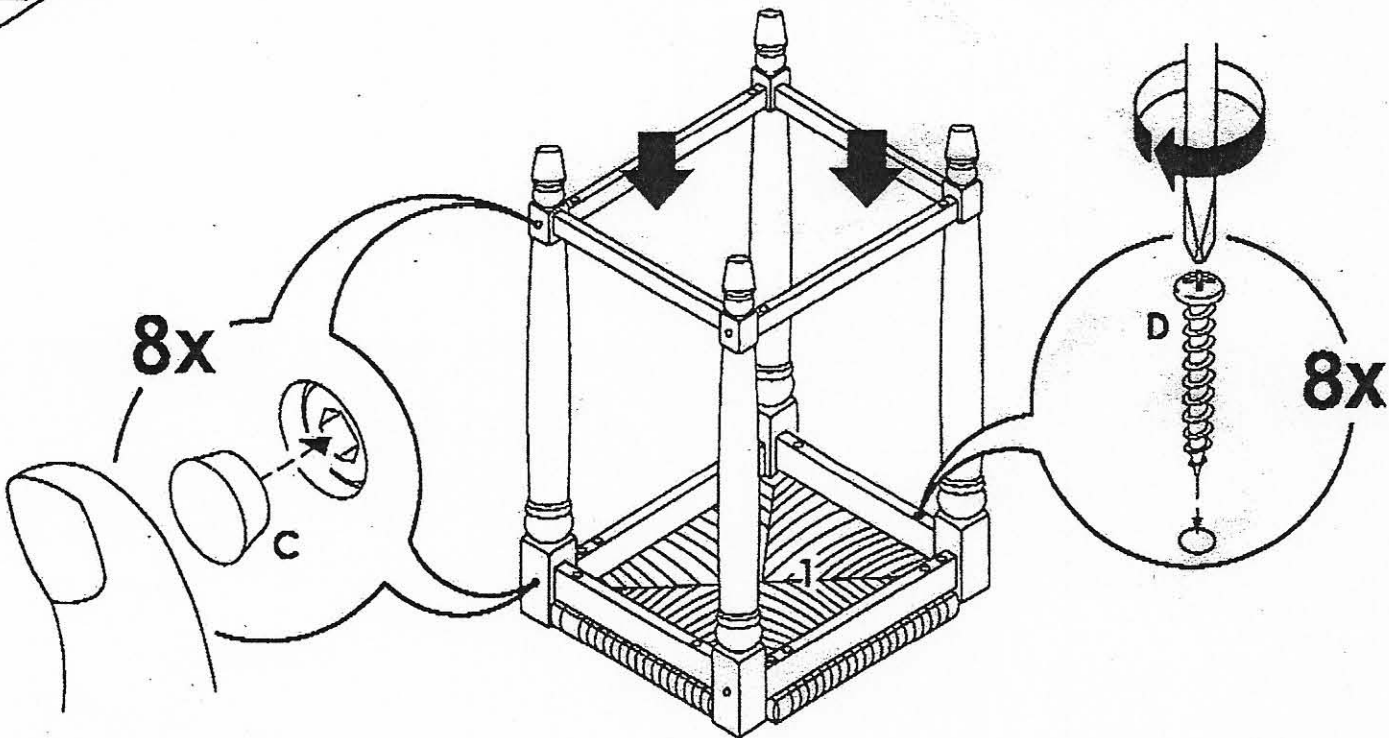

CARE AND MAINTENANCE

- The touch of a soft cloth is all the maintenance your wood pieces will ever need. Never use harsh chemicals or abrasive cleaners, as they could mark or destroy finish.
- Bolts, screws, and nuts may loosen during everyday use. They should be periodically inspected and re-tightened to prevent damage or injury. Always visually check that all hardware on the list is attached and kept tightened.

MADE IN MALAYSIA

CARE INSTRUCTIONS

Thank you for your purchase. Our items are intended for residential use only.

To clean and maintain your furniture we recommend dry dust with a soft clean cloth.

Do not use harsh chemicals to clean your furniture as this could damage the protective top coat and/or finish.