



USER'S MANUAL

SODA STORM™ SERIES BLASTERS



⚠️ WARNING

These products and equipment are not under any circumstances to be used with sand or silica products of any type and use of such materials will void any warranty. Also, as with the use of any product or equipment you must be sure to use the proper safety equipment and to properly train your employees in the use of any equipment or products. The manufacturer, wholesaler and distributor assume no responsibility arising from the failure to use proper safety equipment or the failure to properly train employees in the use of products and equipment.



⚠️ WARNING

Read Manual

Failure to read, understand & follow **all** safety and operation procedures in this manual can cause serious injury or death. Manuals that are lost, incomplete, or damaged must be replaced immediately.

Manual P/N: PB-MAS004



⚠️ USING THIS MANUAL ⚠️

Thank you for your purchase of a Pirate Brand® Soda Storm™ Blaster. It is important to note that all Pirate Brand® blasting equipment is designed to be safe when used properly, however, misuse of any abrasive blasting equipment is dangerous and can result in the severe injury or death of the operator and others in the vicinity of the blasting equipment. In order to protect yourself and those around you, read and follow all sections of this manual & warning labels located on the blasting equipment.

Definition Of Terms Used In This Manual

Abrasive: A granular material used for blasting the surface of an object. Also referred to as "Media."

Blow-down: The automatic or manual release of air from a pressurized vessel. Also referred to as "Depressurize."

Control Handle: A required device that allows the blaster to be remotely started and stopped.

Depressurize: The automatic or manual release of air from a pressurized vessel. Also known as "Blow-down".

Differential Pressure: A type of blasting in which a slightly higher pressure is achieved inside the pressure vessel to help "push" abrasive (like soda) through the metering valve.

Pressure Hold System: Any blasting system in which the Pressure Vessel remains pressurized when the control handle is released. Also known as a Manual Blow-down System. All Soda Storm™ Systems are Pressure Hold Systems.

Pressure Release System: Any blasting system in which the Pressure Vessel is automatically depressurized when the control handle is released. Also known as an Automatic Blow-down System.

Pressure Vessel: The enclosed area of the blaster in which abrasive is contained and filled with pressurized air when blasting.

Pressurize: To fill the pressure vessel with compressed air.

Properly Trained: A person who can be considered "properly trained" must have successfully completed a sandblasting training course that focuses on the safe operation of stationary or portable abrasive blasters in the 1.5 - 6.5 cu. ft. capacity range. They must also have read and understood this manual in its entirety.

Silica: A hazardous substance which is contained in many naturally occurring abrasives. Dust produced by blasting with abrasives containing silica can cause respiratory disease. Do not use abrasive containing silica under any circumstance, even when respiratory protective equipment is being used.

Safety Symbols

The safety symbols shown below exist for the safety and protection of the operator and those in the vicinity of the Abrasive Blaster. The descriptions below explain how they are used in relation to the blasting equipment.



OR



OR



WARNING: This symbol calls attention to a potentially hazardous situation that could result in serious injury or death if the instructions associated with the symbol are not followed. The warning triangle will be displayed throughout the manual to denote instructions to which special attention should be paid.

DANGER: This symbol calls attention to a potentially hazardous situation that **WILL** result in serious injury or death if the instructions associated with the symbol are not followed. The warning triangle will be displayed throughout the manual to denote instructions to which special attention should be paid.



WARNING

- All persons who will be operating or will be in the vicinity of the Abrasive Blaster during its operation must receive proper training on how to safely operate the equipment and be informed of the potential hazards involved. In addition to proper training, all persons who will be operating or will be in the vicinity of the Abrasive Blaster during its operation must read, understand and follow all procedures described in the user's manual. For replacement manuals, please contact your distributor or visit www.pirate-brand.com.
- Respiratory protection is mandatory for all persons operating or located in the vicinity of the Abrasive Blaster. Follow all OSHA and NIOSH requirements for breathing equipment and supplied air standards.
- Pressurized Vessels contain large amounts of stored energy and can cause severe injury or death if safety procedures are not followed. **Never** perform maintenance or attempt to open a Pressure Vessel for any reason while it is Pressurized. **Always** Depressurize and properly disconnect equipment from its air source before performing any maintenance. **Do not** modify, grind or weld on the pressure vessel for any reason. Doing so will void the ASME certification. **Do not** use damaged pressure vessels.
- The use of proper remote control systems (commonly referred to as Deadman controls) are required when using abrasive blasters. **Never** operate the Abrasive Blaster without remote controls. **Never** use bleeder type control handles, such as Clemco® or A-BEC® style handles, with SPH or SPR series blasters as they can cause a hazardous situation where the blaster will not shut off when the handle is released.
- All persons who will be operating or will be in the vicinity of the Abrasive Blaster during its operation must protect themselves with the proper safety equipment and use of common sense. Safety equipment including but not limited to Hearing, Eye, Body and Lung protection are required. Abrasive blasters and the objects being blasted can be heavy and can lead to severe injury or death if they fall over. Always follow all safety requirements of OSHA and NIOSH.
- Use only Genuine Pirate Brand® replacement parts when performing maintenance on the Abrasive Blaster. **Do not** modify the equipment for any reason. Use of modified or non-Pirate Brand® parts can cause an unsafe situation and will void your warranty.
- **Never** use malfunctioning or damaged equipment. Before each use, inspect the Abrasive Blaster for proper function.
- Supply only cool, dry, compressed air that is free of debris to the Abrasive Blaster. Moisture or debris that reaches the remote control system can cause an unsafe situation. **Do not** supply compressed air to the blaster that exceeds 150 PSI.
- **Do not** use abrasive blasters in areas that could be considered a hazardous location as described in the National Electric Code NFPA 70, Article 500. **Never** use the Abrasive Blaster in wet environments. **Always** connect electrically controlled abrasive blasters to a Ground Fault Circuit Interrupter (GFCI).



☠ TABLE OF CONTENTS ☠

Using This Manual	2
Definition Of Terms	2
Safety Symbols	2
WARNINGS	3
How Soda Storm Systems Work	5
SUCCESSFUL SODA BLASTING	6
Steps To Effective Soda Blasting	6
Achieving Optimal Flow Rates	7
Safety Label Information	8
OPERATING PROCEDURES	10
Set-Up	10
Before You Blast	11
Blasting	12
MAINTENANCE PROCEDURES	14
TROUBLESHOOTING	16
Warranty	18
Pressure Vessel Parts Lists	19
Pipe String Parts Lists	20
1.5 cu ft Soda Storm	20
3.5 cu ft Soda Storm	22
6.5 cu ft Soda Storm	24
Abrasive Cut-Off Controls	26
Control Handle Parts Lists	28
Valve Parts Lists	28
Blasting Set-Up	30
Available Accessories	31
Blasting Chart	32



Distributed By:



Contact Info:

For manual updates visit the
Pirate Brand® website at:

WWW.PIRATE-BRAND.COM



HOW SODA STORM™ SYSTEMS WORK

WARNING: This section of the manual is designed to give you a general understanding of how the Abrasive Blaster functions. **All** sections of this manual must be read and understood before operating the equipment.

ADDING ABRASIVE

Abrasive is added through the hole in the top of the Abrasive Blaster where the Pop-up and its seat are located. When abrasive is added, it flows down through the opening, around the Pop-up, and down to the bottom of the pressure vessel where it will exit through the Multi-Port Fixed Orifice Sleeve in the Metering Valve when blasting is started.

PRESSURIZATION

Before pressurization can take place in a Soda Storm™ system, the Blow-down Valve must be closed. Then, when a compressed air source (such as an air-compressor) is connected to the inlet of the Abrasive Blaster and the Inlet Valve is opened, compressed air can flow through the Moisture Separator/Filter and Pressure Regulator into the pressure vessel causing the Pop-up (located internally) to seal against its seat allowing the pressure vessel to become pressurized. To blast at pressures less than the minimum required inlet pressure of 90 PSI, the Pressure Regulator is used. When the control handle is activated, the Auto Air Valve and Metering Valve open allowing compressed air & abrasive to flow and mix. The mixture of compressed air and abrasive will now exit the Abrasive Blaster through a blast hose and nozzle connected to the coupling on the Metering Valve and blasting begins.

DIFFERENTIAL PRESSURE

When blasting using the Multi-Port Fixed Orifice Sleeve in the Metering Valve, differential pressure may be used to aid in the flow of abrasive. Differential pressure uses **slightly** higher pressure in the Pressure Vessel than in the Pusher Line to help "push" the abrasive through the small orifices in the Multi-Port Fixed Orifice Sleeve. Differential pressure is achieved by partially closing the Differential Pressure Gate Valve until the Differential Pressure Gauge is reading a **slightly** lower PSI than the Vessel Pressure Gauge. In addition to using differential pressure, the Vibrator may be used to aid in the flow of abrasive.

DEPRESSURIZATION (BLOW-DOWN)

When the control handle is released in a pressure hold (SPH) system, the pressure vessel remains filled with compressed air. The compressed air remaining in the pressure vessel is released when the inlet valve is manually closed and the blow-down valve is manually opened.

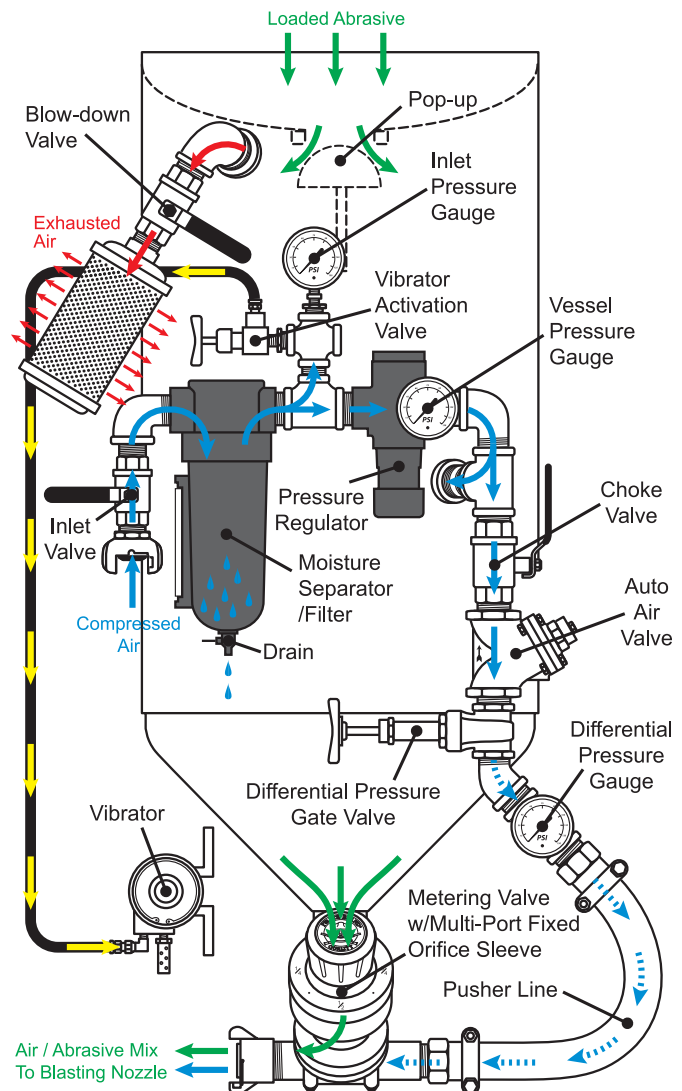
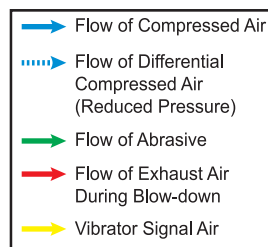



SUCCESSFUL SODA BLASTING



(STEPS TO EFFECTIVE SODA BLASTING)



WARNING: This section of the manual is designed to give you a general understanding of how to effectively blast with soda. **All** sections of this manual must be read and understood before operating the equipment.

Blasting with soda and soda-blasting machines is a different process than blasting with standard “sand” blasting media and equipment. The following steps outline the soda blasting process and will serve as a general guide to successful soda blasting.

1. Supply the equipment with clean, cool & dry air at 90-150PSI.

Moisture in the air supply will cause the blasting media to clump causing blockages and costly downtime. It is highly recommended that an air dryer be used to ensure moisture does not enter the blasting equipment.

2. Use a screen.

Foreign materials (including pieces of the bag the soda is packaged in) will clog the metering valve resulting in costly downtime. Always pour the blasting media through the included screen to prevent foreign materials from entering the equipment.

3. Fully open the metering valve.

When using the soda machine with a multi-port fixed orifice sleeve (equipped this way from the factory) it is important to blast with the metering valve completely open. To do this turn the knob on the metering valve clockwise until it stops, then turn it counterclockwise 9 full turns to ensure it is fully open.

4. Set the regulator.

While a supply of at least 90 PSI is recommended to operate the abrasive blaster, soda blasting is usually performed at a lower pressure. Use the included regulator to lower the blasting pressure to the desired PSI using procedures described in the “Operating Procedures” section of the manual.

5. Use the vibrator.

The vibrator aids in the flow of soda through the abrasive blaster. Open the Vibrator Activation Valve 1/4 to 1/2 turn to activate the vibrator.

6. Set differential pressure.

Differential pressure (slightly increased pressure in the pressure vessel) helps to “push” soda through the small orifices of the Multi-Port Fixed Orifice sleeve in the Metering Valve. Differential pressure is achieved by partially closing the Differential Pressure Gate Valve until the Differential Pressure Gauge reads 2-4 PSI lower than the Vessel Pressure Gauge when blasting. See the “Operating Procedures” section of the manual for more details.

7. Check and adjust flow-rate using “Bag Test” method.

Setting-up soda blasting equipment to achieve an optimal flow rate is essential for getting efficient productivity from the soda you have purchased. Operating soda blasting equipment that is set-up with a flow rate that is too high or too low will result in poor performance and an expensive waste of blasting soda. See the “Successful Soda Blasting - Achieving Optimal Flow Rates” section of the manual for details on checking and adjusting the flow rate.

8. Use a water induction nozzle to reduce dust.

By using a water induction nozzle such as the WIN® System, the amount of air-borne dust will be reduced when blasting with soda. (see the “Blasting Set-up” section of the manual WIN® System Information)



☠ SUCCESSFUL SODA BLASTING ☠ (ACHIEVING OPTIMAL FLOW RATES)



WARNING: This section of the manual is designed to give you a general understanding of how to set-up a Soda Storm™ Blaster to achieve effective soda flow rates. **All** sections of this manual must be read and understood before operating the equipment.

Setting-up soda blasting equipment to achieve an optimal flow rate is essential for getting efficient productivity from the soda you have purchased. Operating soda blasting equipment that is set-up with a flow rate that is too high or too low will result in poor performance and an expensive waste of blasting soda. In this section of the manual, we will explain how to set-up and test the flow rate of your Soda Storm™ Blaster.

Note: The following procedure assumes a typical soda blasting application in which the optimal flow rate is 3 lb/min at a blasting pressure of 60 PSI. Contact your soda supplier to obtain optimal flow rates and pressures for specific soda products and applications.

PERFORMING THE “BAG TEST”

1. Load the blaster with one 50 lb bag of soda.
2. Following all procedures and safety recommendations found in the “Operating Procedures” of this manual, set the regulator to achieve a vessel pressure of 60 PSI, and open the vibrator activation valve 1/4 to 1/2 turn to start the vibrator.
3. Begin blasting and immediately have a second person adjust the differential pressure gate valve so the differential pressure gauge reads 2-4 PSI lower than the vessel pressure gauge achieving 2-4 PSI of differential pressure.
4. Continue to blast **without stopping** until the 50 lbs of soda have been completely exhausted and record the total blasting time taken to use all 50 lbs. (We recommend the use of a Job Timer to aid in keeping track of blasting times. See the “Available Accessories” section of this manual for details.)
5. Divide the 50 lbs of media by the time you recorded to get the final flow rate. For Example:

$$\frac{50 \text{ lbs}}{16\frac{2}{3} \text{ min}} = 3 \text{ lbs/min}$$

ADJUSTING THE FLOW RATE

Once you have determined your flow rate, you may find that it needs to be adjusted. To reduce the flow rate, reduce the differential pressure being used. To increase the flow rate, increase the differential pressure being used. We recommend staying within 2-4 PSI of differential pressure. If you find that your rate is still too high even when running only 2 PSI of differential pressure, you will need to switch to a smaller orifice in your metering valve. Conversely, if your rate is still too low even when running at 4 PSI of differential pressure, you will need to switch to a larger orifice in your metering valve. After making adjustments, repeat the bag test to calculate your new flow rate.

WHEN TO PERFORM THE “BAG TEST”

The flow rate should be recalculated and adjusted whenever the blaster is set up in a new location, a new abrasive is being used, the air supply has changed, or the blasting pressure has changed. In applications where the blaster will be used in a single location, it is recommended that the flow rate be recalculated at least once per week to ensure an efficient use of media.

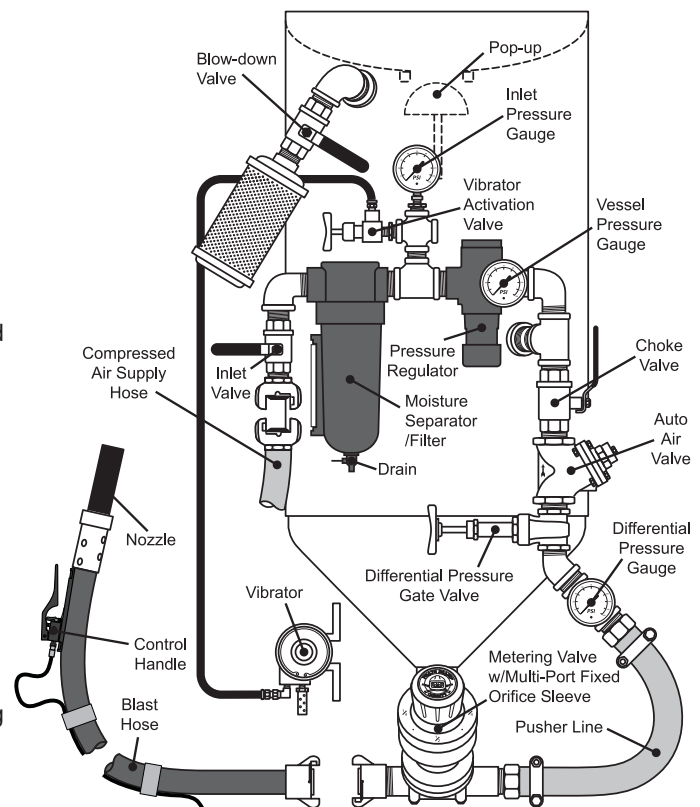



SODA STORM™ BLASTERS - USER'S MANUAL



WARNING LABEL LOCATIONS



(1.5 CU FT VESSELS)

- 1 - Explosion Hazard
 - 2 - Severing Hazard (X2)
 - 3 - Read Manual
 - 4 - Crush Hazard
 - 5 - Drain Label
 - 6 - Breathing Hazard
 - 7 - Hearing Hazard
 - 8 - Eye Hazard
 - 9 - Pressurized Hose
 - 10 - Spray Hazard
 - 11 - **WARNING** Label
 - 12 - Made In USA
 - 13 - Series Label
 - 14 - Inlet Label
 - 15 - Outlet Label
 - 16 - 6" Pirate Brand® Label*
 - 17 - Soda Storm™ Label*
- * Ordered Separately

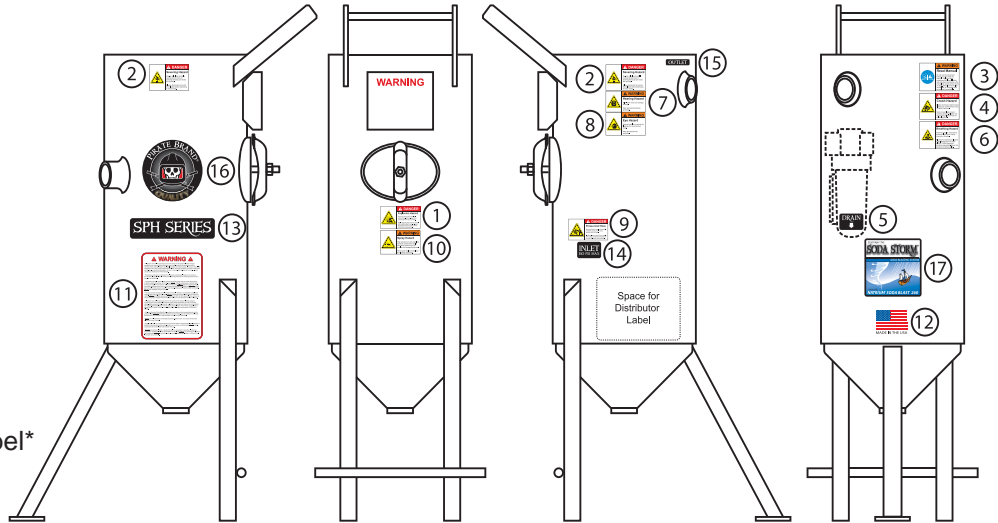

Labels must be replaced when they are no longer readable!

Replacement Label Pack P/N: PB-LPS003



Instructions For Installing Replacement Label Pack

1. Completely remove old label and clean area thoroughly before applying new label.
2. Apply replacement labels in locations as described above or as close as possible if area is obstructed.
3. The label pack may contain labels intended for other models of equipment. Do not install labels from the label pack that are not shown in the above numbered drawing.



WARNING LABEL LOCATIONS

(3.5 & 6.5 CU FT VESSELS)

- 1 - Explosion Hazard (X2)
 - 2 - Severing Hazard (X2)
 - 3 - Read Manual
 - 4 - Crush Hazard
 - 5 - Drain Label
 - 6 - Breathing Hazard
 - 7 - Hearing Hazard
 - 8 - Eye Hazard
 - 9 - Pressurized Hose
 - 10 - Spray Hazard
 - 11 - **WARNING** Label
 - 12 - Made In USA
 - 13 - Series Label
 - 14 - Inlet Label
 - 15 - Outlet Label
 - 16 - 12" Pirate Brand® Label*
 - 17 - Soda Storm™ Label*
- * Ordered Separately

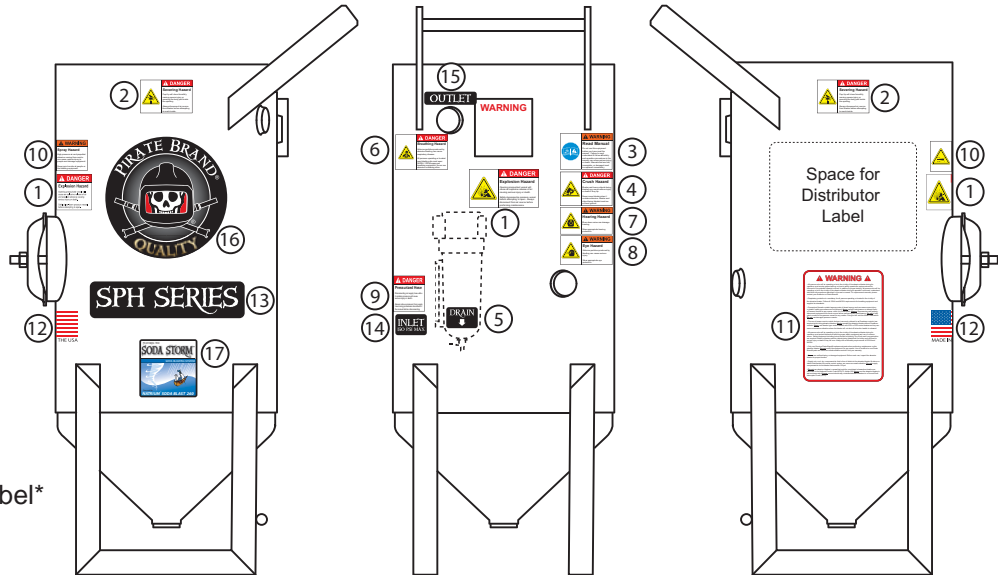

Labels must be replaced when they are no longer readable!

Replacement Label Pack P/N: PB-LPS001

SPH SERIES

SPR SERIES

DRAIN

↓

INLET
150 PSI MAX

12 VDC

OUTLET

MADE IN THE USA

See Manual for Label Placement Instructions
P/N: PB-LPS001 Sheet 1 of 4

WARNING

All persons operating or located near blasting site must wear NIOSH / OSHA approved hearing equipment. Never use abrasive containing silica.

<p style="text-align: center; font-weight: bold; color: red;">DANGER</p> <p style="text-align: center; font-weight: bold;">Severing Hazard</p> <p style="font-size: 0.8em;">Pop-Up will close forcefully causing serious injury or severing the body part inside the opening.</p> <p style="font-size: 0.8em;">Always disconnect air source from blaster before attempting to reach inside. See manual for proper procedures.</p>	<p style="text-align: center; font-weight: bold; color: red;">DANGER</p> <p style="text-align: center; font-weight: bold;">Severing Hazard</p> <p style="font-size: 0.8em;">Pop-Up will close forcefully causing serious injury or severing the body part inside the opening.</p> <p style="font-size: 0.8em;">Always disconnect air source from blaster before attempting to reach inside. See manual for proper procedures.</p>
<p style="text-align: center; font-weight: bold; color: red;">WARNING</p> <p style="text-align: center; font-weight: bold;">Read Manual</p> <p style="font-size: 0.8em;">Do not use this equipment before you have read the manual. Failure to read, understand & follow safety and operation procedures in the manual can cause serious injury or death. Manuals that are lost, inaccurate, or damaged must be replaced immediately.</p>	<p style="text-align: center; font-weight: bold; color: red;">DANGER</p> <p style="text-align: center; font-weight: bold;">Crush Hazard</p> <p style="font-size: 0.8em;">Blaster and heavy objects being blasted can tip causing serious injury or death.</p> <p style="font-size: 0.8em;">Never move blaster when it contains abrasive. Blaster and object being blasted must be on level ground.</p>

P/N: PB-LPS001 Sheet 2 of 4

<p style="text-align: center; font-weight: bold; color: red;">DANGER</p> <p style="text-align: center; font-weight: bold;">Explosion Hazard</p> <p style="font-size: 0.8em;">Ongoing production of dust will cause explosion. Never use in enclosed areas. Always disconnect air source from blaster before attempting to reach inside. See manual for proper procedures.</p>	<p style="text-align: center; font-weight: bold; color: red;">DANGER</p> <p style="text-align: center; font-weight: bold;">Explosion Hazard</p> <p style="font-size: 0.8em;">Ongoing production of dust will cause explosion. Never use in enclosed areas. Always disconnect air source from blaster before attempting to reach inside. See manual for proper procedures.</p>	<p style="text-align: center; font-weight: bold; color: red;">DANGER</p> <p style="text-align: center; font-weight: bold;">Pressurized Hose</p> <p style="font-size: 0.8em;">Disconnecting or using hose while blaster is in operation can cause serious injury or death. Always disconnect air source from blaster before attempting to reach inside. See manual for proper procedures.</p>
<p style="text-align: center; font-weight: bold; color: red;">WARNING</p> <p style="text-align: center; font-weight: bold;">Exhaust Hazard</p> <p style="font-size: 0.8em;">Blaster will disintegrate without warning when operator releases remote control. Unsecured hose and objects propelled by exhauster or can cause serious injury or death.</p> <p style="font-size: 0.8em;">Never stand near exhaust hose when blaster is in operation. Secure exhaust hose to a stationary surface if it extends more than 12' from valve.</p>	<p style="text-align: center; font-weight: bold; color: red;">WARNING</p> <p style="text-align: center; font-weight: bold;">Spray Hazard</p> <p style="font-size: 0.8em;">High pressure air and propelled abrasive coming from nozzle can cause serious injury to people and damage equipment.</p> <p style="font-size: 0.8em;">Never point nozzle at people or the blasting equipment.</p>	<p style="text-align: center; font-weight: bold; color: red;">WARNING</p> <p style="text-align: center; font-weight: bold;">Eye Hazard</p> <p style="font-size: 0.8em;">Airborne particles produced by blasting can cause serious injury.</p> <p style="font-size: 0.8em;">Wear appropriate eye protection.</p>
<p style="text-align: center; font-weight: bold; color: red;">DANGER</p> <p style="text-align: center; font-weight: bold;">Breathing Hazard</p> <p style="font-size: 0.8em;">Airborne particles produced by abrasive blasting can cause respiratory disease.</p> <p style="font-size: 0.8em;">All persons operating or located near blasting site must wear NIOSH / OSHA approved breathing equipment. Never use abrasive containing silica.</p>	<p style="text-align: center; font-weight: bold; color: red;">WARNING</p> <p style="text-align: center; font-weight: bold;">Hearing Hazard</p> <p style="font-size: 0.8em;">Noise generated by abrasive blaster can damage hearing.</p> <p style="font-size: 0.8em;">Wear appropriate hearing protection.</p>	<p style="text-align: center; font-weight: bold; color: red;">WARNING</p> <p style="text-align: center; font-weight: bold;">Hearing Hazard</p> <p style="font-size: 0.8em;">Noise generated by abrasive blaster can damage hearing.</p> <p style="font-size: 0.8em;">Wear appropriate hearing protection.</p>

P/N: PB-LPS001 Sheet 3 of 4

Instructions For Installing Replacement Label Pack

1. Completely remove old label and clean area thoroughly before applying new label.
2. Apply replacement labels in locations as described above or as close as possible if area is obstructed.
3. The label pack may contain labels intended for other models of equipment. Do not install labels from the label pack that are not shown in the above numbered drawing.



OPERATING PROCEDURES



WARNING: The Procedures provided in the Operating Procedures section of the manual are designed to provide basic information on how to safely operate the features of Pirate Brand® Soda Storm™ Series Abrasive Blasters. Only personnel thoroughly trained in abrasive blasting should operate the Abrasive Blaster.

SETTING-UP THE BLASTER

INSPECT PRESSURE VESSEL

When you receive your Abrasive Blaster, remove the Handway Assembly and check for foreign items that may have fallen into the Abrasive Blaster through the Pop-up opening. Remove any foreign materials and reinstall the Handway Assembly.



DANGER: Never perform any maintenance or attempt to open the Abrasive Blaster in any way while it is pressurized. The violent release of compressed air and propelled objects will cause serious injury or death.

RE-TIGHTEN HANDWAY ASSEMBLY

After the Abrasive Blaster has been pressurized for the first time, tighten the nut on the Handway Assembly. Tightening the nut on the Handway Assembly should also be done any time after the handway has been removed for maintenance before and after the next pressurization.



DANGER: Never perform any maintenance or attempt to open the Abrasive Blaster in any way while it is pressurized. The violent release of compressed air and propelled objects will cause serious injury or death.

CHOOSE SLEEVE/ORIFICE SIZE

Soda Storm™ Abrasive Blasters come with two interchangeable sleeves for the Metering Valve. One sleeve is the standard abrasive blasting sleeve used in our non-Soda Storm™ SPR/SPH Series Blasters. The other is a Multi-Port Fixed Orifice Sleeve used for effective cost control when blasting with a one-shot (single use) abrasive like soda. Soda Storm™ Abrasive Blasters come factory set with the Multi-Port Orifice Sleeve installed and set at the .125" orifice. This factory setting is the most commonly used setting for blasting with soda. The other orifice sizes that are available on the Multi-Port Fixed Orifice Sleeve are .157"/.180"/.209". Choose the sleeve/orifice size appropriate for the type of media and blasting application you will be using.

To change sleeves or orifice size, the Sleeve must be removed which requires some disassembly of the Metering Valve. Making sure the Abrasive Blaster is depressurized, remove the 4 bolts from the base of the valve. Next remove the base, pipe nipple, o-ring, insert & urethane seat (see pg. 29 #s17-21) to expose the sleeve. If

the sleeve comes out easily, remove it. If the sleeve will not come out easily, the cap must be removed so the plunger can be moved out of the way.



WARNING: Use caution when removing the Metering Valve cap as it is holding back a compressed spring. The cap may fly off when it is unscrewed.

With the cap removed, slowly push the plunger back until the orifice(s) in the sleeve are exposed but no farther. If the plunger is pushed past the seals, complete disassembly and reassembly of the valve may be necessary. Use a tool such as a pick to hook onto the orifice and gently work the sleeve out.

Reinstall the sleeve with a different orifice selected or with a new sleeve making sure the notch in the sleeve lines up with the corresponding alignment pin in the valve body. The orifice opposite of the alignment pin will be the one used for metering. Reassemble all components making sure not to overtighten any bolts. Do not use an impact wrench.

PURGE AIR SUPPLY HOSE

Before connecting the Air Supply Hose to the Abrasive Blaster, purge the hose of any moisture or foreign debris. Standing water or moisture in the air line will cause degraded performance of the Abrasive Blaster. Air supplied to the Abrasive Blaster must be clean, dry and cool.

ATTACH REMOTE CONTROL HANDLE

Attach the Remote Control Handle to the Blast Hose near the Nozzle with hose clamps or heavy wire ties. Form a loop of Twinline that comes 6" away from the Blast Hose, runs 6" parallel to the Blast Hose, and comes 6" back to the Blast Hose. Using duct tape, attach the Twinline to the Blast Hose where the loop ends by wrapping the tape around the Twinline twice and then around the Blast Hose. This creates a strain-relief attachment and is only necessary on the first connection near the Control Handle. Starting from the Nozzle end of the Blast Hose, attach the Twinline to the blast hose by wrapping duct tape around both every 3 feet.

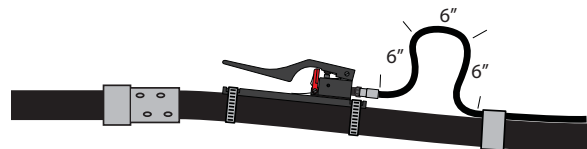



OPERATING PROCEDURES

BEFORE YOU BLAST

PRE-BLAST CHECK

Before each use of the Abrasive Blaster, it must be checked to ensure it is in a safe condition to be used. Closely examine all components of the Abrasive Blaster for signs of excessive wear, worn out seals and hoses, or damaged components. If any component of the Abrasive Blaster is found to be damaged or worn, it must be replaced before blasting.



WARNING: Never use an Abrasive Blaster if any components are damaged or worn. Damaged or worn parts must be replaced before use.

ADDING ABRASIVE

Before filling the Abrasive Blaster, make sure the inlet valve is closed and the pressure vessel is in a depressurized state. Abrasive is added by pouring it into the top of the Abrasive Blaster where it can flow around the Pop-up and into the pressure vessel. Do not overfill the Abrasive Blaster. Do not allow foreign materials to enter the Abrasive Blaster. It is recommended that a screen be used to prevent foreign objects from entering the Abrasive Blaster.



DANGER: Never reach into the Pop-up opening while filling the Abrasive Blaster. It can close without warning causing severe injury or death.



WARNING: Pirate Brand® Abrasive Blasters may not be used with abrasives containing silica. Never use abrasives containing silica.



WARNING: Never fill the abrasive blaster with the inlet valve in the open position. Always close the inlet valve before filling.



WARNING: Do not use electric remote controls (electric deadman controls) with Soda Storm™ Series Equipment.



WARNING: Never attempt to move or transport the Abrasive Blaster when it contains Abrasive.

REMOTE CONTROL SYSTEM

Abrasive Blasters must use a Remote Control System (commonly known as a deadman) to start and stop abrasive blasting. Soda Storm™ Systems use a pneumatic Remote Control System.

Connect the Remote Control twinline hose to

the Abrasive Blaster using the supplied quick-disconnect fittings. The twinline hose is supplied with different size fittings on each of the 2 lines to prevent them from being connected to the Abrasive Blaster incorrectly. Do not modify or reverse these fittings. It is recommended that Blast Hose/ Remote Control Twinline Hose runs do not exceed 100 feet.



WARNING: Never operate the Abrasive Blaster without a Remote Control System.



WARNING: Never use bleeder type Remote Control Handles such as Clemco® or A-BEC® style handles with Pirate-Brand® Soda Storm™ Series equipment as they may cause the Abrasive Blaster to start without warning or to not stop the Abrasive Blaster when released.



WARNING: Never reverse or modify pneumatic Remote Control twinline hose fittings.

CONNECTING HOSES

Before connecting hoses to the Abrasive Blaster, make sure the Inlet Valve is closed and the compressed air supply is shut off. Connect the hose coming from the compressed air supply to the inlet on the Abrasive Blaster and secure with safety clips. Connect the blast hose to the coupling on the Metering Valve at the base of the Abrasive Blaster and secure with safety clips .



WARNING: Always use safety devices like clips and whip-checks (safety cables) at hose connections.

See page 13 for diagram of blaster components

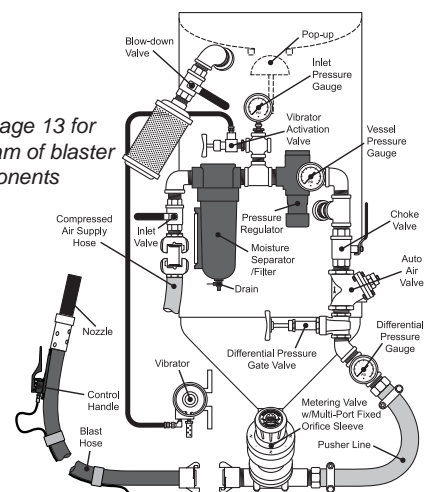



OPERATING PROCEDURES

BLASTING

PRESSURIZING THE ABRASIVE BLASTER

Before pressurizing the Abrasive Blaster make sure the following conditions occur:

- ☞ All "BEFORE YOU BLAST" procedures have been followed.
- ☞ The Inlet Valve is closed.
- ☞ The Blow-down Valve is closed.
- ☞ The Clean-out Ball Valve on the Metering Valve is closed.
- ☞ The Differential Pressure Gate Valve is completely open.
- ☞ The Vibrator Activation Valve is closed.
- ☞ The Remote Control Handle is released.
- ☞ All hose connections are secure and have a safety clip installed.
- ☞ The Abrasive Blaster is set up in a safe and level location where all people in the vicinity are aware of its presence.
- ☞ All necessary safety equipment is present and being worn by all people in the vicinity of the Abrasive Blaster.
- ☞ Only personnel who have been thoroughly trained and have read and understand the manual are in the vicinity of the Abrasive Blaster.

When these conditions are met, turn on the compressed air source and open the Inlet Valve on the Abrasive Blaster. The Abrasive Blaster is now ready to begin blasting.



DANGER: Never perform any maintenance or attempt to open the Abrasive Blaster in any way while it is pressurized. The violent release of compressed air and propelled objects will cause serious injury or death.



DANGER: Never supply compressed air exceeding 150 PSI (10.3 BAR) to the Abrasive Blaster. (125 PSI Max when using nylon couplings)



DANGER: Never operate the Abrasive Blaster with the Clean-out Ball Valve on the Metering Valve in the open position.



WARNING: Blast Hose may kick back when Remote Control Handle is activated. Be prepared and brace yourself for kick back.



WARNING: All those who will be in the area while blasting is to occur must be properly trained, read the manual, and be wearing safety equipment to protect from the hazards described by the WARNING and DANGER labels located on the Abrasive Blaster. If any labels are worn or missing they must be replaced. See the "Warning Labels Location" section for details.

USING THE ABRASIVE BLASTER

When using the Multi-Port Fixed Orifice sleeve and differential pressure:

Close the Metering Valve completely by turning the knob clockwise until it no longer turns then turn it counter-clockwise 9 full turns to ensure the fixed orifice in the sleeve will be completely unobstructed. With this procedure complete and the blaster pressurized, it is ready to begin blasting and setting your regulated pressure and differential pressure.

Press safety button or push down safety flap and squeeze the Remote Control Handle to start the flow of abrasive and compressed air. Adjust the Pressure Regulator (if necessary) until the desired blasting pressure is shown on the Vessel Pressure Gauge. Check to make sure the Vessel Pressure Gauge and the Differential Pressure Gauge are showing the same pressure. If they are not, do not continue with blasting and see the "Troubleshooting" section of this manual. Close the Differential Pressure Gate Valve until the reading on the Differential Pressure Gauge is 2-4 PSI lower than the Vessel Pressure Gauge to achieve differential pressure to aid in the flow of abrasive through the Multi-Port Fixed Orifice Sleeve. For more information on achieving the optimal flow rate of soda see the "Successful Soda Blasting - Achieving Optimal Flow Rates" section of this manual.

Lastly, open the Vibrator Activation Valve 1/4 to 1/2 turn to start the vibrator and further aid in the flow of abrasive through the Multi-Port Fixed Orifice Sleeve. Opening the Vibrator Activation Valve more than what is necessary to get the vibrator to start working will not aid in the flow of abrasive and will result in excessive wear of the vibrator.

To stop the flow of compressed air and abrasive, release the Remote Control Handle and blasting will stop after a short time. How long it takes for blasting to stop will depend on the length of Blast Hose being used.

When using the standard sleeve without differential pressure:

After pressurizing the Abrasive Blaster, it is ready to begin blasting. Press safety button or push down safety flap and squeeze the Remote Control Handle to start the flow of abrasive and compressed air. Adjustments to the air/abrasive mixture can be made by turning the handle on the Metering Valve. There will be a delay between a change made at the Metering Valve and what comes out of the Nozzle depending on the length of Blast Hose being used. Adjustments to the Metering Valve can only be made when Abrasive Blaster is not in operation.

To stop the flow of compressed air and abrasive, release the Remote Control Handle and blasting will stop after a short time. How long it takes for blasting to stop will depend on the length of Blast Hose being used.

(Dangers and Warnings for the above procedures continue on the next page)



OPERATING PROCEDURES

BLASTING



DANGER: Airborne particles produced by abrasive blasting can cause respiratory disease. All persons operating or located near the blasting site must wear approved NIOSH / OSHA approved breathing equipment. Never use abrasive containing silica.



WARNING: Never operate a Soda Storm™ Abrasive Blaster without a muffler on the Blow-down valve. Without the muffler, the sudden release of compressed air can cause severe injury.



WARNING: Only personnel thoroughly trained in abrasive blasting should operate the Abrasive Blaster. This manual only provides basic information on how to safely operate the features of Pirate Brand® Soda Storm™ Abrasive Blasters.



WARNING: Never point the blast Nozzle at yourself, other people, or the Abrasive Blaster.



WARNING: The Choke Valve must be completely open when blasting or damage to equipment will occur.

DISCONNECTING AIR SUPPLY HOSE

After the Abrasive Blaster has been depressurized, and the Inlet Valve has been closed, the Compressed Air Supply Hose may still contain pressure which must be released before disconnecting the hose. To do this shut off the compressed air at its source, and open the Drain Valve on the Abrasive Blaster. Slowly open the inlet valve on the Abrasive Blaster. The compressed air stored in the Compressed Air Supply Hose can now escape through the Drain Valve. When you no longer hear air escaping through the drain valve, squeeze the Compressed Air Supply Hose to confirm the absence of compressed air. After confirming the absence of compressed air in the Compressed Air Supply Hose it is ready to be disconnected.

USING THE WATER INDUCTION NOZZLE

The WIN® Nozzle may be used to reduce the amount of dust created when blasting with soda. To used the WIN® Nozzle, close the valve on the hose connector and connect a standard garden hose. When blasting, open the valve on the hose connector until the desired amount of water is injected into the abrasive stream.



DANGER: Never disconnect any compressed air supply hose without first performing the "DISCONNECTING AIR SUPPLY HOSE" procedure described above. Failure to do so can cause the hose to blow off violently injuring or killing nearby people.



WARNING: Check with the manufacturer of the abrasive you will be using for environmental and safety concerns. For example, soda can be detrimental to vegetation.

DRAINING THE MOISTURE SEPARATOR

During blasting, the Moisture Separator/Filter must be periodically drained. The best way to accomplish this is to leave the drain valve slightly open all the time so it constantly leaks air and forces moisture out.



WARNING: The Abrasive Blaster must be supplied with clean, cool, dry compressed air in order to function properly. The included Moisture Separator/Filter on the Abrasive Blaster may not be sufficient to achieve this depending on the quality of the air being supplied.

SHUTTING DOWN THE ABRASIVE BLASTER

When blasting is complete, the Abrasive Blaster will need to be shut down. Make sure the Remote Control Handle is released then close the Inlet Valve and Vibrator Activation Valve. To depressurize the Abrasive Blaster, slowly open the Blow-down Valve to allow the compressed air stored in the Abrasive Blaster to escape.

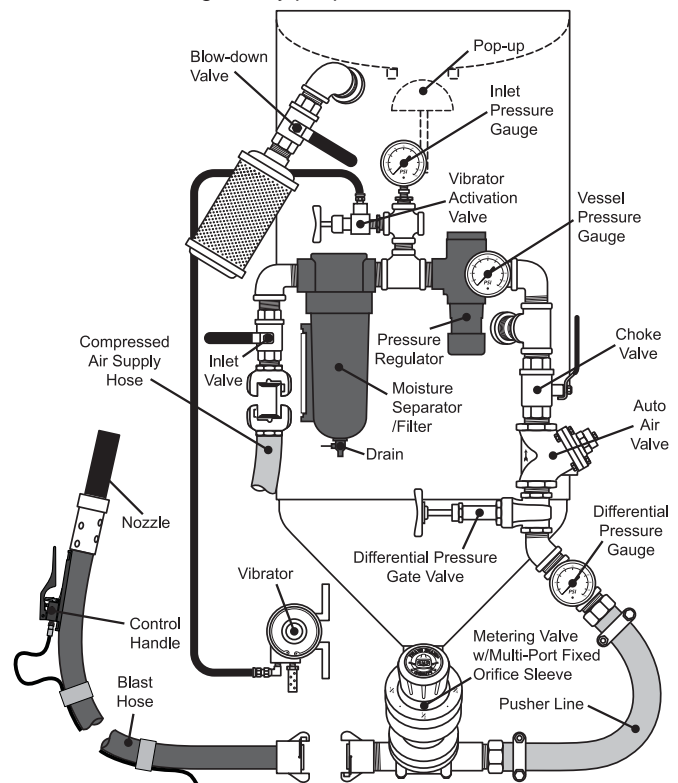



MAINTENANCE PROCEDURES



Maintenance Schedule



DANGER: Never perform any maintenance or attempt to open the Abrasive Blaster in any way while it is pressurized. The violent release of compressed air and propelled objects will cause serious injury or death.



WARNING: Maintenance procedures are to be performed by experienced qualified personnel only. Failure to perform maintenance procedures correctly at the intervals specified below can lead to performance problems and equipment failure, and will void the equipment warranty.

Procedure to be Performed	Maintenance Interval
1 Inspect Personal Protective Equipment (PPE) Including but not limited to: Respirators, Airline Filters, Carbon-Monoxide Monitors, Hearing Protection, Eye Protection, Foot Protection, Protective Clothing & Gloves. Reference www.osha.gov 29 CFR 1910.132 - General Requirements (PPE) 29 CFR 1910.133 - Eye (PPE) 29 CFR 1910.134 - Respiratory (PPE) 29 CFR 1910.136 - Feet (PPE) 29 CFR 1910.138 - Protective Clothing & Gloves (PPE) 26 CFR 1926.101 - Hearing (PPE)	Every 8 Hours Of Use
2 Inspect Remote Control Handles and Control Hose/Cord	Every 8 Hours Of Use
3 Inspect Blast Hose, Couplings & Gaskets	Every 8 Hours Of Use
4 Inspect Blasting Nozzle	Every 8 Hours Of Use
5 Inspect Air Hose, Couplings & Gaskets	Every 8 Hours Of Use
6 Inspect & Clean Blow-down Muffler	Every 40 Hours Of Use
7 Inspect Pop-Up & Pop-Up Gasket	Every 40 Hours Of Use
8 Service Metering Valve	Every 600 Hours Of Use
9 Service Auto Air Valve	Every 600 Hours Of Use
10 Service Control Valve(s)	Every 600 Hours Of Use

Descriptions of maintenance procedures referenced in this table are located on the next page.



MAINTENANCE PROCEDURES



Procedure Details

1. Inspect Personal Protective Equipment (PPE)

Inspect ALL Personal Protective Equipment (PPE) for proper fit, condition & operation as designed. Replace, repair, or be fitted as needed.

2. Inspect Remote Control Handles and Control Hose/Cord

Pneumatic Remote Control Systems:

Inspect Control Handle for damage making sure the Safety Flap/Lever Lock/Button is in good working order and replace or repair as needed. Inspect twinline hoses and replace if leaks, areas that show abrasion, or soft spots are found.

3. Inspect Blast Hose, Couplings & Gaskets

Inspect Blast Hose for leaks, abrasion & soft spots, and replace as needed. Inspect couplings for damage, leaks & wear, and replace as needed. Inspect coupling gaskets for leaks & wear, and replace as needed. Always use safety clips & whip checks (safety cables) at Blast Hose connections.

4. Inspect Blasting Nozzle

Inspect the Blasting Nozzle for wear and proper bore diameter. Replace the Blasting Nozzle when the bore diameter has worn to 1/16" wider than its original diameter. Example: replace a #5 nozzle (5/16" bore) when the bore reaches 3/8"

5. Inspect Air Hose, Couplings & Gaskets

Inspect Air Hose for leaks, abrasion & soft spots, and replace as needed. Inspect couplings for damage, leaks & wear, and replace as needed. Inspect coupling gaskets for leaks & wear, and replace as needed. Always use safety clips & whip checks (safety cables) at Air Hose connections.

6. Inspect & Clean Blow-down Muffler

Remove the Blow-down muffler, turn it upside-down and tap on a hard surface to free trapped debris. If muffler is clogged and can't be cleaned out sufficiently, it must be replaced.

7. Inspect Pop-Up & Pop-Up Gasket

Inspect the Pop-Up & Pop-Up Gasket for wear and replace as necessary.

8. Service Metering Valve

Disassemble, clean & inspect the Metering Valve for proper operation and worn components. Replace any worn components found. Lubricate APV & APVII valves with anti-seize before reassembling.

9. Service Auto Air Valve

Disassemble, clean & inspect for proper operation and worn components. Replace any worn components found. Lubricate with anti-seize before reassembling.

10. Service Control Valve(s)

Disassemble, clean & inspect for proper operation and worn components. Replace any worn components found. Lubricate with anti-seize before reassembling.



☠ TROUBLESHOOTING ☠

Performance Related Issues



DANGER: Never attempt to open the Abrasive Blaster in any way while it is pressurized. Use extreme caution when performing troubleshooting procedures that involve pressurizing the Abrasive Blaster. Troubleshooting procedures are to be performed by experienced qualified personnel only.

NO ABRASIVE FLOW WHEN BLASTING (AIR ONLY)

Possible Causes:

1. **The Abrasive Blaster is empty or has no Abrasive in it.**
2. **Abrasive cut-off function is engaged halting the flow of abrasive (if equipped).**
3. **The Metering Valve is closed or has not been adjusted properly.** If you are concerned the Metering Valve is not opening, the following test can be performed:

Close the Metering Valve fully by turning the knob clockwise until it stops, then turn the knob counter-clockwise about 9 full turns. Depress the control handle to start the blasting process and have a second person check to see if the knob is hard to turn or if it will not turn at all. If the knob is hard to turn or will not turn at all then the Metering Valve is opening properly.

4. **There is an obstruction in the Metering Valve.** To clear the obstruction perform the following procedure:

Turn the knob on the Metering Valve clockwise until it stops and then turn the knob counter-clockwise 9 full turns to open it completely. Depress the control handle and have a second qualified person close the choke valve for 2 seconds, and then open it again immediately. This will push minor obstructions such as a small amount of wet abrasive, a piece of paper from a bag, or bridged material through the Metering Valve and out the Nozzle. Readjust the Metering Valve back to the desired setting for blasting, and check to see if the obstruction has been cleared.

If the obstruction was not cleared by following the above procedure, slowly open the Clean-out Ball Valve on the metering valve about a quarter of the way while the vessel is pressurized. Leave the Clean-out Ball Valve open for a couple of seconds then close it completely. If successful, the obstruction, some abrasive & a jet of compressed air will be expelled from the open end of the Clean-out Ball Valve. Extra care should be taken to ensure the stream will not be directed at personnel or objects as they may be propelled at dangerous speeds.



WARNING: When the Clean-out Ball Valve is opened while the Abrasive Blaster is pressurized, abrasive, high-pressure air & nearby objects will be propelled from the open end of the valve. The area where this will occur must be free of personnel and structures/equipment or severe injury & damage to property may occur.

If trying to clear the obstruction with the Clean-Out Ball Valve fails, the Abrasive Blaster must be depressurized and the Metering Valve must be removed by separating the sanitary coupling that holds the Metering Valve to the Pressure Vessel. Be aware that when the obstruction is cleared, abrasive remaining in the Pressure Vessel will come pouring out. All abrasive must be allowed to leave the Pressure Vessel before reattaching the Metering Valve.

If all the above procedures fail to clear the obstruction, there is a large obstruction that must be removed from inside the Pressure Vessel. To do this, make sure the Abrasive Blaster is depressurized and remove the Handway Assembly. Scoop or vacuum out all the abrasive from inside the pressure vessel and remove the obstruction. Reinstall the Handway Assembly and Metering Valve and tighten them securely, then Refill the Abrasive Blaster.

It is recommended that a screen be used to prevent foreign objects from entering the Abrasive Blaster and causing an obstruction.

5. **The Abrasive Blaster has wet abrasive in it.** The wet abrasive must be removed by depressurizing the Abrasive Blaster, removing the Handway Assembly, and scooping or vacuuming it out.

Dry abrasive must always be used. Clean, cool, dry air must be supplied to the Abrasive Blaster in order to prevent the

abrasive from getting wet. For Abrasive Blasters being used outside, it is recommended that a lid be used to keep water from entering the Abrasive Blaster.

ABRASIVE STREAM IS TOO HEAVY OR THROBING WHEN BLASTING

Possible Causes:

1. **Choke Valve is partially closed.** Never run the Abrasive Blaster with the Choke Valve in any other position except fully open or damage to the Abrasive Blaster will occur.
2. **The Metering Valve needs to be adjusted.**
3. **Differential pressure is in excess of the recommended 4 PSI maximum.**

LOW PRESSURE AT THE NOZZLE

Possible Causes:

1. **Air compressor is the wrong size (too small) or the load button has not been pushed or turned on.**
2. **Nozzle is worn out and the compressor cannot keep up with the increased demand.**
3. **Air supply hose to the blast machine is too small.**
4. **There is a hole in the blast hose.**
5. **Pop-up is not sealing properly.**
6. **Handway Assembly is leaking.**
7. **Dirty or clogged Auto Air Valve Vent.**
8. **Diaphragm in Auto Air Valve is damaged, defective, or worn out.** To test, put your thumb over the vent. If any air is coming out with the control handle depressed, the diaphragm must be replaced.
9. **Choke Valve is partially closed.** Never run the Abrasive Blaster with the Choke Valve in any other position except fully open or damage to the Abrasive Blaster will occur.
10. **Abrasive Metering Valve is open too far (when using standard sleeve).**
11. **Obstruction in Nozzle.**
12. **Regulator needs adjustment.**

ABRASIVE BLASTER WILL NOT TURN ON OR IS SLOW TO TURN ON

Possible Causes:

1. **Air compressor is the wrong size (too small) or the load button has not been pushed or turned on.**
2. **Nozzle is worn out and the compressor cannot keep up with the increased demand.**
3. **Air supply hose to the blast machine is too small.**
4. **Control hoses and/or fittings are leaking.**
5. **50 micron Moisture Separator/Filter is clogged.**
6. **Obstruction in Nozzle.**
7. **Dirty or clogged Auto Air Valve Vent.**
8. **The Pneumatic Control Handle is damaged, defective or worn out.**
9. **Control Valve stuck or in need of service due to lack of lubrication, or is damaged, defective or worn out.**
10. **Diaphragm in Auto Air Valve is damaged, defective, or worn out (if equipped).** To test, put your thumb over the vent. If any air is coming out with the control handle depressed, the diaphragm must be replaced.



☠ TROUBLESHOOTING ☠

Operational Related Issues



DANGER: Never attempt to open the Abrasive Blaster in any way while it is pressurized. Use extreme caution when performing troubleshooting procedures that involve pressurizing the Abrasive Blaster. Troubleshooting procedures are to be performed by experienced qualified personnel only.

BLAST MACHINE TURNS ON ACCIDENTALLY OR WITHOUT WARNING

Possible Causes:

1. The safety flap, lever or lock button on the Control Handle is damaged or missing.
2. The Pneumatic Control Handle is damaged, defective or worn out.
3. A bleeder type control handle has been installed.



WARNING: Never use bleeder type Remote Control Handles such as Clemco® or A-BEC® style handles with Pirate-Brand® Soda Storm™ System as they may cause the Abrasive Blaster to start without warning or to not stop the Abrasive Blaster when released.

4. "O"-ring on the shaft of the Auto Air Valve is damaged, defective or worn out.

BLAST MACHINE IS SLOW TO TURN OFF OR WILL NOT TURN OFF WHEN CONTROL HANDLE IS RELEASED

Possible Causes:

1. A bleeder type control handle has been installed.



WARNING: Never use bleeder type Remote Control Handles such as Clemco® or A-BEC® style handles with Pirate-Brand® Soda Storm™ System as they may cause the Abrasive Blaster to start without warning or to not stop the Abrasive Blaster when released.

2. The Pneumatic Control Handle is damaged, defective or worn out.
3. The Control Valve is stuck or in need of service due to lack of lubrication, or is damaged, defective or worn out. (if equipped)

VESSEL PRESSURE AND DIFFERENTIAL PRESSURE GAUGES DO NOT AGREE

(Vessel Pressure and Differential Pressure Gauges should agree when the Pressure Vessel is pressurized and blasting is taking place with the Differential Pressure Gate Valve completely open.)

Possible Causes:

1. The Choke Valve is closed. Never operate the Abrasive Blaster with the Choke Valve in any other position than completely open.
2. The Differential Pressure Gate Valve is partially closed. The Differential Pressure Gate Valve must be completely open when comparing gauges for matching values.
3. One of the gauges is damaged, defective or worn out and needs to be replaced. Depressurize the Abrasive Blaster and swap the Differential Pressure Gauge with the Vessel Pressure Gauge. If the reading discrepancy follows the gauge to its new location, install a new gauge and keep the existing gauge that agrees with the new one. If the readings stay the same at the same positions, then the gauges are working properly and the problem is not with the gauges.
4. The Auto Air Valve is not opening fully. Check for proper

operation of the Auto Air Valve, and that its vent is not clogged. The Auto Air Valve will also not open completely if it is not receiving sufficient signal air pressure.

5. There is an obstruction between the Choke Valve and the Metering Valve. Depressurize the Abrasive Blaster and disassemble the string of components between the Choke Valve and Metering Valve. Remove the obstruction and reassemble the components.

ABRASIVE BLASTER AIR BLAST STOPS BUT ABRASIVE KEEPS FLOWING WHEN CONTROL HANDLE IS RELEASED

Possible Causes:

1. The Urethane Seat (black) in the Metering Valve is damaged, defective or worn out.
2. The Urethane Sleeve (black) in the Metering Valve is damaged, defective, or worn out.
3. The Plunger (tungsten carbide) in the Metering Valve is damaged, defective, or worn out.
4. Foreign material is stuck between the Plunger and the Seat in the Metering Valve.
5. The Metering Valve Spring is damaged, defective, or worn out.

BLAST MACHINE ABRASIVE STOPS BUT AIR BLAST WILL NOT SHUT OFF WHEN CONTROL HANDLE IS RELEASED

Possible Causes:

1. Auto Air Valve Seat is damaged, defective, or worn out.
2. Auto Air Valve Disc is damaged, defective, or worn out.
3. "O"-ring on the Auto Air Valve Shaft is damaged, defective or worn out.
4. Auto Air Valve Spring is damaged, defective, or worn out.

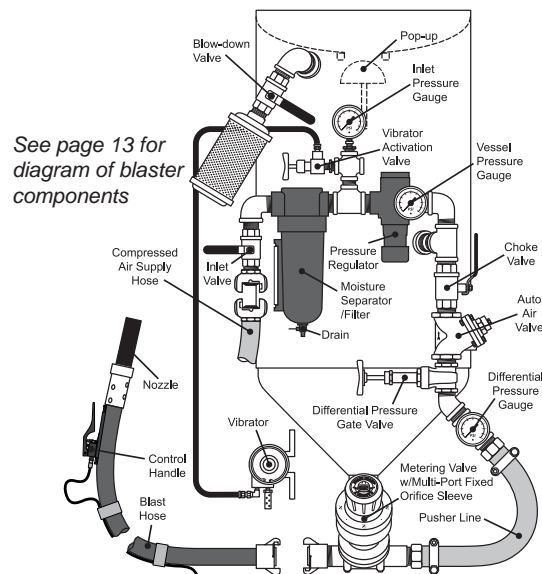



SODA STORM™ BLASTERS - USER'S MANUAL

WARRANTY

PIRATE BRAND® ABRASIVE BLAST POT EQUIPMENT 5 YEAR / 10 YEAR LIMITED WARRANTY

5 YEAR LIMITED ABRASIVE BLAST POT WARRANTY. Manufacturer warrants the complete abrasive blast pot it manufactures to be free of defects in material and workmanship for a period of five (5) years from the date of invoice.

10 YEAR LIMITED PRESSURE VESSEL WARRANTY. Manufacturer warrants the abrasive blast pot pressure vessel it manufactures to be free of defects in material and workmanship for a period of ten (10) years from the date of invoice.

LIMITATION OF WARRANTIES AND REMEDIES. THIS WARRANTY IS EXTENDED ONLY TO THE BUYER WHO PURCHASES THE ABRASIVE BLAST POT DIRECTLY FROM THE MANUFACTURER OR ITS AUTHORIZED DISTRIBUTORS AND IS NON-TRANSFERABLE. THE PURCHASER'S EXCLUSIVE REMEDY ARISING FROM ITS PURCHASE OR USE OF THE PRODUCT SHALL BE STRICTLY LIMITED TO THE REPAIR OR REPLACEMENT OF THE PRODUCTS, AT THE DISCRETION OF THE MANUFACTURER, AND ALL WARRANTY CLAIMS OR REQUESTS MUST BE MADE IN WRITING TO THE MANUFACTURER WITHIN TEN (10) DAYS AFTER FAILURE OF THE PRODUCT. ALL OBLIGATIONS OR LIABILITIES OF MANUFACTURER OR SELLER FOR DAMAGES ARISING OUT OF OR IN CONNECTION WITH THE PRODUCT AND USE OR PERFORMANCE OF THE PRODUCTS, EXCEPT AS EXPRESSLY PROVIDED HEREIN, ARE FULLY DISCLAIMED AND EXCLUDED, AND NO SELLER OR DISTRIBUTOR HAS ANY AUTHORITY TO MAKE ANY WARRANTY OR ASSUME ANY LIABILITY ON BEHALF OF THE MANUFACTURER IN CONNECTION WITH THE SALE OF THE PRODUCT EXCEPT AS STATED HEREIN.

AS A CONDITION OF THE PURCHASE, PURCHASER AGREES THAT MANUFACTURER AND SELLER SHALL NOT, UNDER ANY CIRCUMSTANCES, BE LIABLE FOR ANY COST OF FREIGHT, SHIPPING OR TRANSPORTATION, LABOR, SPECIAL CHARGES, NORMAL MAINTENANCE SERVICES, LOST OPERATING TIME, LOSS OF USE, LOST PROFITS, LOSS OF GOODWILL, CONSEQUENTIAL DAMAGES, PUNITIVE OR EXEMPLARY DAMAGES, OR OTHER DAMAGES OR LOSS. OTHER THAN AS DESCRIBED HEREIN, MANUFACTURER AND SELLER MAKE NO WARRANTY OF ANY KIND, EXPRESS OR IMPLIED, WITH RESPECT TO THE PRODUCTS, AND SPECIFICALLY DISCLAIM ANY WARRANTY OF MERCHANTABILITY, FITNESS FOR A PARTICULAR PURPOSE, OR OTHER WARRANTY. PURCHASER ASSUMES ALL RISK AND LIABILITY RESULTING FROM THE USE OF THE PRODUCTS. PURCHASER FURTHER AGREES AS A CONDITION OF THE SALE AND THE USE OF THE PRODUCT, THAT ANY DAMAGES OR RISK OF LOSS OTHER THAN AS DESCRIBED HEREIN ABOVE, SHALL BE THE EXCLUSIVE RESPONSIBILITY OF THE PURCHASER AND NOT THE MANUFACTURER OR SELLER. MANUFACTURER AND SELLER SHALL NOT BE LIABLE FOR ANY DAMAGES INCURRED BY ANY PERSON AS A RESULT OF MISUSE, IMPROPER INSTALLATION, IMPROPER APPLICATION, IMPROPER OPERATION OF THE PRODUCTS, NORMAL WEAR AND TEAR, ALTERATIONS OR MODIFICATIONS MADE TO THE PRODUCTS, OR ACCIDENT. THE USE OF REPLACEMENT PARTS NOT PROVIDED OR AUTHORIZED BY THE MANUFACTURER VOIDS ALL WARRANTIES.

A COMPLETELY FILLED OUT WARRANTY CARD MUST BE RETURNED TO THE MANUFACTURER WITHIN THIRTY (30) DAYS OF PURCHASE OF THE PRODUCT OR ALL WARRANTIES ARE VOID. PRODUCT MUST BE MAINTAINED IN ACCORDANCE TO THE MAINTENANCE SCHEDULE PROVIDED IN THE PRODUCT MANUAL, FAILURE TO MAINTAIN THE PRODUCT IN ACCORDANCE WITH THE MAINTENANCE SCHEDULE VOIDS ALL WARRANTIES. THIS WARRANTY DOES NOT COVER FACTORY INSTALLED OR CUSTOMER INSTALLED ACCESSORIES.

WARRANTY CLAIMS. Warranty claims must be submitted to the manufacturer within ten (10) days after failure of the product. Contact information for warranty claims:

Forecast Sales, Inc.
2719 Tobey Dr.
Indianapolis, IN 46219
317-829-0147

Effective July 8, 2015



☠️ PRESSURE VESSEL PARTS LISTS ☠️

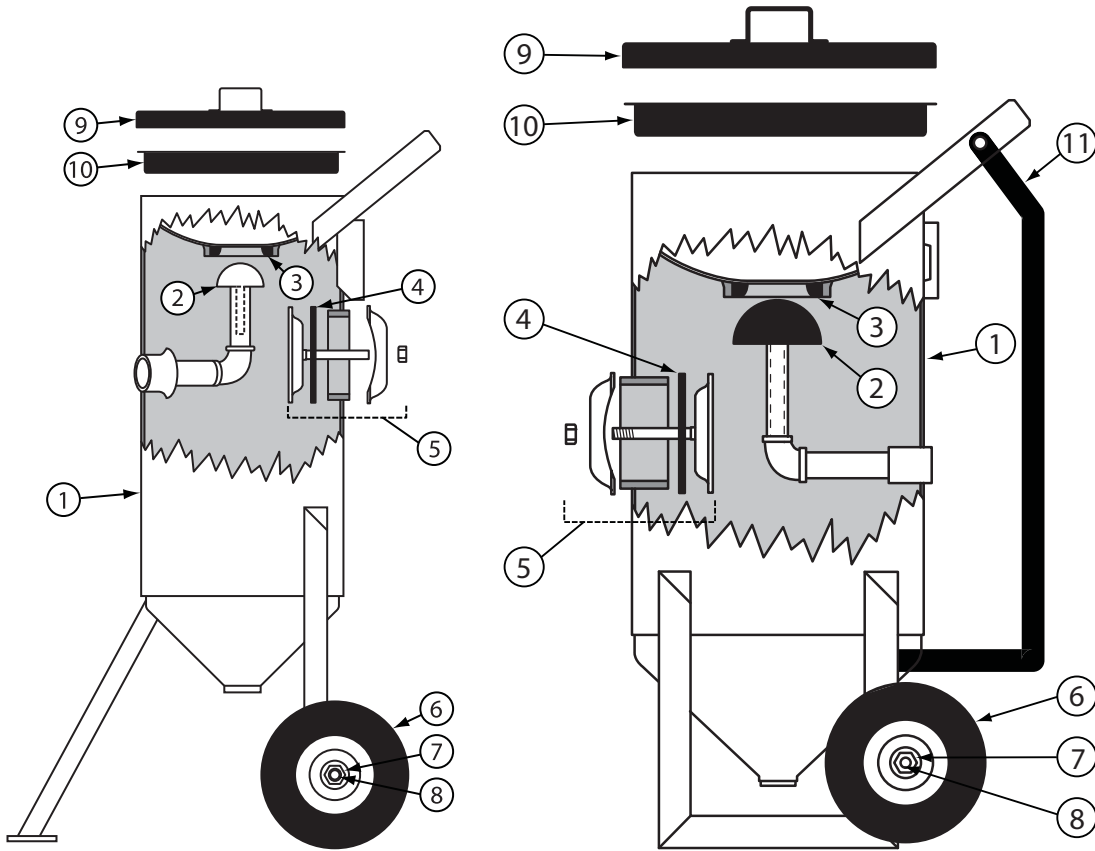

1.5 SODA STORM™		
1	888-1011-00102PB	VESSEL, PORTABLE, 1.5 CU. FT. (43 LITERS), 150 PSI (10.3 BAR), 90° CONE BOTTOM, 9" CLEARANCE, 12" DIA, INCLUDES HANDWAY ASSEMBLY, WHEELS, POP-UP & POP-UP GASKET
2	888-2100-000PB	POP-UP W/STEM URETHANE, SMALL
3	888-2100-001PB	POP-UP GASKET URETHANE, SMALL
4	888-7000-00006PB	GASKET, HANDWAY, 4" x 6"
5	888-7000-00011PB	HANDWAY CRAB ASSY 4" x 6"
6	888-7046-003PB	WHEEL & TIRE
7	888-7019-519PB	NUT, NYLOCK, 3/4" UNC
8	888-7040-003BP	AXLE, 3/4" x 22"
9	888-5010-010PB	LID, 12" DIA
10	888-5011-010PB	SCREEN, LOW PROFILE, 12" (1/4" MESH)

3.5 SODA STORM™		
1	888-1011-00303PB	VESSEL, PORTABLE, 3.5 CU. FT. (100 LITERS), 150 PSI (10.3 BAR), 90° CONE BOTTOM, 9" CLEARANCE, 18" DIA, INCLUDES HANDWAY ASSEMBLY, WHEELS, POP-UP & POP-UP GASKET
2	888-2100-010PB	POP-UP W/STEM URETHANE, LARGE
3	888-2100-011PB	POP-UP GASKET URETHANE, LARGE
4	888-7000-00106PB	GASKET, HANDWAY, 6" x 8"
5	888-7000-00111PB	HANDWAY CRAB ASSY 6" x 8"
6	888-7046-003PB	WHEEL & TIRE, 3 BAG POT
7	888-7019-519PB	NUT, NYLOCK, 3/4" UNC
8	888-7040-003PB	AXLE, 3/4" x 22", 1 BAG, 3 BAG & 1600 M
9	888-5010-030PB	LID, 18" DIA, W/HANDLE, POWDER COATED BLACK
10	888-5011-030PB	SCREEN, LOW PROFILE, 18" (1/4" MESH), POWDER COATED BLACK
11	888-7002-003PB	LOADING SKID / VALVE GUARD 3 BAG, POWDER COATED BLACK

6.5 SODA STORM™		
1	888-1011-00603PB	VESSEL, PORTABLE, 6.5 CU. FT. (185 LITERS), 150 PSI (10.3 BAR), 90° CONE BOTTOM, 9" CLEARANCE, 24" DIA, INCLUDES HANDWAY ASSEMBLY, WHEELS, POP-UP & POP-UP GASKET
2	888-2100-010PB	POP-UP W/STEM URETHANE, LARGE
3	888-2100-011PB	POP-UP GASKET URETHANE, LARGE
4	888-7000-00106PB	GASKET, HANDWAY, 6" x 8"
5	888-7000-00111PB	HANDWAY CRAB ASSY 6" x 8"
6	888-7046-006PB	WHEEL & TIRE, 6 - 10 BAG POT
7	888-7019-527PB	NUT, NYLOCK, 1" UNC
8	888-7040-006PB	AXLE 1" x 33", 6 - 10 BAG POT
9	888-5010-060PB	LID, 24" DIA, W/HANDLE, POWDER COATED BLACK
10	888-5011-060PB	SCREEN, LOW PROFILE, 24" (1/4" MESH), POWDER COATED BLACK
11	888-7002-006PB	LOADING SKID / VALVE GUARD 6 BAG, POWDER COATED BLACK



PIPE STRING PARTS LISTS

1.5 CU FT SODA STORM

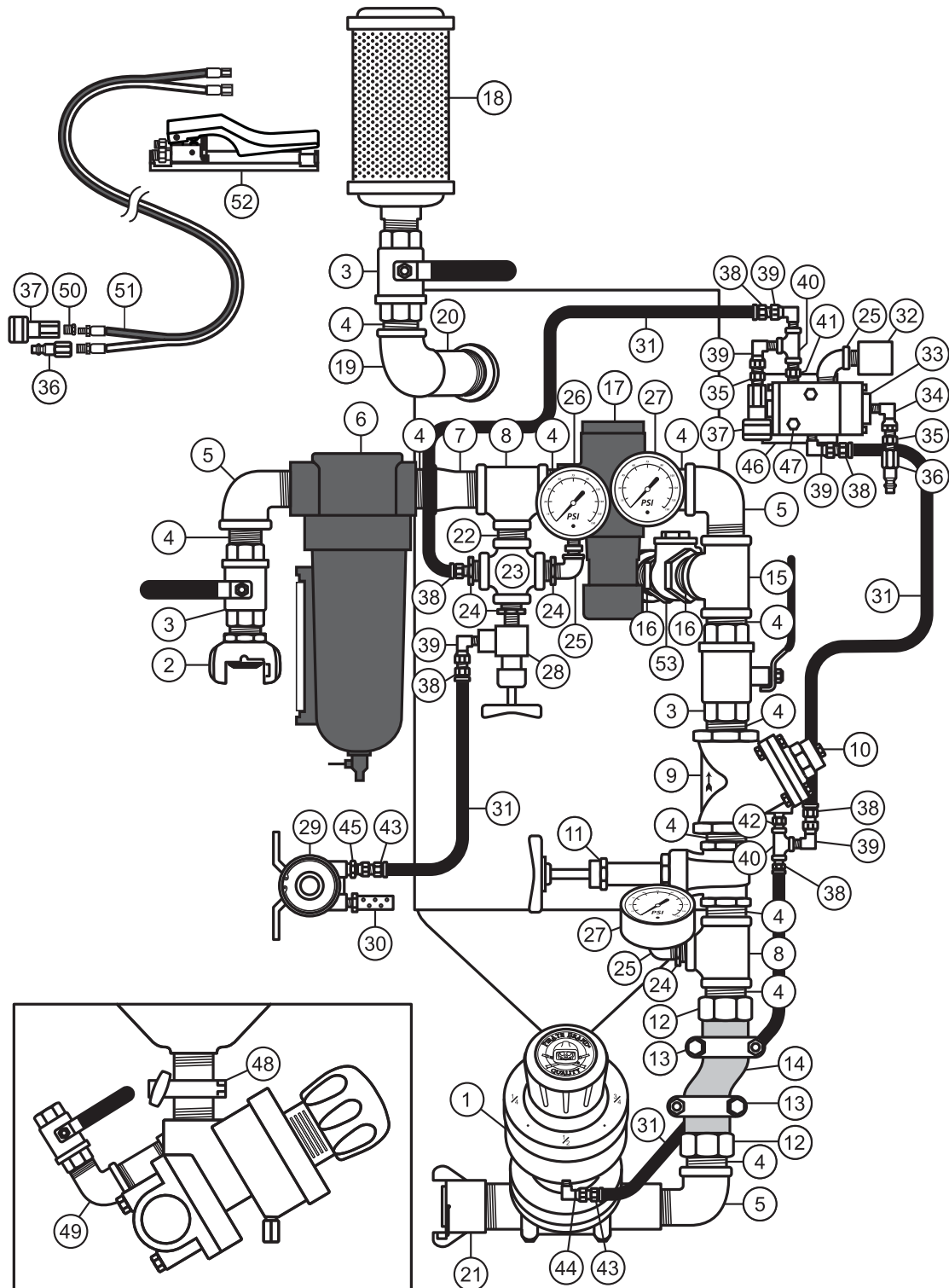

Some items rotated for visibility.



☠ PIPE STRING PARTS LISTS ☠

1.5 CU FT SODA STORM

1*	888-2148-006PB	APV II, 1" W/SOLID TUNGSTEN CARBIDE SLEEVE	30	109-063	DIFFUSER 1/8" SINTERED
2	UM-100	AIR HOSE COUPLINGS, 2 LUG, 1" MALE NPT	31	888-4101-002PB	HOSE, AIR, INSTA-GRIP, BLACK, NOMINAL 1/4" ID, 300 PSI, PER FOOT
3	VB100	BALL VALVE, FULL PORT, 1" NPT	32	888-2013-402PB	DUST ELIMINATOR, 1/4" MNPT
4	888-3029-10699PB	NIPPLE, TBE, GALV, 1" x CLOSED	33	888-2229-000PB	VALVE, CONTROL, PNEUMATIC (NORMALLY CLOSED)
5	888-3006-106PB	ELBOW, STREET, 90°, GALV, 1"		888-2229-00099PB	VALVE, CONTROL, PNEUMATIC, REPAIR KIT, HEAVY DUTY
6	888-2302-30650PB	AIR FILTER, 1" 50 MICRON MB/SG/MD	34	888-4203-50002PB	SWIVEL 90°, 1/8" MNPT x 1/4" F
	505-161	REPAIR KIT, AIR FILTER, 3/4", 1", 1-1/4" & 1-1/2"	35	888-3031-30202PB	HEX NIPPLE 1/4" NPT x 1/4" W/BALL ST
	888-2302-20798PB	FILTER ELEMENT 3/4", 1", 1-1/4" & 1-1/2", 50 MICRON	36	888-4224-30002PB	PLUG, 1/4"
7	888-3008-106PB	ELBOW, STREET, 45°, GALV, 1"	37	888-4224-30102PB	BRASS SOCKET, 1/4"
8	888-3011-10604PB	TEE, GALV, 1" x 1" x 1/2"	38	888-4200-30202PB	HOSE, PUSH-ON INSERT 1/4" x 1/4" NPT
9*	888-2123-106PB	VALVE, AUTO AIR, 1", (NORMALLY CLOSED)	39	888-4203-50202PB	SWIVEL 90°, 1/4" MNPT x 1/4" F
10	888-2014-300PB	VENT, 1/8"	40	888-3011-102PB	TEE, GALV, 1/4"
11	888-2423-906PB	GATE VALVE, 1" BRZ 125	41	888-3031-31202PB	NIPPLE, HEX 1/4" MNPT x 1/4" MNPT
12	888-4205-106PB	HOSE, INSERT SWIVEL, 1", INCLUDES GASKET	42	888-3031-31200PB	NIPPLE, HEX 1/4" MNPT x 1/8" MNPT
	888-4205-10699PB	HOSE, SWIVEL GASKET, 1"	43	888-4200-30200PB	HOSE, PUSH-ON INSERT 1/4" x 1/8" NPT
13	888-4235-006PB	HOSE, CLAMP, DOUBLE BOLT, 1"	44	888-4203-50000PB	SWIVEL 90°, 1/8" MNPT x 1/8" F
14	112-0100	HOSE, AIR, RED, NOMINAL 1" ID x 1-1/2" OD, WP 300 PSI, PER FOOT	45	888-4201-50000PB	STRAIGHT SWIVEL, 1/8" MNPT x 1/8" F
15	888-3011-106PB	TEE, GALV, 1"	46	888-7033-002PB	BRACKET, CONTROL VALVE
16	888-3028-10699PB	NIPPLE, TBE, SCHEDULE 80, GALV, 1" x CLOSED		110120300	BOLT, 1/4" x 1/2" (2 REQUIRED)
17	888-2003-006PB	REGULATOR 1" NON-RELIEVING (440 SCFM)	47	552-752	LOCK WASHER, 1/4" (2 REQUIRED)
18	888-2011-006PB	MUFFLER, BLOWDOWN, 1" MNPT		110120306	BOLT, 1/4" x 1-1/2" (2 REQUIRED)
19	888-3010-10706PB	ELBOW, REDUCING, GALV, 1-1/4" x 1"	48	552-752	LOCK WASHER, 1/4" (2 REQUIRED)
20	888-3029-10715PB	NIPPLE, TBE, GALV, 1-1/4" x 5"		999-8710-92301PB	SANITARY CLAMP
21	SB-2-IR	THD QUICK COUPLING, IRON, 1-1/2"	49	999-8710-98502PB	CLAMP FITTING, 1-1/4" MNPT (2 REQUIRED)
22	888-3029-10499PB	NIPPLE, TBE, GALV, 1/2" x CLOSED		999-8710-98503PB	SANITARY CLAMP, O-RING
23	888-3016-10404PB	CROSS, GALV, 1/2"	50	999-8403-00054PB	APV II CLEANOUT BALL VALVE ASSY
24	888-3026-10402PB	BUSHING, GALV, 1/2" x 1/4"	51	888-3026-50200PB	BUSHING, PLATED 1/4" x 1/8" NPT
25	888-3006-102PB	ELBOW, STREET, 90°, GALV, 1/4"	52**	200-055	HOSE, TWINLINE CONTROL, ASSEMBLY, YEL/YEL W/BLACK STRIP, NOMINAL 3/16" ID x 55'
26	888-2010-00901PB	GAUGE, PRESSURE, 0-160 PSI			888-2263-001PB
27	888-2010-010PB	GAUGE, PRESSURE, 0-160 PSI BACK MNT		888-2263-000PB	HANDLE, CONTROL, PNEUMATIC
28	888-2430-804PB	ANGLE VALVE, 1/4"	53	VC-100	CHECK VALVE, SWING 1"
29	888-2020-013PB	#13 VIBRATOR, 1/8" FNPT			

* See "Valve Parts Lists" Section for detailed parts list.

** See "Control Handle Parts Lists" Section for detailed parts list.



PIPE STRING PARTS LISTS

3.5 CU FT SODA STORM

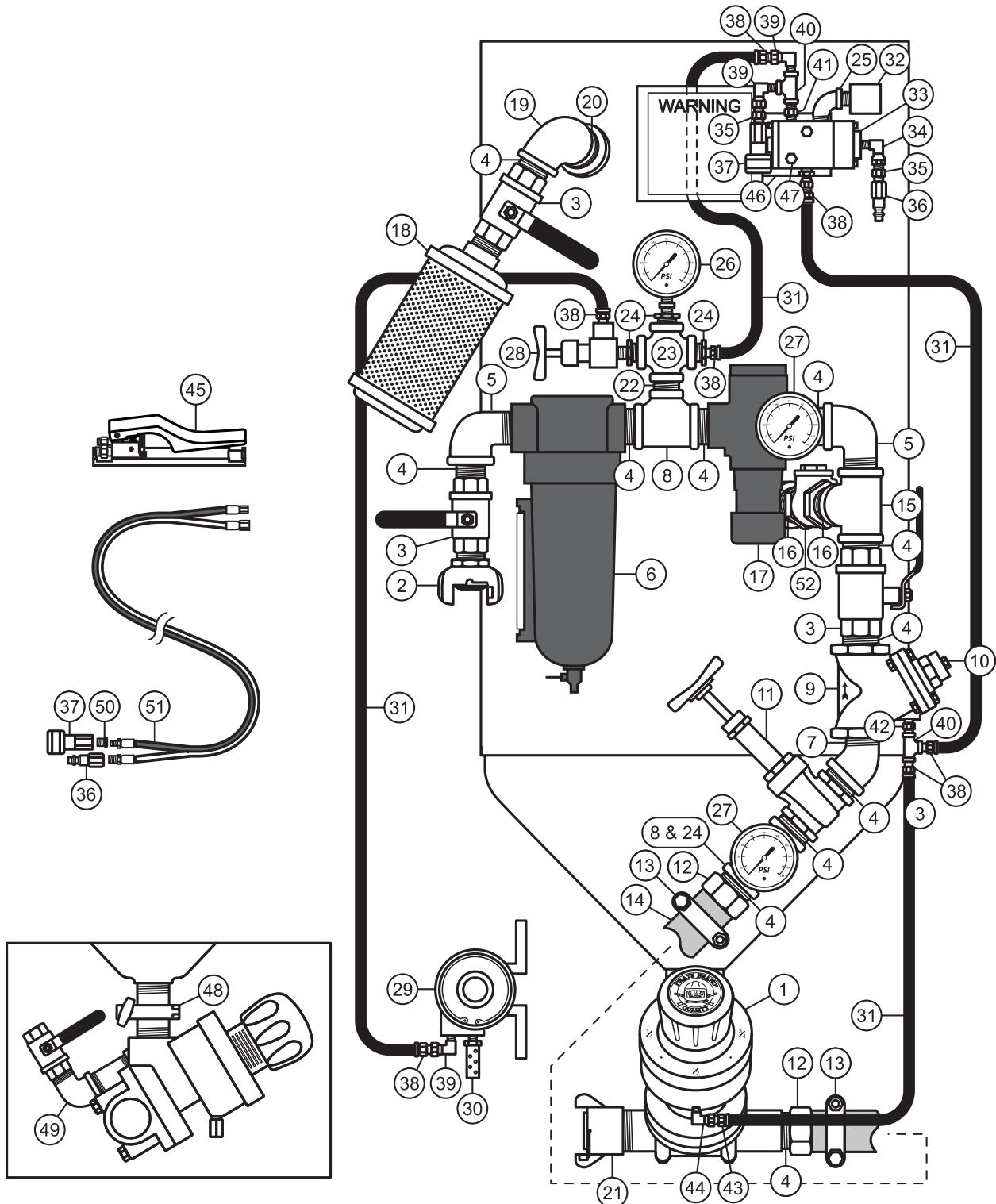

Some items rotated for visibility.



☠ PIPE STRING PARTS LISTS ☠

3.5 CU FT SODA STORM

1*	888-2148-006PB	APV II, 1" W/SOLID TUNGSTEN CARBIDE SLEEVE	29	888-2020-025PB	VIBRATOR, # 25, 1/4" FNPT
2	UM-100	AIR HOSE COUPLINGS, 2 LUG, 1" MALE NPT	30	888-2011-002PB	MUFFLER, 1/4" MNPT (EXHAUST)
3	VB100	BALL VALVE, FULL PORT, 1" NPT	31	888-4101-002PB	HOSE, AIR, INSTA-GRIP, BLACK, NOMINAL 1/4" ID, 300 PSI, PER FOOT
4	888-3029-10699PB	NIPPLE, TBE, GALV, 1" x CLOSED	32	888-2013-402PB	DUST ELIMINTOR, 1/4" MNPT
5	888-3006-106PB	ELBOW, STREET, 90°, GALV, 1"	33	888-2229-000PB	VALVE, CONTROL, PNEUMATIC (NORMALLY CLOSED)
6	888-2302-30650PB	AIR FILTER, 1" 50 MICRON MB/SG/MD		888-2229-00099PB	VALVE, CONTROL, PNEUMATIC, REPAIR KIT, HEAVY DUTY
	505-161	REPAIR KIT, AIR FILTER, 3/4", 1", 1-1/4" & 1-1/2"	34	888-4203-50002PB	SWIVEL 90°, 1/8" MNPT x 1/4" F
	888-2302-20798PB	FILTER ELEMENT 3/4", 1", 1-1/4" & 1-1/2", 50 MICRON	35	888-3031-30202PB	HEX NIPPLE 1/4" NPT x 1/4" W/BALL ST
7	888-3008-106PB	ELBOW, STREET, 45°, GALV, 1"	36	888-4224-30002PB	PLUG, 1/4"
8	888-3011-10604PB	TEE, GALV, 1" x 1" x 1/2"	37	888-4224-30102PB	BRASS SOCKET, 1/4"
9*	888-2123-106PB	VALVE, AUTO AIR, 1", (NORMALLY CLOSED)	38	888-4200-30202PB	HOSE, PUSH-ON INSERT 1/4" x 1/4" NPT
10	888-2014-300PB	VENT, 1/8"	39	888-4203-50202PB	SWIVEL 90°, 1/4"MNPT x 1/4"F
11	888-2423-906PB	GATE VALVE, 1" BRZ	40	888-3011-102PB	TEE, GALV, 1/4"
12	888-4205-106PB	HOSE, INSERT SWIVEL, 1", INCLUDES GASKET	41	888-3031-31202PB	NIPPLE, HEX 1/4"MNPT x 1/4" MNPT
	888-4205-10699PB	HOSE, SWIVEL GASKET, 1"	42	888-3031-31200PB	NIPPLE, HEX 1/4"MNPT x 1/8" MNPT
13	888-4235-006PB	HOSE, CLAMP, DOUBLE BOLT, 1"	43	888-4200-30200PB	HOSE, PUSH-ON INSERT 1/4" x 1/8" NPT
14	112-0100	HOSE, AIR, RED, NOMINAL 1" ID x 1-1/2" OD, WP 300 PSI, PER FOOT	44	888-4203-50000PB	SWIVEL 90°, 1/8"MNPT x 1/8"F
15	888-3011-10607PB	TEE, GALV, 1" x 1" x 1-1/4"	45**	888-2263-001PB	HANDLE, CONTROL, PNEUMATIC #2
16	888-3028-10799PB	NIPPLE, TBE, SCHEDULE 80, GALV, 1-1/4" x CLOSED		888-2263-000PB	HANDLE, CONTROL, PNEUMATIC
17	888-2003-006PB	REGULATOR 1" NON-RELIEVING (440 SCFM)		888-7033-002PB	BRACKET, CONTROL VALVE
18	888-2011-006PB	MUFFLER, BLOWDOWN, 1" MNPT	46	110120300	BOLT, 1/4" x 1/2" (2 REQUIRED)
19	888-3010-10706PB	ELBOW, REDUCING, GALV, 1-1/4" x 1"		552-752	LOCK WASHER, 1/4" (2 REQUIRED)
20	888-3029-10799PB	NIPPLE, TBE, GALV, 1-1/4" x CLOSED	47	110120306	BOLT, 1/4" x 1-1/2" (2 REQUIRED)
21	SB-2-IR	THD QUICK COUPLING, IRON, 1-1/2"		552-752	LOCK WASHER, 1/4" (2 REQUIRED)
22	888-3029-10499PB	NIPPLE, TBE, GALV, 1/2" x CLOSED	48	999-8710-92301PB	SANITARY CLAMP
23	888-3016-10404PB	CROSS, GALV, 1/2"		999-8710-98502PB	CLAMP FITTING, 1-1/4" MNPT (2 REQUIRED)
24	888-3026-10402PB	BUSHING, GALV, 1/2" x 1/4"		999-8710-98503PB	SANITARY CLAMP, O-RING
25	888-3006-102PB	ELBOW, STREET, 90°, GALV, 1/4"	49	999-8403-00054PB	APV II CLEANOUT BALL VALVE ASSY
26	888-2010-00901PB	GAUGE, PRESSURE, 0-160 PSI	50	888-3026-50200PB	BUSHING, PLATED 1/4" x 1/8"NPT
27	888-2010-010PB	GAUGE, PRESSURE, 0-160 PSI BACK MNT	51	200-055	HOSE, TWINLINE CONTROL, ASSEMBLY, YEL/YEL W/BLACK STRIP, NOMINAL 3/16" ID x 55'
28	888-2430-804PB	ANGLE VALVE, 1/4"	52	VC-125	CHECK VALVE, SWING 1-1/4"

* See "Valve Parts Lists" Section for detailed parts list.

** See "Control Handle Parts Lists" Section for detailed parts list.



PIPE STRING PARTS LISTS

6.5 CU FT SODA STORM

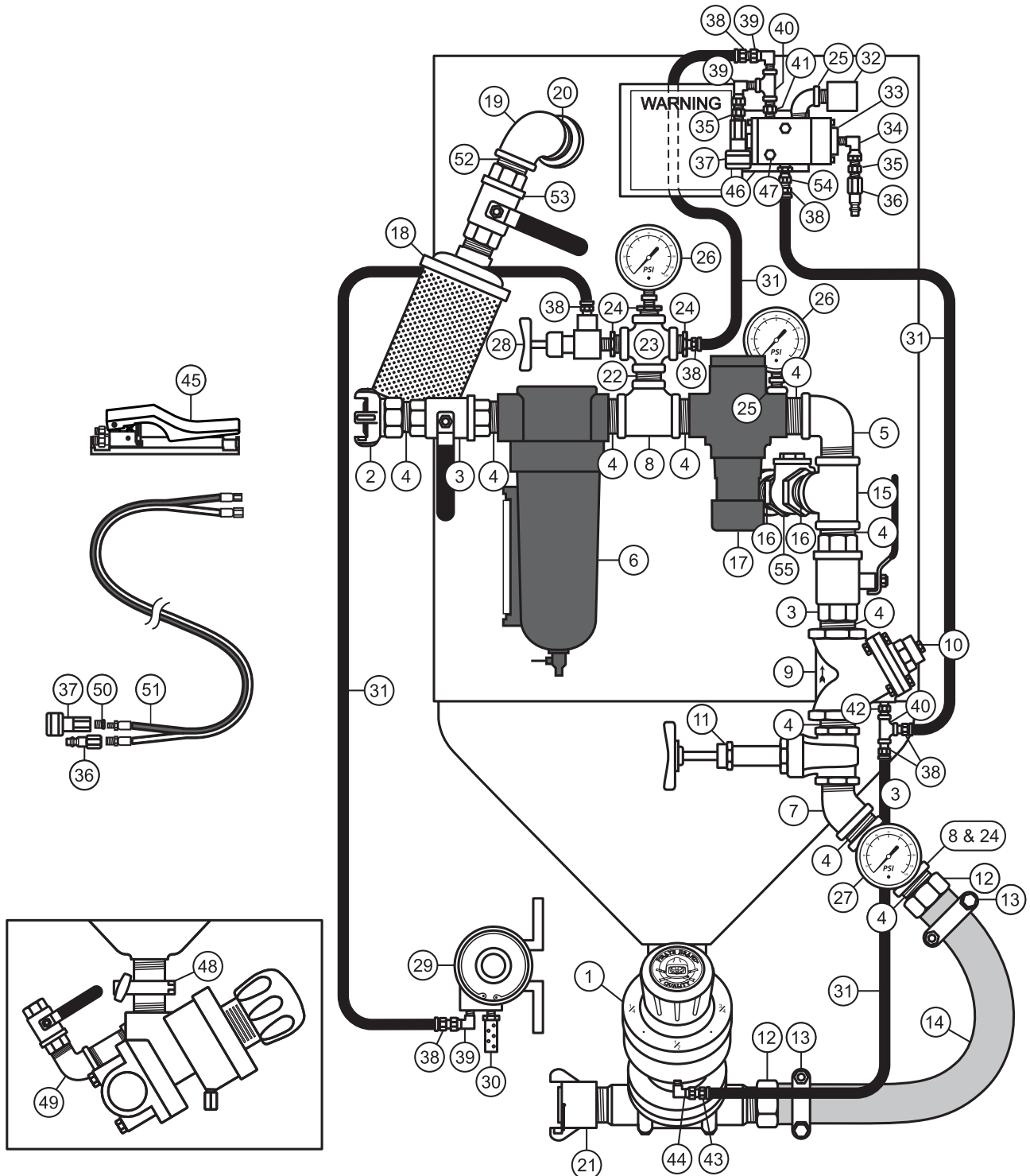

Some items rotated for visibility.



☠ PIPE STRING PARTS LISTS ☠

6.5 CU FT SODA STORM

1*	888-2148-007PB	APV II, 1-1/4" W/SOLID TUNGSTEN CARBIDE SLEEVE	30	888-2011-002PB	MUFFLER, 1/4" MNPT (EXHAUST)
2	UF-125	AIR HOSE COUPLINGS, 4 LUG, 1-1/4" FEMALE NPT	31	888-4101-002PB	HOSE, AIR, INSTA-GRIP, BLACK, NOMINAL 1/4" ID, 300 PSI, PER FOOT
3	VB125	BALL VALVE, FULL PORT, 1-1/4" NPT	32	888-2013-402PB	DUST ELIMINATOR, 1/4" MNPT
4	888-3029-10799PB	NIPPLE, TBE, GALV, 1-1/4" x CLOSED	33	888-2229-000PB	VALVE, CONTROL, PNEUMATIC (NORMALLY CLOSED)
5	888-3006-107PB	ELBOW, STREET, 90°, GALV, 1-1/4"		888-2229-00099PB	VALVE, CONTROL, PNEUMATIC, REPAIR KIT, HEAVY DUTY
6	888-2302-20750PB	AIR FILTER, 1-1/4" 50 MICRON MB/SG/MD	34	888-4203-50002PB	SWIVEL 90°, 1/8" MNPT x 1/4" F
	505-161	REPAIR KIT, AIR FILTER, 3/4", 1", 1-1/4" & 1-1/2"	35	888-3031-30202PB	HEX NIPPLE 1/4" NPT x 1/4" W/BALL ST
	888-2302-20798PB	FILTER ELEMENT 3/4", 1", 1-1/4" & 1-1/2", 50 MICRON	36	888-4224-30002PB	PLUG, 1/4"
7	888-3008-107PB	ELBOW, STREET, 45°, GALV, 1-1/4"	37	888-4224-30102PB	BRASS SOCKET, 1/4"
8	888-3011-10704PB	TEE, GALV, 1-1/4" x 1-1/4" x 1/2"	38	888-4200-30202PB	HOSE, PUSH-ON INSERT 1/4" x 1/4" NPT
9*	888-2123-107PB	VALVE, AUTO AIR, 1-1/4", (NORMALLY CLOSED)	39	888-4203-50202PB	SWIVEL 90°, 1/4" MNPT x 1/4" F
10	888-2014-300PB	VENT, 1/8"	40	888-3011-102PB	TEE, GALV, 1/4"
11	888-2423-907PB	GATE VALVE, 1-1/4" BRZ	41	888-3031-31202PB	NIPPLE, HEX 1/4" MNPT x 1/4" MNPT
12	888-4205-107PB	HOSE, INSERT SWIVEL, 1-1/4", INCLUDES GASKET	42	888-3031-31200PB	NIPPLE, HEX 1/4" MNPT x 1/8" MNPT
	888-4205-10799PB	HOSE, SWIVEL GASKET, 1-1/4"	43	888-4200-30200PB	HOSE, PUSH-ON INSERT 1/4" x 1/8" NPT
13	888-4235-007PB	HOSE, CLAMP, DOUBLE BOLT, 1-1/4"	44	888-4203-50000PB	SWIVEL 90°, 1/8" MNPT x 1/8" F
14	112-0114	HOSE, AIR, RED, NOMINAL 1-1/4" ID x 1-51/64" OD, WP 250 PSI, PER FOOT	45**	888-2263-001PB	HANDLE, CONTROL, PNEUMATIC #2
15	888-3011-107PB	TEE, GALV, 1-1/4"		888-2263-000PB	HANDLE, CONTROL, PNEUMATIC
16	888-3028-10799PB	NIPPLE, TBE, SCHEDULE 80, GALV, 1-1/4" x CLOSED	46	888-7033-002PB	BRACKET, CONTROL VALVE
17	888-2003-007PB	REGULATOR 1-1/4" NON-RELIEVING (440 SCFM)		110120300	BOLT, 1/4" x 1/2" (2 REQUIRED)
18	888-2011-006PB	MUFFLER, BLOWDOWN, 1" MNPT	552-752	LOCK WASHER, 1/4" (2 REQUIRED)	
19	888-3010-10706PB	ELBOW, REDUCING, GALV, 1-1/4" x 1"	110120306	BOLT, 1/4" x 1-1/2" (2 REQUIRED)	
20	888-3029-10799PB	NIPPLE, TBE, GALV, 1-1/4" x CLOSED	552-752	LOCK WASHER, 1/4" (2 REQUIRED)	
21	SB-1S-IR	THRD CPLG, STD NPS, IRON, 1-1/4"	48	999-8710-92301PB	SANITARY CLAMP
22	888-3029-10499PB	NIPPLE, TBE, GALV, 1/2" x CLOSED		999-8710-98502PB	CLAMP FITTING, 1-1/4" MNPT (2 REQUIRED)
23	888-3016-10404PB	CROSS, GALV, 1/2"		999-8710-98503PB	SANITARY CLAMP, O-RING
24	888-3026-10402PB	BUSHING, GALV, 1/2" x 1/4"	49	999-8403-00054PB	APV II CLEANOUT BALL VALVE ASSY
25	888-3006-102PB	ELBOW, STREET, 90°, GALV, 1/4"	50	888-3026-50200PB	BUSHING, PLATED 1/4" x 1/8" NPT
26	888-2010-00901PB	GAUGE, PRESSURE, 0-160 PSI	51	200-055	HOSE, TWINLINE CONTROL, ASSEMBLY, YEL/YEL W/BLACK STRIP, NOMINAL 3/16" ID x 55'
27	888-2010-010PB	GAUGE, PRESSURE, 0-160 PSI BACK MNT		52	888-3029-10699PB
28	888-2430-804PB	ANGLE VALVE, 1/4"	53	VB100	BALL VALVE, FULL PORT, 1" NPT
29	888-2020-025PB	VIBRATOR, # 25, 1/4" FNPT	54	888-4201-50202PB	STRAIGHT SWIVEL, 1/4" MNPT x 1/4" F
			55	VC-125	CHECK VALVE, SWING 1-1/4"

* See "Valve Parts Lists" Section for detailed parts list.

** See "Control Handle Parts Lists" Section for detailed parts list.



PIPE STRING PARTS LISTS

ABRASIVE CUT-OFF CONTROLS

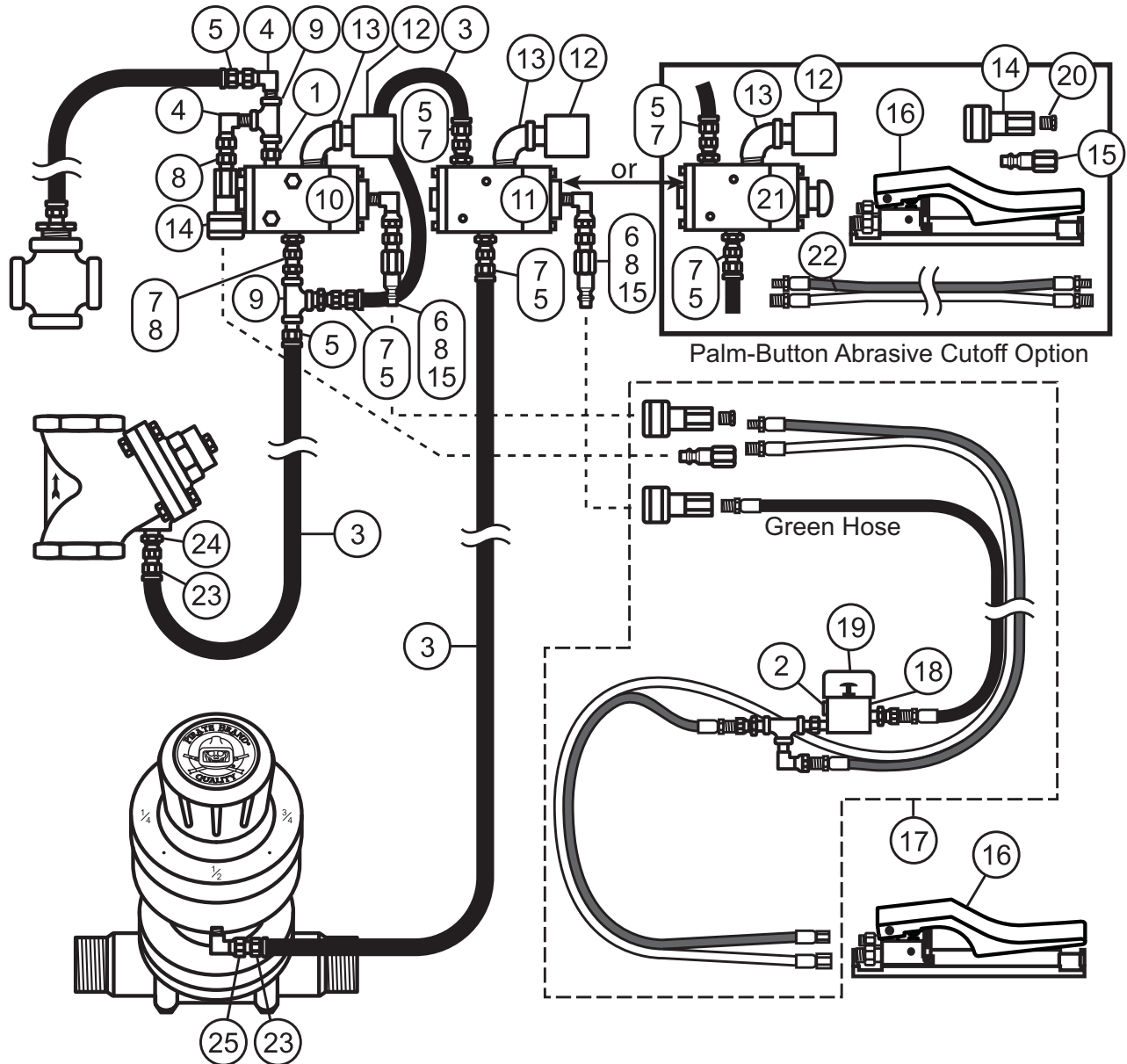



☠ PIPE STRING PARTS LISTS ☠

ABRASIVE CUT-OFF CONTROLS

1	888-3031-31202PB	NIPPLE, HEX 1/4"MNPT x 1/4" MNPT
2	888-2014-300PB	VENT, 1/8"
3	888-4101-002PB	HOSE, AIR, INSTA-GRIP, BLACK, NOMINAL 1/4" ID, 300 PSI, PER FOOT
4	888-4203-50202PB	SWIVEL 90°, 1/4"MNPT x 1/4"F
5	888-4200-30202PB	HOSE, PUSH-ON INSERT 1/4" x 1/4" NPT
6	888-4203-50002PB	SWIVEL 90°, 1/8" MNPT x 1/4" F
7	888-4201-50202PB	STRAIGHT SWIVEL, 1/4"MNPT x 1/4"F
8	888-3031-30202PB	HEX NIPPLE 1/4" NPT x 1/4" W/BALL ST
9	888-3011-102PB	TEE, GALV, 1/4"
10	888-2229-000PB	VALVE, CONTROL, PNEUMATIC
	888-2229-00099PB	VALVE, CONTROL, PNEUMATIC, REPAIR KIT, HEAVY DUTY
11	888-2229-010PB	VALVE, CONTROL, PNEUMATIC (NORMALLY OPEN)
12	888-2013-402PB	DUST ELIMINATOR, 1/4" MNPT
13	888-3006-102PB	ELBOW, STREET, 90°, GALV, 1/4"
14	888-4224-30102PB	BRASS SOCKET, 1/4"
15	888-4224-30002PB	PLUG, 1/4"
16**	888-2263-001PB	HANDLE, CONTROL, PNEUMATIC #2
	888-2263-000PB	HANDLE, CONTROL, PNEUMATIC
17	888-4100-50102PB	HOSE, TWINLINE ASSY 55' ACO W/ABRASIVE CUTOFF SWITCH
18	888-2025-010PB	VALVE, ABRASIVE CUTOFF (PNEU)
19	888-2025-10001PB	TOGGLE SWITCH GUARD
20	888-3026-50200PB	BUSHING, PLATED 1/4" x 1/8"NPT
21	888-2229-301PB	VALVE, CONTROL, KNOB OPERATED 3W2P
	888-2229-30199PB	VALVE, CONTROL, KNOB OPERATED 3W2P, REPAIR KIT, HEAVY DUTY
22	200-055	HOSE, TWINLINE CONTROL, ASSEMBLY, YEL/YEL W/BLACK STRIP, NOMINAL 3/16" ID x 55'
23	888-4200-30200PB	HOSE, PUSH-ON INSERT 1/4" x 1/8" NPT
24	888-4201-50000PB	STRAIGHT SWIVEL, 1/8" MNPT X 1/8" F
25	888-4203-50000PB	SWIVEL 90°, 1/8"MNPT X 1/8"F

** See "**Control Handle Parts Lists**" Section for detailed parts list.



SODA STORM™ BLASTERS - USER'S MANUAL

☠ CONTROL HANDLE PARTS LISTS ☠

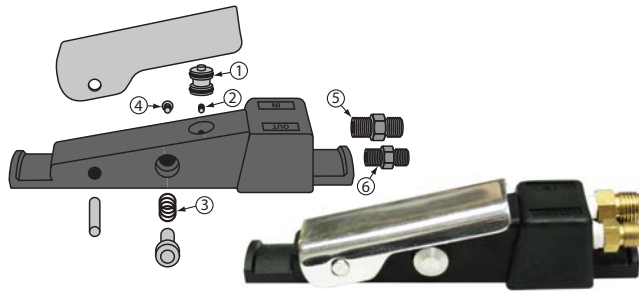

PNEUMATIC REMOTE CONTROL HANDLE (NOT FOR USE WITH STEEL ABRASIVES)	
	888-2263-000PB HANDLE, CONTROL, PNEUMATIC
	888-2263-00099PB HANDLE, CONTROL, PNEUMATIC, REPAIR KIT, INCLUDES # 1, 2, 3 & 4
5	888-3031-30202PB HEX NIPPLE 1/4" NPT x 1/4" W/BALL ST
6	888-3031-30000PB HEX NIPPLE 1/8" NPT x 1/8" W/BALL ST

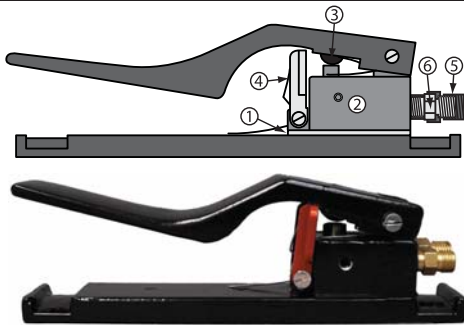

PNEUMATIC REMOTE CONTROL HANDLE #2	
	888-2263-001PB HANDLE, CONTROL, PNEUMATIC #2
	888-2263-00199PB HANDLE, CONTROL, PNEUMATIC #2, REPAIR KIT, INCLUDES #1, 2 & 3
4	888-2263-00108PB HANDLE, CONTROL, PNEUMATIC #2, SAFETY FLAP
5	888-3031-30202PB HEX NIPPLE 1/4" NPT x 1/4" W/BALL ST
6	888-3031-30000PB HEX NIPPLE 1/8" NPT x 1/8" W/BALL ST



PNEUMATIC REMOTE CONTROL HANDLE #3 (NOT FOR USE WITH STEEL ABRASIVES)	
	888-2263-002PB HANDLE, CONTROL, PNEUMATIC #3
	888-2263-00299PB HANDLE, CONTROL, PNEUMATIC #3, REPAIR KIT

☠ VALVE PARTS LISTS ☠

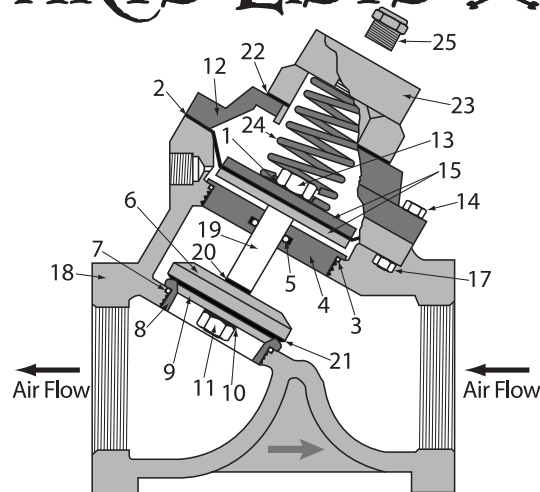

1" Auto Air Valve	
	888-2123-106PB VALVE, AUTO AIR, 1", (NORMALLY CLOSED)
	888-2123-00699PB VALVE, AUTO AIR, 1/2", 3/4" & 1", REPAIR KIT INCLUDES # 1, 2, 3, 5, 7, 11, 13, 20 & 21
24	888-2123-10624PBPB VALVE, AUTO AIR, 1/2", 3/4" & 1", SPRING
25	888-2014-300PB VENT, 1/8"

1-1/4" Auto Air Valve	
	888-2123-107PB VALVE, AUTO AIR, 1-1/4", (NORMALLY CLOSED)
	888-2123-00799PB VALVE, AUTO AIR, 1-1/4" & 1-1/2", REPAIR KIT INCLUDES # 1, 2, 3, 5, 7, 11, 13, 20 & 21
24	888-2123-00724PBPB VALVE, AUTO AIR, 1-1/4" & 1-1/2", SPRING
25	888-2014-300PB VENT, 1/8"



☠ VALVE PARTS LISTS ☠

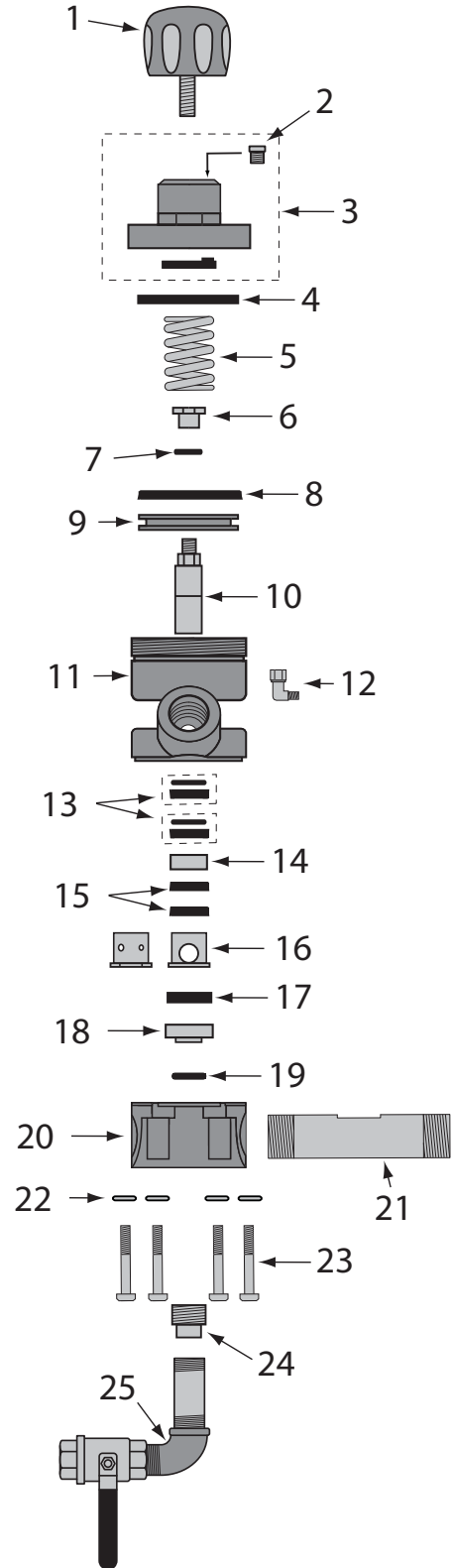

APVII™ (Automatic Plunger Valve II)		
	888-2148-006PB	APV II, 1" W/SOLID TUNGSTEN CARBIDE SLEEVE
	888-2148-007PB	APV II, 1-1/4" W/SOLID TUNGSTEN CARBIDE SLEEVE
	888-2148-008PB	APV II, 1-1/2" W/SOLID TUNGSTEN CARBIDE SLEEVE
	888-2148-00099PB	APV II, REPAIR KIT W/SOLID TUNGSTEN CARBIDE SLEEVE, INCLUDES (1) # 8 & 10, (2) # 13, (2) # 15, (1) #16, 17, 18 & 19
	888-2148-00098PB	APV II, SEAL KIT, SEALS ONLY, W/URETHANE SEAT, INCLUDES (1) # 8, (2) # 13 & 15, (1) # 17 & 19
1	888-2148-00001PB	APV II, KNOB (BLACK PIRATE BRAND)
2	888-2014-300PB	VENT, 1/8"
3	888-2148-00002PB	APV & APV II, CAP ASSEMBLY
4	888-2149-00019PB	APV & APV II, BUMP RING
5	888-2149-00003PB	APV & APV II, SPRING
6	888-2148-00015PB	APV II, PLUNGER STOP (STAINLESS)
7	888-2148-00016PB	APV II, NYLON WASHER
8	888-2148-00004PB	APV & APV II, PISTON SEAL (GREEN URETHANE)
9	888-2148-00005PB	APV II, PISTON
10	888-2148-00007PB	APV II, PLUNGER (STAINLESS/SOLID TUNGSTEN CARBIDE)
11	888-2148-00009PB	APV II, CYLINDER, W/1" NPT CLEANOUT
12	888-4203-50000PB	SWIVEL 90°, 1/8" MNPT X 1/8" F
13	888-2148-00006PB	APV & APV II, PLUNGER SEAL W/ "O"-RING (CLEAR URETHANE)
14	888-2148-00017PB	APV II, PLUNGER BUSHING (STAINLESS)
15	888-2148-30006PB	APV II, PLUNGER SEAL W/O "O"-RING (CLEAR URETHANE)
16	888-2148-00013PB	APV & APV II, SOLID TUNGSTEN CARBIDE SLEEVE
	888-2149-32020PB	APV & APV II, MULTI PORTED SLEEVE STAINLESS STEEL
17	888-2149-00010PB	APV & APV II, URETHANE SEAT
18	888-2148-00014PB	APV II, INSERT (STAINLESS)
19	888-2149-00018PB	APV & APV II, O-RING
20	888-2148-30011PB	APV II, BASE W/CLEANOUT
	888-2149-00615PB	APV & APV II, PIPE NIPPLE 1" FEMALE x 1-1/2" MALE
21	888-2149-00715PB	APV & APV II, PIPE NIPPLE 1-1/4" MALE x 1-1/4" MALE
	888-2149-00815PB	APV & APV II, PIPE NIPPLE 1-1/2" MALE x 1-1/2" MALE
22	888-7027-50302PB	APV & APV II, FLAT WASHER 3/8" SAE (10 PACK)
23	888-7010-50755PB	APV & APV II, BOLT, 4 PACK
24	888-3014-206PB	APV II, PLUG, PIPE STAINLESS 1"
25	999-8403-00054PB	APV II CLEANOUT BALL VALVE ASSY



SODA STORM™ BLASTERS - USER'S MANUAL

BLASTING SET-UP



BLAST HOSE	
Nozzles Not Included	
10-100BLK-050-3AL	1" BLAST HOSE ASSEMBLY, 50', BLACK, INCLUDES ALUMINUM NOZZLE HOLDER
10-100TAN-050-3NY	1" BLAST HOSE ASSEMBLY, 50', ERGOFLEX, INCLUDES NYLON NOZZLE HOLDER (125 PSI MAX)
10-100TAN-050-3XNY	1" BLAST HOSE ASSEMBLY, 50', ERGOFLEX, INCLUDES 50mm NYLON NOZZLE HOLDER (125 PSI MAX)
10-050BLK-025-3AL	1/2" BLAST HOSE ASSEMBLY, BLACK, 25', FOR USE WITH CABINETS
10-100BLK-050-4AL	1" EXTENSION HOSE ASSEMBLY, 50'
10-114BLK-050-4AL	1-1/4" EXTENSION HOSE ASSEMBLY, 50'
27WT-1	SAFETY CABLE, 1/2" - 1" HOSE TO EQUIP.
27WC-1	SAFETY CABLE, 1/2" - 1" HOSE TO HOSE.
27WC-15	SAFETY CABLE, 1-1/4" HOSE TO HOSE.
27WT-2	SAFETY CABLE, 1-1/4" HOSE TO EQUIP.



AIR HOSE	
10-034RED-050-1	3/4" AIR HOSE ASSEMBLY, 50'
10-100RED-025-1	1" AIR HOSE ASSEMBLY, 25'
10-100RED-050-1	1" AIR HOSE ASSEMBLY, 50'
10-112RED-025-1	1-1/2" AIR HOSE ASSEMBLY, 25'
10-112RED-050-1	1-1/2" AIR HOSE ASSEMBLY, 50'
27WT-1	SAFETY CABLE, 3/4" - 1" HOSE TO EQUIP.
27WC-1	SAFETY CABLE, 3/4" - 1" HOSE TO HOSE.
27WT-2	SAFETY CABLE, 1-1/2" HOSE TO EQUIP.
27WC-2	SAFETY CABLE, 1-1/2" HOSE TO HOSE.



BREATHING EQUIPMENT	
407000-PFC	NOVA 2000™ RESPIRATOR PACKAGE
407800-PFC	ASTRO™ RESPIRATOR PACKAGE
407001	COOL TUBE
407024	HOT TUBE
407200	RADEX™ CO MONITOR (120V)
407201	RADEX™ CO MONITOR (12V)

RESPIRATOR PACKAGES INCLUDE RESPIRATOR HELMET, 50' BREATHING AIR SUPPLY HOSE, AND RADEX™ AIRLINE FILTER.



☠️ BLASTING SET-UP ☠️



NOZZLES	
1" ENTRY NOZZLES 1-1/4" THREAD	
1201-1172	#3 TUNGSTEN CARBIDE NOZZLE
1201-1173	#4 TUNGSTEN CARBIDE NOZZLE
1201-1174	#5 TUNGSTEN CARBIDE NOZZLE
1201-1175	#6 TUNGSTEN CARBIDE NOZZLE
1201-1176	#7 TUNGSTEN CARBIDE NOZZLE
WINS® (WATER INDUCTION NOZZLES)	
1410-005	WATER INDUCTION NOZZLE SYSTEM, TUNGSTEN CARBIDE, 5/16" BORE, 1" ENTRY, 1-1/4" THREAD, ALUMINUM JACKET, HOSE INCLUDED
1410-1005	WATER INDUCTION NOZZLE SYSTEM, TUNGSTEN CARBIDE, 5/16" BORE, 1" ENTRY, 50mm THREAD, ALUMINUM JACKET, HOSE INCLUDED
NOZZLES 3/4" THREAD FOR USE WITH CABINETS	
1348-614	#3 TUNGSTEN CARBIDE NOZZLE
1348-616	#4 TUNGSTEN CARBIDE NOZZLE
1348-617	#5 TUNGSTEN CARBIDE NOZZLE



BLAST SUITS / GLOVES	
122-9140	BLAST SUIT, LIGHTWEIGHT, MEDIUM
122-9150	BLAST SUIT, LIGHTWEIGHT, LARGE
122-9160	BLAST SUIT, LIGHTWEIGHT, XL
122-9170	BLAST SUIT, LIGHTWEIGHT, XXL
122-9180	BLAST SUIT, LIGHTWEIGHT, XXXL
407701	LUXURY DOUBLE PALMED LEATHER BLASTING/WELDING GLOVES



AIR DRYERS / MOISTURE SEPARATORS	
888-1310-021PB	AIR DRYER ADPB-250 CFM @ 100 PSIG OR 359 CFM @ 150 PSIG
888-1310-041PB	AIR DRYER ADPB-400 CFM @ 100 PSIG OR 574 CFM @ 150 PSIG
888-1200-08005PB	MOISTURE SEPARATOR 800 CFM, PORTABLE 150 PSI (10.3 BAR), (1) 4 LUG W/BALL VALVE INLET x (1) 4 LUG OUTLET

☠️ AVAILABLE ACCESSORIES ☠️



JOB TIMER	
KEEP TRACK OF TIME SPENT ON A JOB AND TOTAL HOURS ON YOUR ABRASIVE BLASTER, KNOW YOUR COST, CONTROL YOUR COST & SET UP A PREVENTATIVE MAINTENANCE PROGRAM FOR YOUR BLAST EQUIPMENT.	
PB-9805023P	DUAL TIMER CONTROL BOX W/ KEY RESET & MOUNTING BRACKET



PNEUMATIC



PUSH BUTTON

ABRASIVE CUT-OFF KITS	
ADD AN ABRASIVE CUT-OFF CONVERSION KIT TO YOUR SPH SERIES ABRASIVE BLASTER ALLOWING YOU TO BLOW OFF YOUR PROJECT WITH THE SAME HIGH VELOCITY AIR YOU BLAST WITH	
888-2035-00101PB	55' PNEUMATIC ABRASIVE CUT-OFF KIT
888-2035-00202PB	PALM BUTTON ABRASIVE CUT-OFF KIT



RELIEF VALVE KIT	
ADDING THIS ASME RELIEF VALVE KIT TO YOUR BLASTER CAN PREVENT DANGEROUS OVERPRESSURIZATION. LOCAL CODES MAY REQUIRE A DIFFERENT VALVE	
888-2470-00702PB	SMALL BLASTER RELIEF VALVE KIT



SODA STORM™ BLASTERS - USER'S MANUAL

BLASTING CHARTS

Nozzle Air, Power & Abrasive Requirements

NOZZLE # ORIFICE SIZE	NOZZLE AIR, POWER & ABRASIVE REQUIREMENTS	NOZZLE PRESSURE								
		50 PSI	60 PSI	70 PSI	80 PSI	90 PSI	100 PSI	125 PSI	140 PSI	
		(3.45 BAR)	(4.14 BAR)	(4.83 BAR)	(5.52 BAR)	(6.21 BAR)	(6.89 BAR)	(8.62 BAR)	(9.65 BAR)	
#2 1/8 inch (3.2 mm)	AIR	(cu ft/min)	12	13	15	18	19	21	26	
		(cu m/min)	0.34	.037	0.42	0.51	0.54	0.59	0.74	
	HORSEPOWER	(hp)	1.75	2	2.5	3	3.5	4	6	
		(kW)	1.30	1.49	1.86	2.24	2.61	2.98	4.47	
	ABRASIVE	(lb/hr)	70	80	90	100	110	120	135	
		(kg/hr)	32	36	41	45	50	54	61	
#3 3/16 inch (4.8 mm)	AIR	(cu ft/min)	25	30	35	40	43	45	60	
		(cu m/min)	0.71	0.85	0.99	1.13	1.22	1.27	1.70	
	HORSEPOWER	(hp)	5	8	9	9.5	10	10.5	16	
		(kW)	3.75	5.97	6.71	7.08	7.46	7.86	11.93	
	ABRASIVE	(lb/hr)	150	170	200	215	240	260	320	
		(kg/hr)	68	77	91	98	109	118	145	
#4 1/4 inch (6.35 mm)	AIR	(cu ft/min)	50	55	60	70	75	80	95	
		(cu m/min)	1.42	1.56	1.70	1.98	2.12	2.27	2.69	
	HORSEPOWER	(hp)	10	12	13	16	17	18	25	
		(kW)	7.46	8.95	9.69	11.93	12.68	13.42	18.64	
	ABRASIVE	(lb/hr)	270	300	350	400	450	500	675	
		(kg/hr)	122	136	159	181	204	227	306	
#5 5/16 inch (8 mm)	AIR	(cu ft/min)	80	90	100	115	125	140	190	230
		(cu m/min)	2.27	2.55	2.83	3.26	3.54	3.96	5.38	6.51
	HORSEPOWER	(hp)	17	20	25	27	28	30	36	60
		(kW)	12.68	14.91	18.64	20.13	20.88	22.37	26.85	44.85
	ABRASIVE	(lb/hr)	470	530	600	675	750	825	1000	1125
		(kg/hr)	213	240	272	306	340	374	454	510
#6 3/8 inch (9.5 mm)	AIR	(cu ft/min)	110	125	145	160	175	200	275	315
		(cu m/min)	3.12	3.54	4.11	4.53	4.96	5.66	7.79	8.91
	HORSEPOWER	(hp)	25	29	32	35	40	45	57	65
		(kW)	18.64	21.63	23.86	26.10	29.83	33.56	42.50	48.59
	ABRASIVE	(lb/hr)	675	775	875	975	1060	1100	1350	1840
		(kg/hr)	306	352	397	442	481	499	612	835
#7 7/16 inch (9.5 mm)	AIR	(cu ft/min)	150	170	200	215	240	255	315	405
		(cu m/min)	4.25	4.81	5.66	6.09	6.80	7.22	8.92	11.46
	HORSEPOWER	(hp)	35	40	45	50	55	60	70	90
		(kW)	26.10	29.83	33.56	37.28	41.01	44.74	52.20	67.28
	ABRASIVE	(lb/hr)	900	1000	1200	1300	1400	1510	1800	2540
		(kg/hr)	408	454	544	590	635	703	816	1152
#8 1/2 inch (12.7 mm)	AIR	(cu ft/min)	200	225	250	275	300	340	430	540
		(cu m/min)	5.66	6.37	7.08	7.79	8.50	9.63	12.18	15.28
	HORSEPOWER	(hp)	45	50	55	63	70	75	95	120
		(kW)	33.56	37.28	41.01	46.98	52.20	55.93	70.84	89.70
	ABRASIVE	(lb/hr)	1200	1350	1500	1700	1850	2025	2525	3240
		(kg/hr)	544	612	680	771	839	919	1145	1470
#10 5/8 inch (16 mm)	AIR	(cu ft/min)	300	350	400	450	500	550	700	880
		(cu m/min)	8.50	9.91	11.33	12.74	14.16	15.58	19.82	24.90
	HORSEPOWER	(hp)	70	80	90	100	110	120	150	190
		(kW)	52.20	59.66	67.11	74.57	82.03	89.48	111.85	142.02
	ABRASIVE	(lb/hr)	1900	2200	2400	2700	3000	3300	4000	5200
		(kg/hr)	862	998	1089	1225	1361	1497	1814	2359
#12 3/4 inch (19 mm)	AIR	(cu ft/min)	430	500	575	650	700	800	1100	1255
		(cu m/min)	12.18	14.16	16.28	18.41	19.82	22.66	31.15	35.52
	HORSEPOWER	(hp)	100	115	130	145	160	175	215	245
		(kW)	74.57	85.76	96.94	108.13	119.31	130.50	160.33	183.13
	ABRASIVE	(lb/hr)	2700	3100	3500	3900	4300	4700	5700	7375
		(kg/hr)	1225	1406	1588	1769	1950	2132	2586	3345

This table is to be used as reference only. Actual results may vary depending on specific abrasive medium used. This table is based on abrasive with a bulk density of 100 pounds per cubic foot.