

www.ESP.swisherinc.com

# OWNER'S MANUAL

## SRAC20229 Double Panel Bench

Starting Serial #: L115-001001

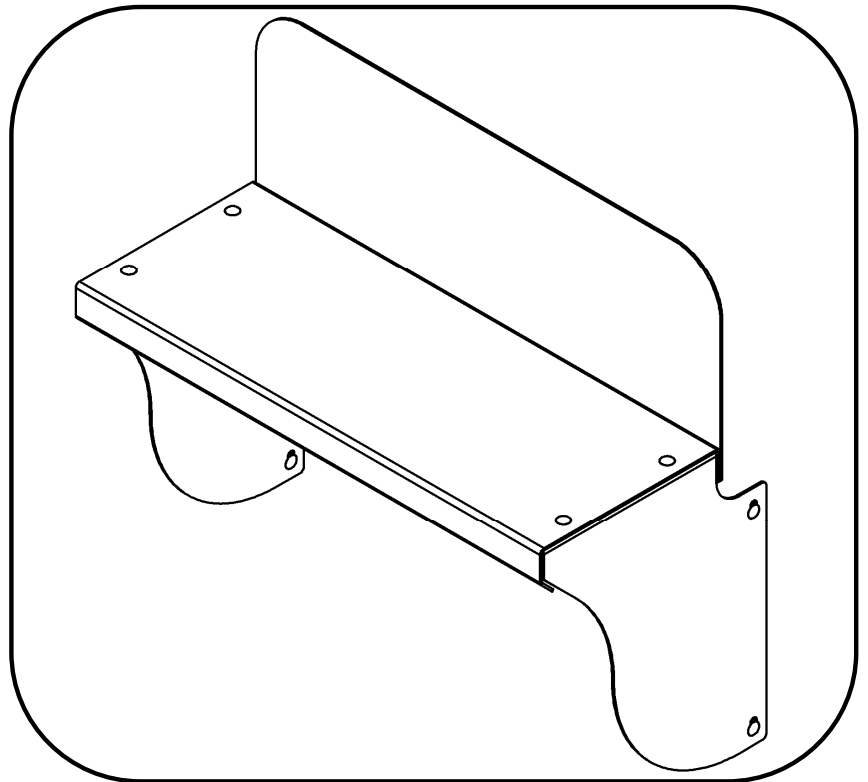

**E**MERGENCY  
**S**ECURITY  
**P**REPAREDNESS  
**SAFETY SHELTER**

# ACCESSORIES

SWISHER ACQUISITION INC.  
1602 CORPORATE DRIVE, WARRENSBURG, MISSOURI 64093  
PHONE 660-747-8183 FAX 660-747-8650

Made In The  
**USA**  
of US and Global Parts

## LIMITED WARRANTY

The manufacturer's warranty to the original consumer purchaser is: This product is free from defects in materials and workmanship for a period of one (1) year from the date of purchase by the original consumer purchaser. We will repair or replace, at our discretion, parts found to be defective due to materials or workmanship. This warranty is subject to the following limitations and exclusions:

- 1)      Limitation                    This warranty applies only to products which have been properly assembled, adjusted, and operated in accordance with the instructions contained within this manual. This warranty does not apply to any product of Swisher that has been subject to alteration, misuse, abuse, improper assembly or installation, shipping damage, or to normal wear of product.
- 2)      Exclusions                     Excluded from this warranty are normal wear, normal adjustments, and normal maintenance.

All transportation charges, damage, or loss incurred during transportation of parts submitted for replacement or repair under this warranty shall be borne by the purchaser. Should you have any questions concerning this warranty, please contact us toll-free at 1-800-222-8183. The model number, serial number, date of purchase, and the name of the authorized Swisher dealer from whom you purchased the product will be needed before any warranty claim can be processed.

**THIS WARRANTY DOES NOT APPLY TO ANY INCIDENTAL OR CONSEQUENTIAL DAMAGES AND ANY IMPLIED WARRANTIES ARE LIMITED TO THE SAME TIME PERIODS STATED HEREIN FOR ALL EXPRESSED WARRANTIES.** Some states do not allow the limitation of consequential damages or limitations on how long an implied warranty may last, so the above limitations or exclusions may not apply to you. This warranty gives you specific legal rights and you may have other rights, which vary from state-to-state. This is a limited warranty as defined by the Magnuson-Moss Act of 1975.

## **Safety Precautions**

- NEVER allow children to play in or around the Safety Shelter.
- NEVER store flammable materials or fuel in your Safety Shelter.
- Keep a flashlight(s) or other battery operated lights inside the Safety Shelter. Check or replace the batteries in these lights twice per year.
- Do not store any items in a manner that would block any of the Safety Shelter vents.
- We suggest stocking your Safety Shelter with provisions and supplies so that it is ready when needed.
- During a high wind event occupants **MUST** stay at least 3” away from the walls and door and remove all loose items from shelves and walls by placing them on the floor to avoid potential injury from debris impact.
- Do not stand on the bench or use it as a step.
- Recommended weight capacity 350 lbs.

### **Recommended Tools For Assembly:**

- Leather Gloves
- Safety Glasses
- Flashlight
- (1) Torque Wrench Capable of 31 Ft-lbs
- (1) 9/16” Socket
- (1) 1/2” Open End Wrench or Socket Wrench
- (2) 7/16” Open End Wrench or Socket Wrench

Tip: If you're adding this Accessory to an existing Safety Shelter, remove the appropriate original nuts and bolts from the Wall Panels and replace them with the hardware provided with the Accessory.

This Bench is designed to be installed on two wall panels of ESP Safety Shelters.

# Parts List

Item #	Part #	Description
1	20230*	Seat - Double Panel Bench
2	20236	Bolt - Carriage 5/16-18 X .75
3	20231*	Back - Double Panel Bench
4	20237	Nut - Serr Flange 5/16-18
5	19799	Nut - Serr Flange, Hex 3/8-16
6	20234*	Side - Bench, Left
7	19828	Bolt - Carriage 3/8-16 X 1
8	20233*	Side - Bench, Right

Step 1

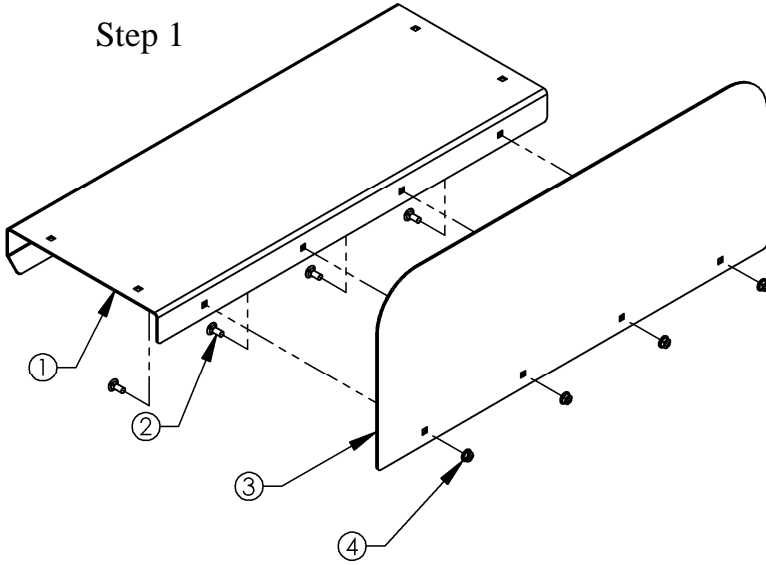

Step 2

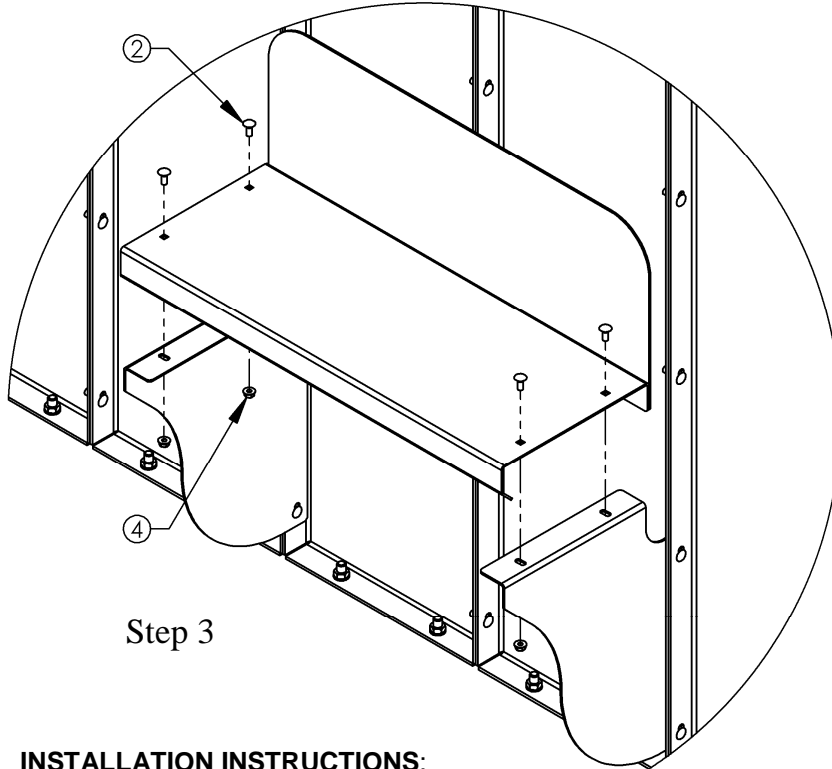
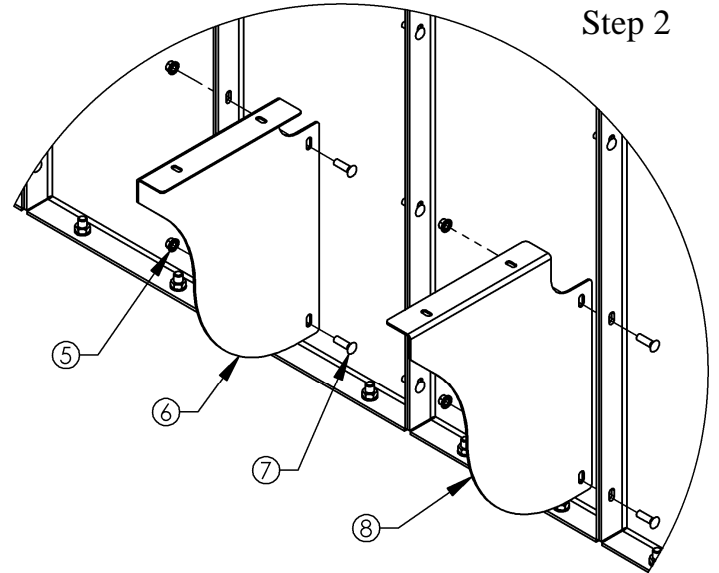

Step 3

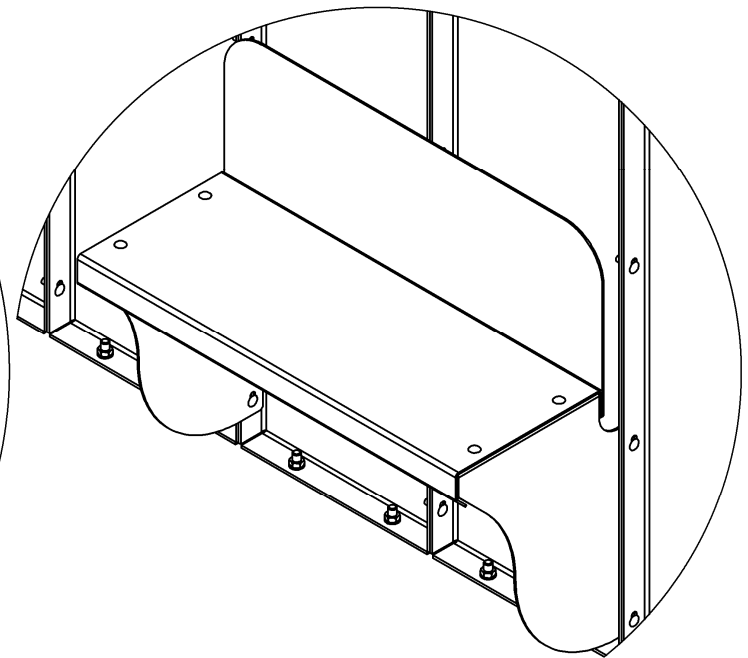

## INSTALLATION INSTRUCTIONS:

1. Assemble Seat 20230 to Back 20231 using 5/16-18 X .75 Bolt 20236 and 5/16-18 Nut 20237.
2. Attach Left Side Panel 20234 and Right Side Panel 20233 to the flanges of two of the wall panels using 3/8-16 Nut 19799 and 3/8-16 X 1 Bolt 19828. Make sure to tighten this hardware to 31 Ft-lbs.
3. Next, connect the Seat & Back assembly to the Side Panels using 5/16-18 X .75 Bolt 20236 and 5/16-18 Nut 20237.

When ordering replacement parts:

\*= USE PAINT CODE: GT=GREY

# ALSO AVAILABLE

Visit [www.ESP.swisherinc.com](http://www.ESP.swisherinc.com) for details.

Single Panel Shelf

SRAC20221

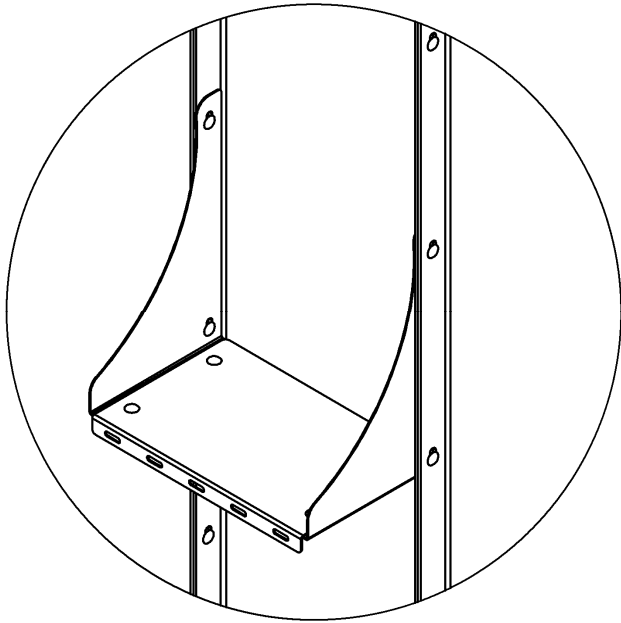

Double Panel Shelf

SRAC20226

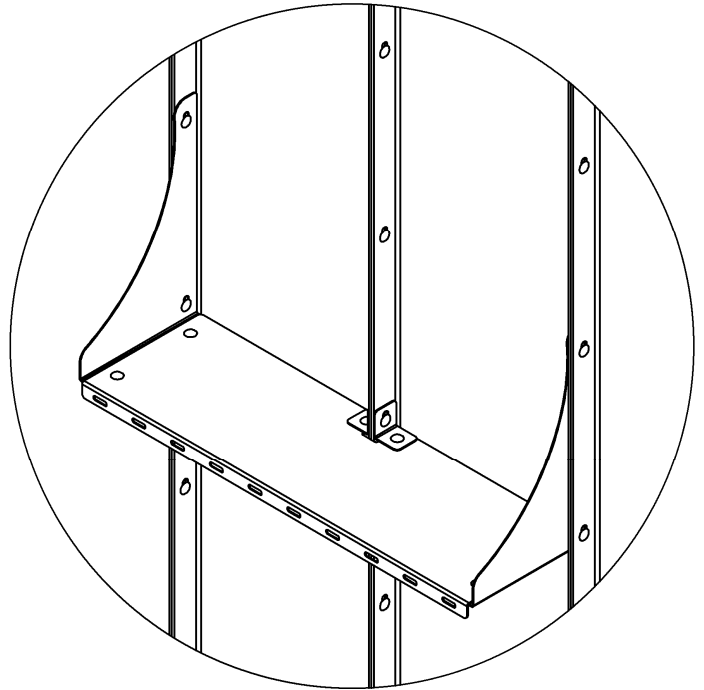

Gun Rack

SRAC20282

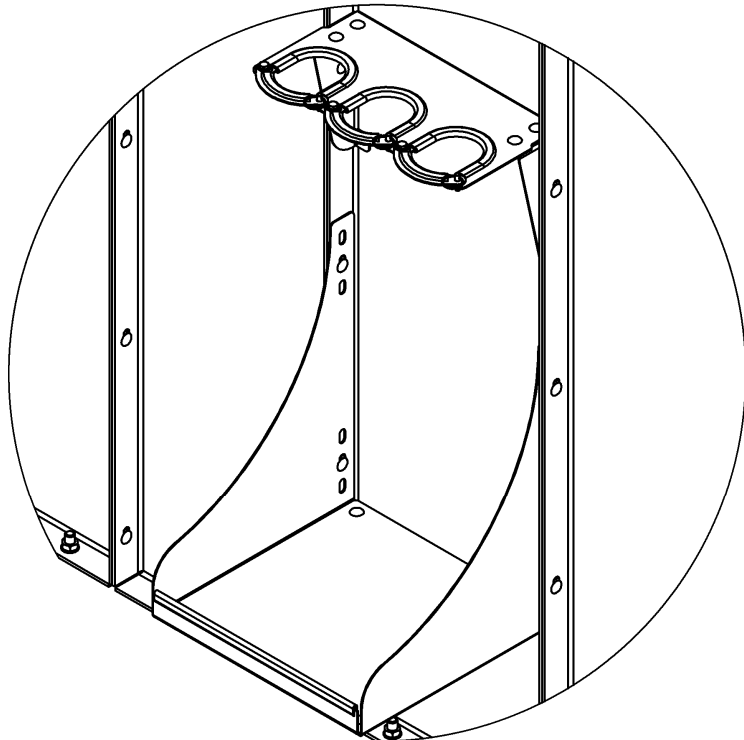

Adjustable Gun Rack

SRAC20338

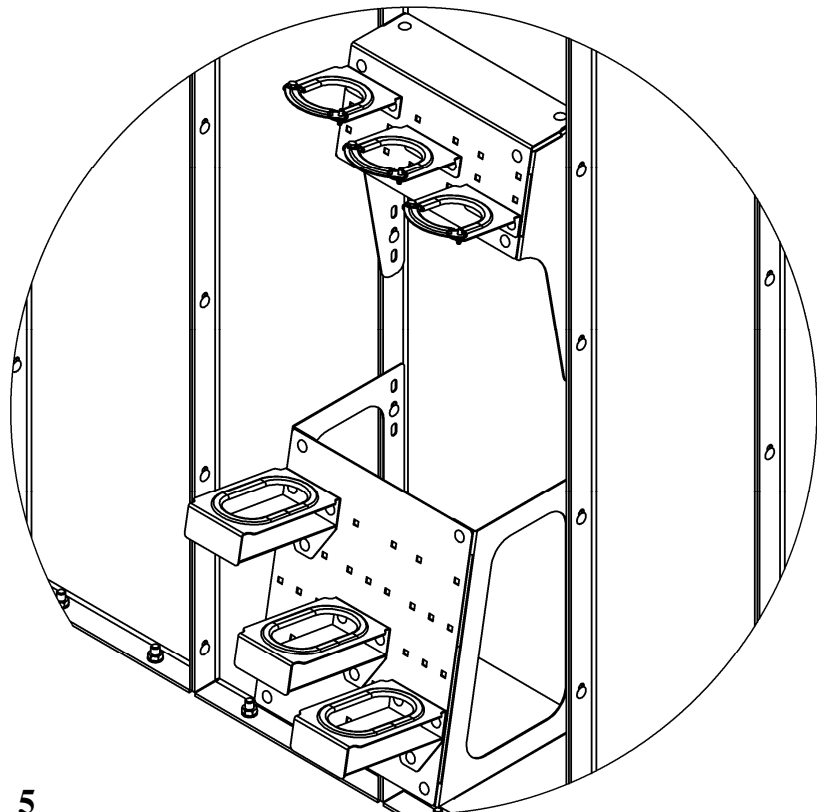

# ALSO AVAILABLE

Visit [www.ESP.swisherinc.com](http://www.ESP.swisherinc.com) for details.

Dorcy Motion Sensor Light

SRAC20389



FLEXiT Light

SRAC20270



Kaito Emergency Radio

SRAC20390



Eva-Dry Dehumidifier, up to 500 cu-ft

SRAC19840





www.ESP.swisherinc.com

# OWNER'S MANUAL

## SRAC20229 Double Panel Bench

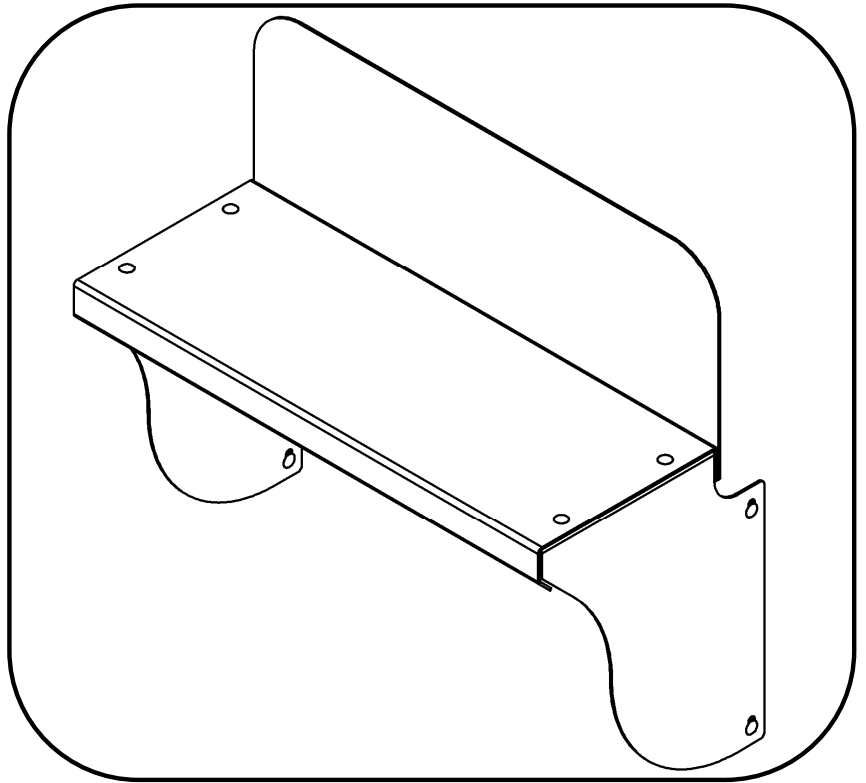

# **E**MERGENCY **S**ECURITY **P**REPAREDNESS **SAFETY SHELTER** **ACCESSORIES**

WHEN ORDERING PARTS, PLEASE HAVE THE  
FOLLOWING INFORMATION AVAILABLE:

- \* PRODUCT - \_\_\_\_\_
- \* SERIAL NUMBER - \_\_\_\_\_
- \* MODEL NUMBER - \_\_\_\_\_
- \* PART NUMBER WITH PAINT CODE
- \* PART DESCRIPTION

TELEPHONE - 1-800-222-8183  
FAX - 1-660-747-8650

**SWISHER ACQUISITION INC.**  
1602 CORPORATE DRIVE  
WARRENSBURG, MO 64093