

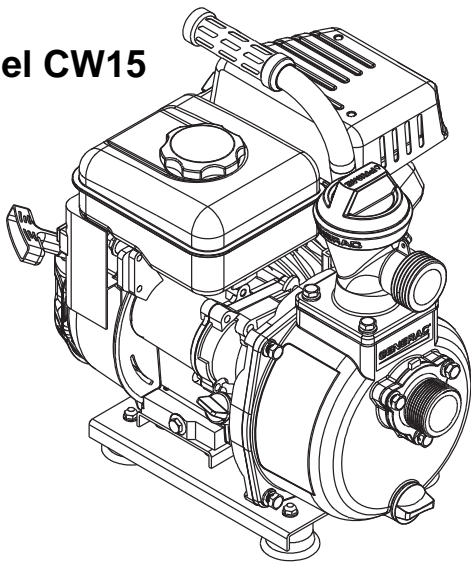

# *Owner's Manual*

## *Water Pump*

**Model CW15**



**Model ST20**

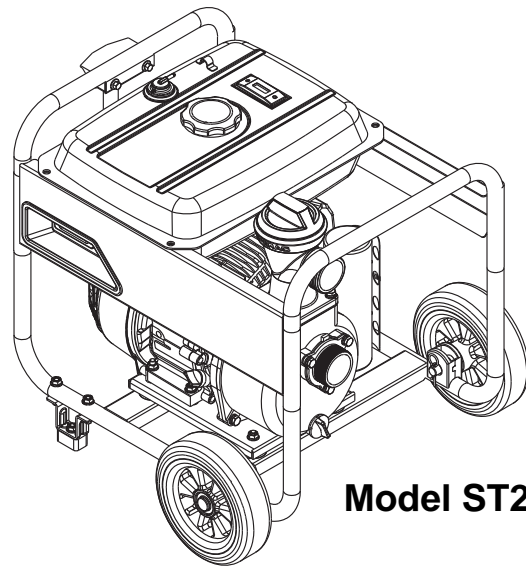

<b>Model Number</b>	
<b>Serial Number</b>	

**www.generac.com or 1-888-436-3722**

**WARNING!**

**California Proposition 65**

Engine exhaust and some of its constituents are known to the state of California to cause cancer, birth defects, and other reproductive harm.

**WARNING!**

**California Proposition 65**

This product contains or emits chemicals known to the state of California to cause cancer, birth defects, and other reproductive harm.

# Table of Contents

Section 1 - Introduction	
1.1 - Introduction . . . . .	1
Section 2 - Safety	
2.1 - Safety Rules . . . . .	3
Section 3 - General Information	
3.1 - Know Your Water Pump . . . . .	7
3.2 - Product Specifications . . . . .	9
3.3 - Emissions Information . . . . .	9
3.4 - High Altitude Operation . . . . .	9
3.5 - Unpacking . . . . .	9
Section 4 - Set-up	
4.1 - Assembly . . . . .	11
4.2 - Add Engine Oil . . . . .	12
4.3 - Fuel . . . . .	12
4.4 - Connect Suction and Discharge Hose . . . . .	13
4.5 - Prime the Unit . . . . .	13
Section 5 - Operation	
5.1 - Operation . . . . .	15
5.2 - Water Pump Location . . . . .	15
5.3 - Checklist Before Starting Engine . . . . .	16
5.4 - How to Start Your Water Pump . . . . .	16
5.5 - How to Stop Your Water Pump . . . . .	17
Section 6 - Maintenance	
6.1 - Maintenance Recommendations . . . . .	19
6.2 - Maintenance Schedule . . . . .	19
6.3 - Emissions Control . . . . .	19
6.4 - Water Pump Maintenance . . . . .	20
6.5 - Check Hose Filter . . . . .	20
6.6 - Check Hoses . . . . .	20
6.7 - Engine Maintenance . . . . .	20
6.8 - Engine Oil Recommendations . . . . .	20
6.9 - Service Air Cleaner . . . . .	21
6.10 - Service Spark Plug . . . . .	22
6.11 - After Each Use . . . . .	22
6.12 - Long Term Storage . . . . .	22
6.13 - Other Storage Instructions . . . . .	23
6.14 - Transporting/Tipping of the Unit . . . . .	23
Section 7 - Troubleshooting	
7.1 - Troubleshooting Guide . . . . .	31



---

# Section 1 *Introduction*

---

## 1.1 — INTRODUCTION

Thank you for purchasing this water pump manufactured by Generac Power Systems, Inc. This is a high performance, air-cooled, engine-driven water pump that operates at 80 or 158 GPM depending on model.

**Common sense and strict compliance with the special instructions are essential to preventing accidents.** The operator must read this manual and thoroughly understand all of the instructions and warnings before using the equipment. If any portion of the manual is not understood, contact the nearest Authorized Dealer for starting, operating and servicing procedures. The owner is responsible for proper and safe use of the equipment.

The water pump can operate safely, efficiently and reliably only if it is properly located, operated and maintained. Before operating, servicing or storing:

- Study all warnings in this manual and on the product carefully.
- Become familiar with this manual and the unit before use.
- Refer to the Assembly section of the manual for instructions on final assembly procedures. Follow the instructions completely.

The manufacturer cannot anticipate every possible circumstance that might involve a hazard. The warnings in this manual, and on tags and decals affixed to the unit are, therefore, not all inclusive. If using a procedure, work method or operating technique that the manufacturer does not specifically recommend, ensure that it is safe for others. Also make sure the procedure, work method or operating technique utilized does not render the water pump unsafe.

THE INFORMATION CONTAINED HEREIN WAS BASED ON MACHINES IN PRODUCTION AT THE TIME OF PUBLICATION. GENERAC RESERVES THE RIGHT TO MODIFY THIS MANUAL AT ANY TIME.

**Save these instructions. If you loan this device to someone, always loan these instructions and Owner's Manual to individual as well.**

## 1.1.1 — Where to Find Us

You can contact Generac Customer Service by phone at 1-888-436-3722, or on the internet at [www.generac.com](http://www.generac.com). Record model and serial number of unit on front cover for future reference and/or service inquiries.

**This page intentionally left blank.**

# Section 2 **Safety**

## 2.1 — SAFETY RULES

Throughout this publication, and on tags and decals affixed to the water pump, DANGER, WARNING, CAUTION and NOTE blocks are used to alert personnel to special instructions about a particular operation that may be hazardous if performed incorrectly or carelessly. Observe them carefully. Their definitions are as follows:

### **⚠ DANGER!**

Indicates a hazardous situation or action which, if not avoided, will result in death or serious injury.

### **⚠ WARNING!**

Indicates a hazardous situation or action which, if not avoided, could result in death or serious injury.

### **⚠ CAUTION!**

Indicates a hazardous situation or action which, if not avoided, could result in minor or moderate injury.

**NOTE:** Notes contain additional information important to a procedure and will be found within the regular text body of this manual.

These safety warnings cannot eliminate the hazards that they indicate. Common sense and strict compliance with the special instructions while performing the action or service are essential to preventing accidents. Safety Symbols and Meanings.

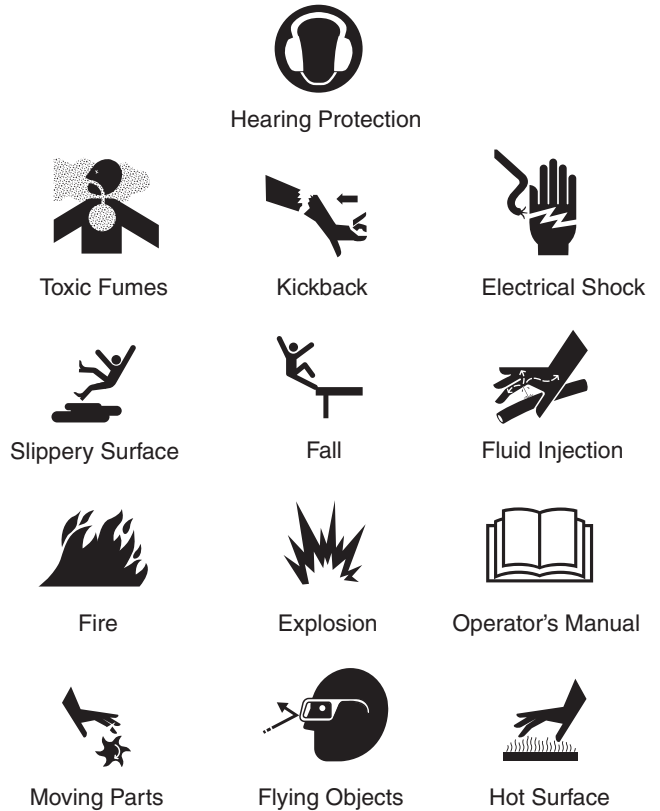

**⚠ DANGER**

**Using engine powered equipment indoors CAN KILL YOU IN MINUTES.**

Engine exhaust contains carbon monoxide. This is a poison you cannot see or smell.

**NEVER** use inside a home or garage, **EVEN IF** doors and windows are open.

Only use **OUTSIDE** and far away from windows, doors, and vents.

**Figure 2-1. Exhaust Hazard**

### 2.1.1 — Exhaust Hazards

#### **⚠ DANGER!**



**Carbon monoxide produced during use can kill in minutes. NEVER use indoors, in a vehicle, or in other sheltered areas, EVEN IF doors and windows are open. Only use OUTSIDE and far away from windows, doors and vents.**

- Operate water pump ONLY outdoors.
- A running engine gives off carbon monoxide.
- Carbon monoxide is an odorless, colorless, poisonous gas. Breathing carbon monoxide can cause headache, fatigue, dizziness, vomiting, confusion, seizures, nausea, fainting or death. If you start experiencing any of these symptoms, IMMEDIATELY move to fresh air. Seek medical attention.
- Keep exhaust gas from entering a confined area through windows, doors, ventilation intakes, or other openings. Warn any occupants inside about the symptoms of carbon monoxide so they know to move to fresh air if they begin to feel ill.
- The use of a carbon monoxide detector inside any occupied premises between the water pump and the occupant is recommended.
- NEVER start or run engine indoors, in a vehicle, or in an enclosed area, even if windows and doors are open.
- Use a respirator or mask whenever there is a chance that harmful gas or vapors may be inhaled.
- Read all instructions with respirator or mask so you are certain the respirator or mask will provide the necessary protection against inhaling harmful gas or vapors. If you begin to experience any of the CO symptoms listed above, IMMEDIATELY move to fresh air.

### 2.1.2 — Electrical Shock Hazard

#### **⚠ WARNING!**



**Risk of electrocution.**

**Contact with power source can cause electric shock or burn.**

- NEVER have discharge hose near power source.

### 2.1.3 — Hot Surfaces Hazard

#### **⚠ WARNING!**



**Contact with muffler area can result in serious burns. Exhaust heat/gases can ignite combustibles, structures or damage fuel tank causing a fire.**

- DO NOT touch hot parts and AVOID hot exhaust gases.
- Allow equipment to cool before touching.
- Keep at least five (5) feet (152 cm) of clearance on all sides of water pump including overhead.
- It is a violation of California Public Resource Code, Section 4442, to use or operate the engine on any forest-covered, brush-covered, or grass-covered land unless the exhaust system is equipped with a spark arrester, as defined in Section 4442, maintained in effective working order. Other states or federal jurisdictions may have similar laws. Contact the original equipment manufacturer, retailer, or dealer to obtain a spark arrester designed for the exhaust system installed on this engine.
- Replacement parts must be the same and installed in the same position as the original parts.

### 2.1.4 — Fire Hazards

#### **⚠ WARNING!**



**Fuel and its vapors are extremely flammable and explosive. Fire or explosion can cause severe burns or death.**

#### **WHEN ADDING OR DRAINING FUEL**

- Turn water pump OFF and let it cool at least two (2) minutes before removing fuel cap. Loosen cap slowly to relieve pressure in tank.
- Fill or drain fuel tank outdoors.
- DO NOT overfill tank. Allow space for fuel expansion.
- If fuel spills, wait until it evaporates before starting engine.
- Keep fuel away from sparks, open flames, pilot lights, heat, and other ignition sources.
- DO NOT light a cigarette or smoke.

#### **WHEN STARTING EQUIPMENT**

- Ensure spark plug, muffler, fuel cap, and air cleaner are in place.
- DO NOT crank engine with spark plug removed.
- Keep your hands and body clear from the discharge of the pump.
- Make sure all connections are tight.
- Secure the pump. Loads from the hoses may cause it to tip over.
- Secure the discharge hose to avoid whipping.

#### **WHEN OPERATING EQUIPMENT**

- DO NOT tip engine or equipment at angle which causes fuel to spill.



- DO NOT pump chemicals or flammable liquids, such as fuel, or fuel oils.
- Reflective exhaust heat may damage the fuel tank, causing fire. Keep at least 5 feet of clearance on all sides of the pump for adequate cooling, maintenance, and servicing.
- DO NOT use to pump fluid intended for human consumption.
- Secure the pump. Loads from the hoses may cause it to tip over.
- DO NOT stop the engine by moving the choke lever to the CHOKE position.
- Wear ear protection to reduce objectionable noise.

#### WHEN TRANSPORTING OR REPAIRING EQUIPMENT

- Transport/repair with fuel tank EMPTY.
- Disconnect spark plug wire.

#### WHEN STORING FUEL OR EQUIPMENT WITH FUEL IN TANK

- Store away from furnaces, stoves, water heaters, clothes dryers, or other appliances that have pilot light or other ignition source because they can ignite fuel vapors.

### ⚠ CAUTION!

- DO NOT operate this pump dry!
- Excessively high operating speeds increase risk of injury and damage to pump.
- Excessively low speeds impose a heavy load.
- DO NOT tamper with the governed speed.
- DO NOT modify the pump in any way.
- DO NOT allow unqualified persons or children to operate or service pump.
- DO NOT insert any objects through cooling slots.
- Treating the pump improperly can damage it and shorten its life.
- Be sure pump chamber is filled with water before starting the engine. NEVER run pump without priming.
- Use a non-collapsible hose on the suction side of the pump.
- Use the pump only for its intended uses.

#### 2.1.5 — Hearing Protection Hazard

### ⚠ WARNING!



**Hearing Protection Recommended.**

#### 2.1.6 — Fall Hazard

### ⚠ WARNING!



**Use of water pump can create puddles and slippery surfaces.**

- Use only on a level surface.
- The area should have adequate slopes and drainage to reduce the possibility of a fall due to slippery surfaces.
- Do not use on elevated surfaces where there could be a chance of a serious fall.

#### 2.1.7 — Moving Parts Hazard

### ⚠ WARNING!



**Starter and other rotating parts can entangle hands, hair, clothing, or accessories.**

- NEVER operate water pump without protective housing or covers.
- DO NOT wear loose clothing, jewelry or anything that may be caught in the starter or other rotating parts.
- Tie up long hair and remove jewelry.

#### 2.1.8 — Kickback Hazard

### ⚠ WARNING!



**Starter cord kickback (rapid retraction) can result in bodily injury. Broken bones, fractures, bruises, or sprains could result.**

- When starting engine, pull cord slowly until resistance is felt and then pull rapidly to avoid kickback.

#### 2.1.9 — Spark Hazards

### ⚠ WARNING!



**Unintentional sparking can result in fire or electric shock.**

**WHEN ADJUSTING OR MAKING REPAIRS TO YOUR WATER PUMP.**

- Disconnect the spark plug wire from the spark plug and place the wire where it cannot contact spark plug.

#### WHEN TESTING FOR ENGINE SPARK

- Use approved spark plug tester.
- DO NOT check for spark with spark plug removed.

---

## 2.1.10 — Splash Hazards

**⚠ WARNING!**

**Risk of eye injury. Spray can splash back or propel objects.**

- Always wear safety goggles when using this equipment or in vicinity of where equipment is in use.
- Before starting the water pump, be sure you are wearing adequate safety goggles.
- NEVER substitute safety glasses for safety goggles.

**NOTE: Improper treatment of water pump can damage it and shorten its life.**

- If you have questions about intended use, ask dealer or contact qualified service center.
- NEVER operate units with broken or missing parts, or without protective housing or covers.
- DO NOT by-pass any safety device on this machine.
- DO NOT operate water pump above rated head.
- DO NOT modify water pump in any way.
- Before starting water pump in cold weather, check all parts of the equipment to be sure ice has not formed.
- NEVER move machine by pulling on hoses. Use handle provided on unit.
- Check fuel system for leaks or signs of deterioration, such as chafed or spongy hose, loose or missing clamps, or damaged tank or cap. Correct all defects before operating water pump.
- This equipment is designed to be used with Generac authorized parts ONLY. If equipment is used with parts that DO NOT comply with minimum specifications, user assumes all risks and liabilities.

---

## Section 3 **General Information**

---

### 3.1 — KNOW YOUR WATER PUMP

Read this owner's manual and safety rules before operating your water pump. If you loan this device to someone, ALWAYS loan these instructions AND the owner's manual to the individual as well. Compare the illustrations with your water pump to familiarize yourself with the locations of various controls (Figure 3-1). Save this manual for future reference. Replacement owner's manuals can be printed from the Generac Web site.

- A - Lifting Handle** - Used to lift the water pump.
- B - Discharge Port** - Location to attach discharge hose.
- C - Suction Port** - Location to attach suction hose.
- D - Water Drain Plug** - Used to empty the water pump after use.
- E - Oil Fill** - Check and add engine oil
- F - Oil Drain Plug** - Used to drain engine oil.
- G - Muffler** - Where hot exhaust gas exits the water pump.
- H - Fuel Tank** - Fill tank with regular unleaded fuel. Always leave room for fuel expansion.
- I - Choke** - Prepares a cold engine for starting.
- J - Air Filter** - Protects engine by filtering dust and debris out of the intake air.

- K - Recoil Starter** - Used for starting the engine.
- L - Engine ON/OFF Switch** - Turn switch to ON before using recoil starter. Turn switch to Off to stop engine.
- M - Priming Cap** - Remove cap and fill the pump with water before starting the unit.
- N - Fuel Gauge** - Indicates the amount of fuel remaining in the fuel tank.
- O - Fuel On/Off Valve** - Turns fuel supply to the engine on and off.
- P - Throttle Lever** - Increases or decreases engine speed.
- Q - Serial number location**
- R - Blue Discharge Hose** - Used to discharge water from the pump
- S - Hose Clamps** - Secure the hose to the hose barbs and the filter
- T - Hose Nut** - Secures the hose barb to the pump
- U - Hose Barb** - Holds the hose to the pump
- V - Sealing Ring** - Prevents leaking
- W - Green Suction Hose** - Used to bring water into the pump
- X - Filter Attachment** - Used to connect filter basket to the suction hose.
- Y - Filter Basket** - Used to keep debris out of the pump.

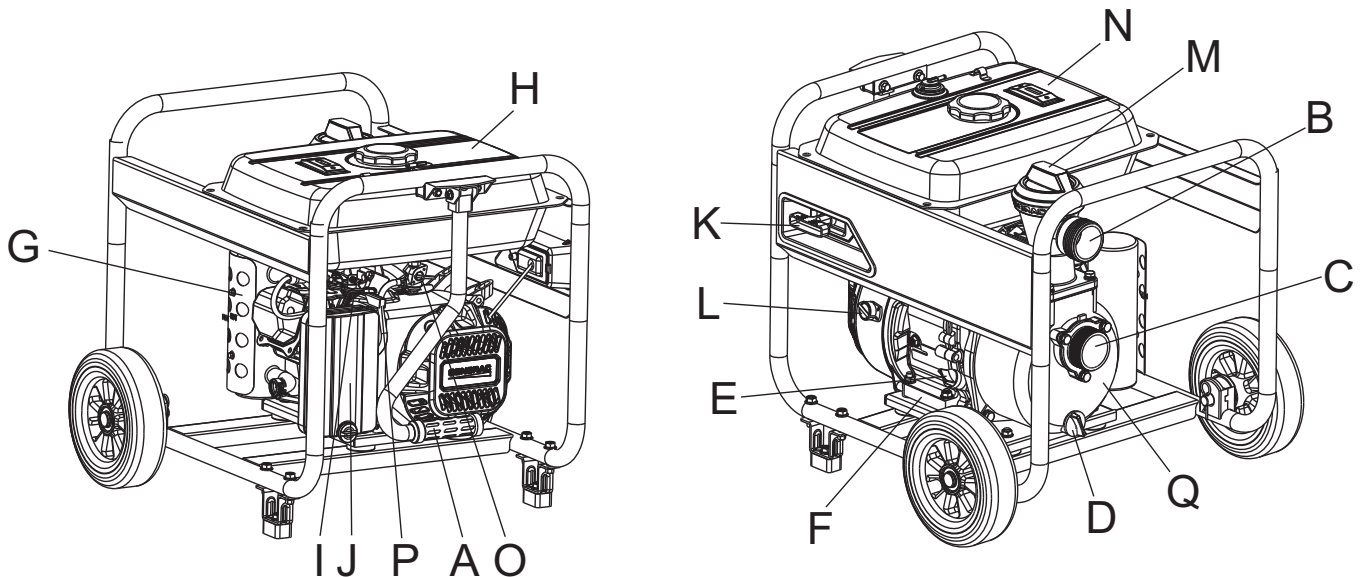

**Figure 3-1. ST20 Features and Controls**

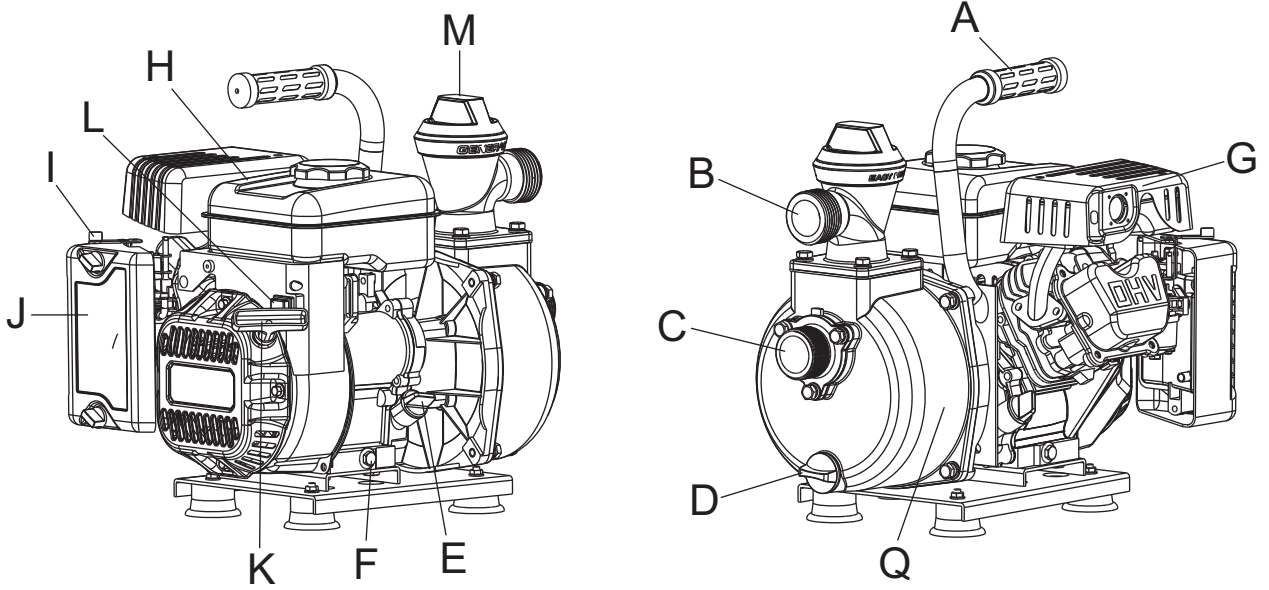

**Figure 3-2. CW15 Features and Controls**

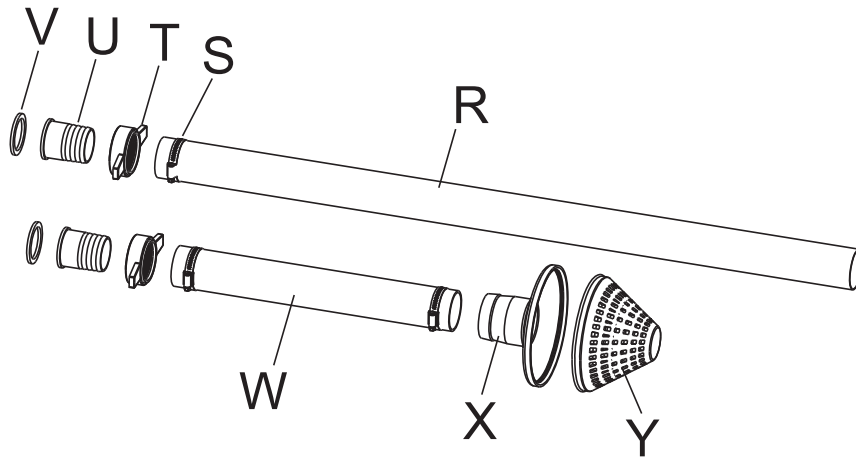

**Figure 3-3. Features and Controls**

### 3.2 — PRODUCT SPECIFICATIONS

Model	CW15K	ST20K
Flow Rate (GPM / LPM)	80/303	158/598
Suction/Discharge Diameter (Inches/mm)	1.5/40	2/50
Total Head (feet/meter)	80/24.4	108/32.9
Suction Head (feet/meter)	26/7.9	26/7.9
Suction Hose Length (feet/meters)	10/3.1	12/3.7
Discharge Hose Length (feet/meters)	25/7.6	25/7.6
Engine Displacement (Cubic Inch/cc)	4.8/79	12.7/208
Spark Plug Type	E6RTC or Equivalent	F6RTC or Equivalent
Spark Plug Gap (Inches/mm)	0.028-0.031 / 0.70-0.80	
Fuel Capacity (Gallon/Liters)	0.4/1.5	3/11.5
Oil Capacity (Oz/Liters)	13.5/0.4	20/0.6
Low Oil Shut Down System	No	Yes
On/Off Switch	Yes	

### 3.3 — EMISSIONS INFORMATION

The U.S. Environmental Protection Agency (and California Air Resource Board for equipment certified to CA standards) requires that this engine comply with exhaust and evaporative emission standards. Locate the emissions compliance decal on the engine to determine what standards the engine meets, and to determine which emissions warranty applies. The engine is certified to meet the applicable emission standards on gasoline. It is important to follow the maintenance specifications in the Maintenance section to ensure that the engine complies with the applicable emission standards for the duration of the product's life. This engine utilizes lean carburetion settings and other systems to reduce emissions. Tampering with or altering the emission control system may increase emissions and may be a violation of Federal or California Law. Acts that constitute tampering include but are not limited to:

- Removal or alteration of any part of the intake, fuel, or exhaust systems
- Altering or defeating the governor linkage or speed-adjusting mechanism to cause the engine to operate outside its design parameters

If you are aware of any of the following symptoms, have your engine inspected and repaired by your servicing dealer:

- Hard starting or stalling after starting
- Rough idle
- Misfiring or backfiring under load
- Afterburning (backfiring)
- Black exhaust smoke or high fuel consumption

### 3.4 — HIGH ALTITUDE OPERATION

The fuel system on this engine may be influenced by operation at higher altitudes.

### 3.5 — UNPACKING

1. Remove the loose parts, kits, and inserts included with water pump.
2. Open carton completely by cutting each corner from top to bottom.
3. Ensure you have all included items prior to assembly.
  - Main Unit
  - Hose Kit
    - Suction Hose
    - Discharge Hose
    - Hose Filter
    - Hose Nut (2)
    - Hose Clamp (3)
    - Hose Barb (2)
    - Sealing Ring (2)
  - Loose Parts
    - Oil Bottle
    - Funnel
    - Spark Plug wrench
    - Operator's Manual
    - Owner's Registration Card
  - Wheel Kit (ST20K only)
    - 8 inch wheel (2)
    - Stub Axle (2)
    - Washer (2)
    - Cotter Pin (2)
    - Handle
    - Foot Bracket (2)
    - M8x40 Flange Bolt (6)
    - M8 Flange Nut (4)
4. If you are missing any items from your carton, please call Generac Customer Service at 1-888-436-3722. When calling for assistance, please have the model and serial number from the data tag available.
5. Fill out and send in registration card. Write Model number, Serial number & date of purchase in the table located in the "Where to Find Us" section.

**This page intentionally left blank.**

---

## Section 4 **Set-up**

---

### 4.1 — ASSEMBLY

Read entire operator's manual before you attempt to assemble or if you have any problems with the assembly of your water pump, please call Generac Customer Service at 1-888-436-3722. When calling for assistance, please have the model and serial number from the data tag available.

**If the water pump does not include a wheel kit, skip to "Add Engine Oil".**

You will need the following tools to install the vibration mounts and handle:

- Socket wrench with 12 mm socket (not included)
1. Attach Vibration Mounts (feet) (Figure 4-1).
    - A. Attach the vibration mount to the frame using 2 Flange Bolts (M8x40) and 2 Nuts (M8).
    - B. Slide the bolts through the vibration mount and through the frame.
    - C. Secure with nuts. Tighten, but do not over tighten.
    - D. Repeat A-C for the second vibration mount.

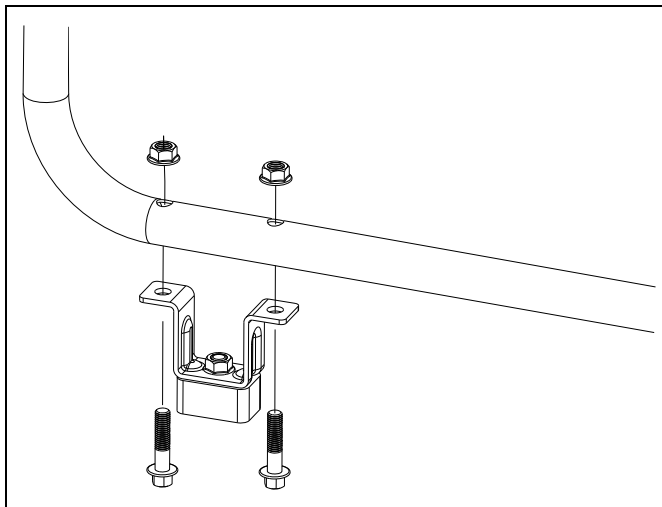

**Figure 4-1. Vibration Mounts**

2. Attach Handle (Figure 4-2).
  - A. Place the handle over the mounting plate of the frame.
  - B. Secure the handle to the frame using 2 Flange Bolts (M8x40).

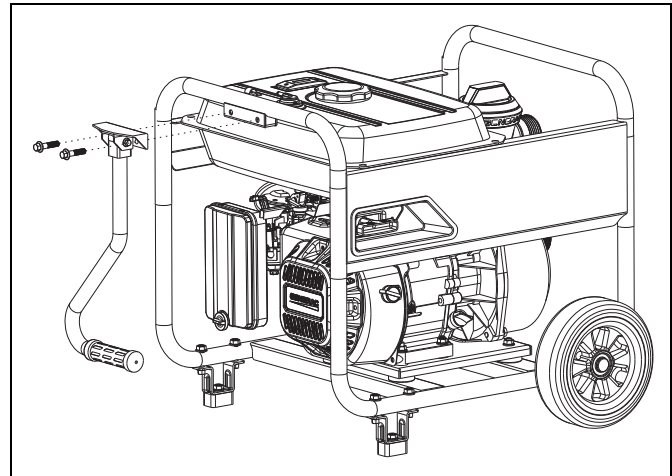

**Figure 4-2. Attach Handle**

3. Attach wheels (Figure 4-3).
  - A. Slide the axle through the wheel, washer, and then the mount point on the frame.
  - B. Insert the cotter pin through the hole in the end of the axle.
  - C. Repeat A-B for the second wheel.

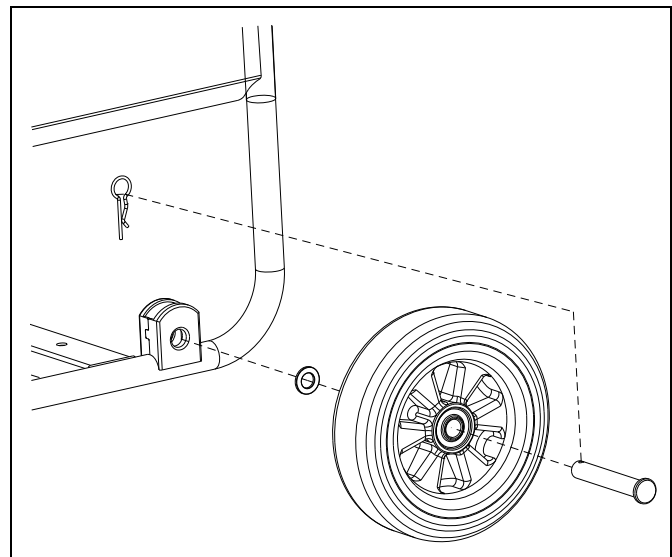

**Figure 4-3. Attach Wheels**

## 4.2 — ADD ENGINE OIL

1. Place water pump on a flat, level surface.
2. Clean area around oil fill and remove ORANGE oil fill cap/dipstick.
3. Using oil funnel, slowly pour oil into fill opening. See “Maintenance” section for oil type recommendation.
4. Check periodically until the oil level is between “L” and “H” on the dipstick (Figure 4-4). Do not overfill.

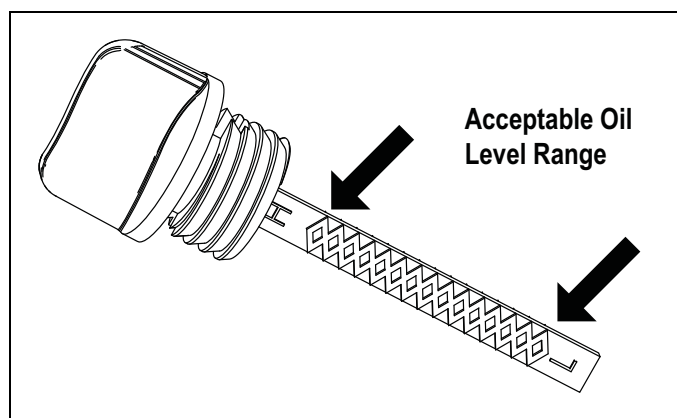

**Figure 4-4. Dipstick**

**NOTE: Any attempt to crank or start the engine before it has been properly serviced with the recommend oil may result in engine failure.**

5. Replace oil fill cap/dipstick and fully tighten.

## 4.3 — FUEL

Fuel must meet these requirements:

- Clean, fresh, unleaded gasoline.
- A minimum of 87 octane/87 AKI (91 RON).
- Gasoline with up to 10% ethanol (gasohol) is acceptable.

**NOTE: Avoid water pump damage. Failure to follow Operator’s Manual for fuel recommendations voids warranty.**

- DO NOT use unapproved gasoline such as E85.
- DO NOT mix oil in gasoline.
- DO NOT modify engine to run on alternate fuels.

To protect the fuel system from gelling, mix in a fuel stabilizer when adding fuel. See Storage. All fuel is not the same. If you experience starting or performance problems after using fuel, switch to a different fuel provider or change brands.

### **⚠ WARNING!**



**Fuel and its vapors are extremely flammable and explosive. Fire or explosion can cause severe burns or death.**

### 4.3.1 — ADDING FUEL

- Turn water pump OFF and let it cool at least two (2) minutes before removing fuel cap. Loosen cap slowly to relieve pressure in tank.
  - Fill fuel tank outdoors.
  - DO NOT overfill tank. Allow space for fuel expansion.
  - If fuel spills, wait until it evaporates before starting engine.
  - Keep fuel away from sparks, open flames, pilot lights, heat, and other ignition sources.
  - DO NOT light a cigarette or smoke.
1. Clean area around fuel fill cap, remove cap.
  2. Slowly add regular unleaded fuel to fuel tank. Be careful not to overfill. Fill to red indicator ring on the fuel filter, this will allow for fuel expansion (Figure 4-5).
  3. Install fuel cap and let any spilled fuel evaporate before starting engine.

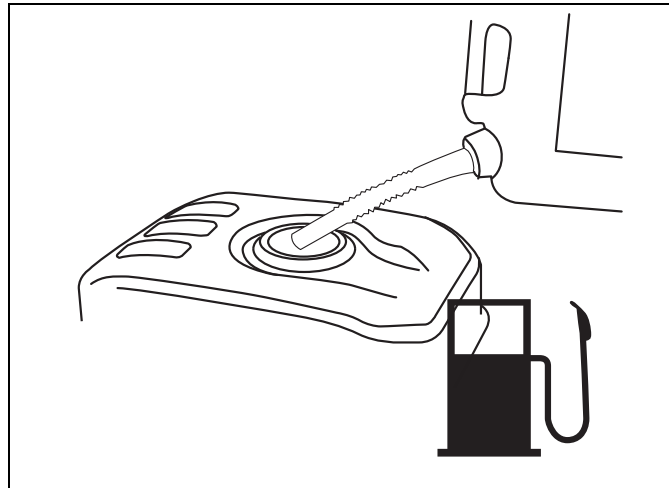
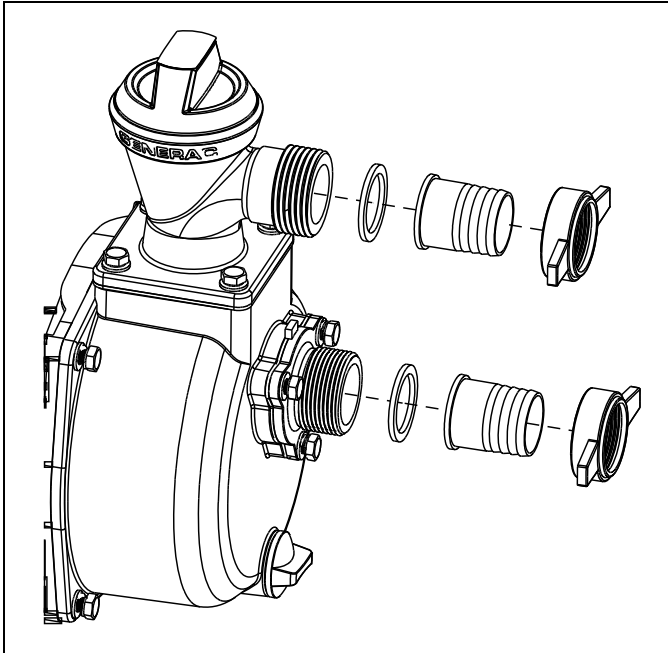

**Figure 4-5. Adding Fuel**



#### 4.4 — CONNECT SUCTION AND DISCHARGE HOSE

1. Attach and thread a gasket and hose barb to each of the threaded flanges using a hose nut (Figure 4-6).



**Figure 4-6. Attach Gasket and Hose Barb**

2. Attach the flexible blue discharge hose to the blue colored flange by sliding the hose over the barb and securing with a hose clamp.
3. Attach the green suction hose to the green colored flange by sliding the hose over the barb and securing with a hose clamp (Figure 4-7).

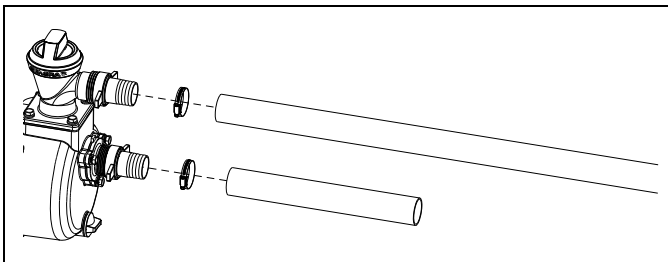

**Figure 4-7. Attach Hoses**

4. Attach the filter to the suction hose by inserting the barb end into the suction hose and securing with a hose clamp. Then attach the filter end (Figure 4-8).

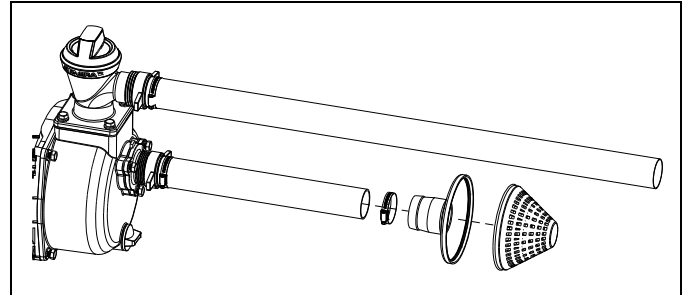

**Figure 4-8. Attach Filter**

#### 4.5 — PRIME THE UNIT

Remove the Easy Prime cap from the pump and completely fill the pump chamber with clean water. Tighten the cap. **DO NOT** over tighten.

**This page intentionally left blank.**

## Section 5 Operation

### 5.1 — OPERATION

If you have any problems operating your water pump, please call Generac customer service at 1-888-436-3722.

### 5.2 — WATER PUMP LOCATION

#### 5.2.1 — Clearances and Air Movement

#### **⚠ DANGER!**



Running engine gives off carbon monoxide, an odorless, colorless, poisonous gas. Breathing carbon monoxide can cause headache, fatigue, dizziness, vomiting, confusion, seizures, nausea, fainting or death. For more information, reference the CO warnings in the “Safety” section.

Place water pump outdoors in an area that will not accumulate deadly exhaust gas. NEVER place water pump where exhaust gas could accumulate and enter inside or be drawn into a potentially occupied building. Ensure exhaust gas is kept away from any windows, doors, ventilation intakes, or other openings that can allow exhaust gas to collect in a confined area. Prevailing winds and air currents should be taken into consideration when positioning water pump (Figure 5-1).

- Operate water pump ONLY outdoors.
- Keep exhaust gas from entering a confined area through windows, doors, ventilation intakes, or other openings.
- NEVER start or run engine indoors, in a vehicle or in an enclosed area, EVEN if windows and doors are open.

#### **⚠ WARNING!**



Exhaust heat/gases can ignite combustibles, structures or damage fuel tank causing a fire.

- Keep at least 5 ft. (152 cm) clearance on all sides of water pump including overhead.

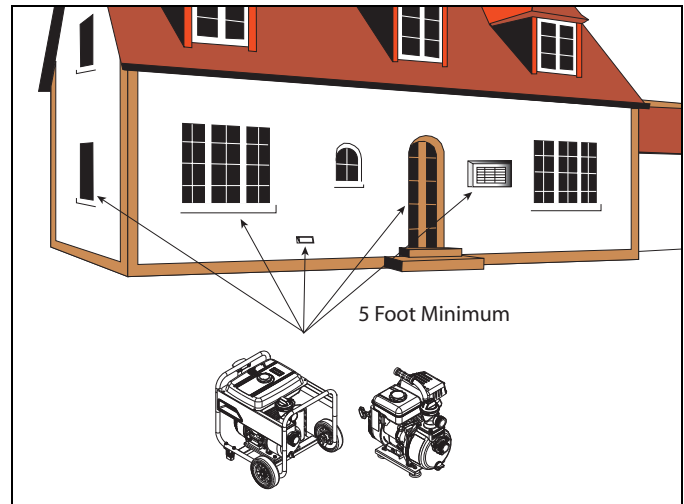

**Figure 5-1. Building Clearances**

Place the pump on a level surface free from any obstructions or potential hazards. The pump should be placed close to the water level to ensure maximum performance.

Pump output will be affected by the type, length, and size of the suction and discharge hoses. The pumping height, total head, is the distance from the water level to the point of discharge (Figure 5-2). As this distance increases, the pump output decreases. The discharge capacity is greater than the suction capacity, therefore it is important to keep the suction head less than the discharge head. The time required to draw water from the source to the pump (self-priming time) can be decreased by minimizing the suction head.

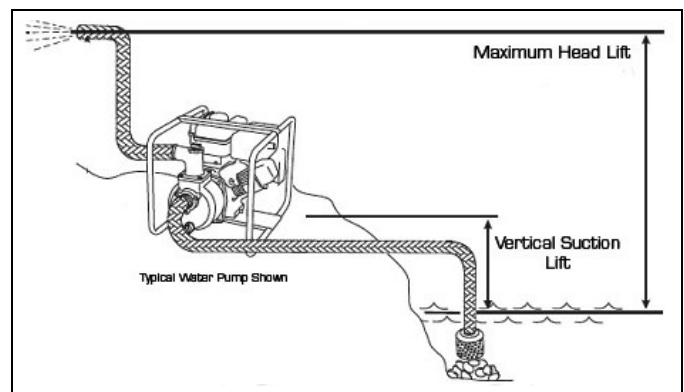

**Figure 5-2. Pump Output**

Route the suction hose so that the filter is immersed completely in the water supply source. DO NOT operate pump without the filter fully immersed. DO NOT operate the pump without the filter attached to the hose. Secure the suction hose to keep it from moving once the Water Pump is turned on.

Route the discharge hose to the desired location. Secure the discharge hose to keep it from moving once the Water Pump is turned on.

### 5.3 — CHECKLIST BEFORE STARTING ENGINE

1. Be sure to read and understand the “Safety” section and “Operation” section before using water pump.
2. Check that the oil is at the full mark on the dipstick, and that fuel has been added to the fuel tank.
3. Review the unit’s assembly and ensure fitting are properly secured and make sure there are no kinks, cuts, or damage to hoses.
4. Confirm unit is secure on level ground and surrounding work area is clear.

**NOTE:** For the ST20K model, pumping water with solids larger than .25" can damage the pump and void the warranty.

### 5.4 — HOW TO START YOUR WATER PUMP

**NOTE:** DO NOT run the pump without the unit primed and suction hose in the water. Damage to equipment resulting from failure to follow this instruction will void warranty.

#### 5.4.1 — Starting the CW15 Water Pump

1. Flip engine switch (A) to the ON position (Figure 5-3).
2. Move choke lever (B) to CHOKE position.
  - A. For a warm engine, be sure the choke lever is in the RUN position.
3. Secure unit from movement when pulling starter handle (C).

#### **▲ WARNING!**

 **Starter cord kickback (rapid retraction) can result in bodily injury. Broken bones, fractures, bruises, or sprains could result.**

4. When starting the engine, grasp starter grip handle and pull slowly until you feel some resistance. Then pull rapidly to start engine.
5. Return starter grip handle slowly. DO NOT let rope “snap back” against starter.

6. When engine starts, slowly move choke lever to RUN position as engine warms. If engine falters, move choke lever to CHOKE position, then back to RUN position.
7. If engine fails to start after five (5) pulls, move choke lever to RUN position, and repeat steps 4 through 7.

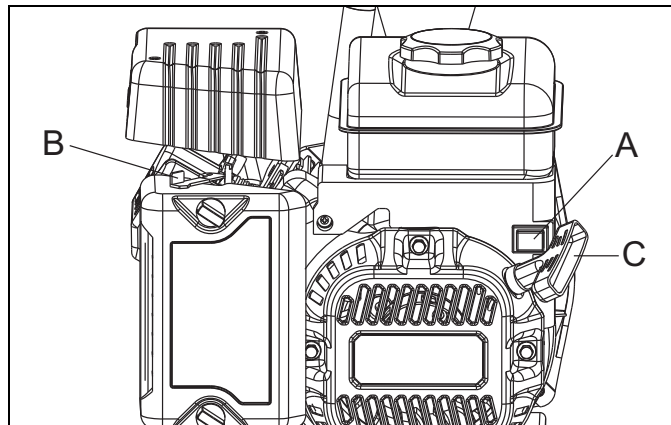

**Figure 5-3. Start the CW15 Water Pump**

#### 5.4.2 — Starting the ST20 Water Pump

1. Move fuel valve lever (A) to ON position (Figure 5-4).
2. Move choke lever (B) to CHOKE position.
  - A. For a warm engine, be sure the choke lever is in the RUN position.

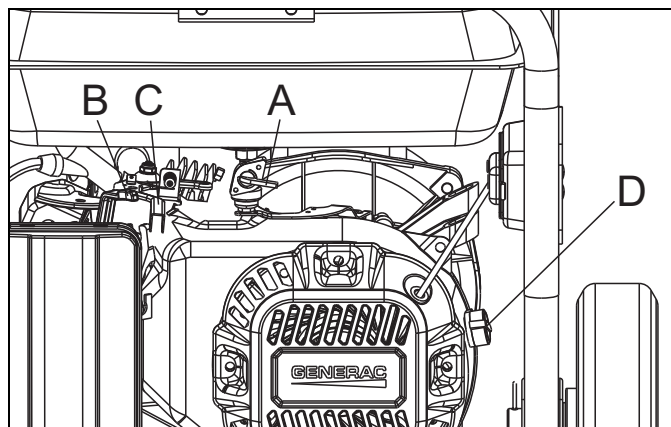

**Figure 5-4. Start the ST20 Water Pump**

3. Move throttle control lever (C) to “High” (Rabbit) position (Figure 5-6).
4. Turn the engine switch (D) to ON position (Figure 5-5).
5. Secure unit from movement when pulling starter handle (E) (Figure 5-5).

**⚠ WARNING!**



**Starter cord kickback (rapid retraction) can result in bodily injury. Broken bones, fractures, bruises, or sprains could result.**

6. When starting engine, grasp starter grip handle and pull slowly until you feel some resistance. Then pull rapidly to start engine.
7. Return starter grip handle slowly. DO NOT let rope “snap back” against starter.
8. When engine starts, slowly move choke lever to RUN position as engine warms. If engine falters, move choke lever to CHOKE position, then back to RUN position.
9. If engine fails to start after 5 pulls, move choke lever to RUN position, and repeat steps 6 through 9.

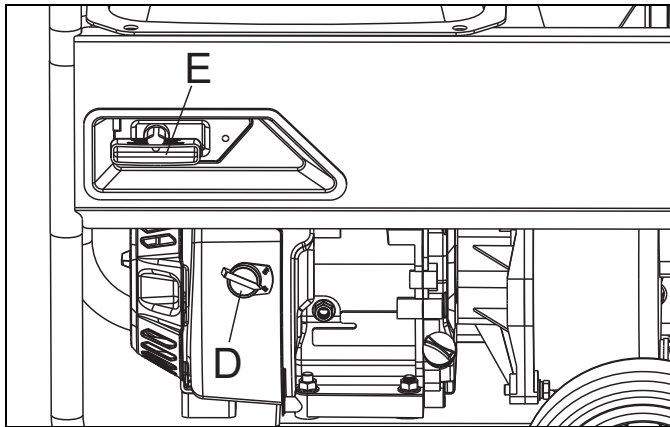

**Figure 5-5. Start the ST20 Water Pump**

**NOTE:** It is normal for the Water Pump to fluctuate speed while the system is self priming due to air pockets in the suction hose.

**⚠ WARNING!**



**Contact with muffler area can result in serious burns. Exhaust heat/gases can ignite combustibles, structures or damage fuel tank causing a fire.**

- DO NOT touch hot parts and AVOID hot exhaust gases.
- Allow equipment to cool before touching.
- Keep at least 5 feet (152 cm) of clearance on all sides of water pump including overhead.
- It is a violation of California Public Resource Code, Section 4442, to use or operate the engine on any forest-covered, brush-covered, or grass-covered land unless the exhaust system is equipped with a spark arrester, as defined in Section 4442, maintained in effective working order. Other states or federal jurisdictions may have similar laws.

- Replacement parts must be the same and installed in the same position as the original parts.

**5.5 — HOW TO STOP YOUR WATER PUMP**

1. Move throttle control lever on engine to “Low” (Turtle) position (Figure 5-6) (if applicable).
2. Turn the engine ON/OFF switch to the OFF (0) position.
3. Turn the fuel valve to the OFF (0) position (if applicable).
4. Allow the engine to cool thoroughly.
5. After cooling, remove the priming plug and drain plug from the pump casing and allow it to drain completely.

**⚠ WARNING!**



**Never operate a damaged or defective pump. To prevent accidental starting, remove and ground the spark plug wire before performing any service.**

**NOTE:** The owner/operator is responsible for all periodic maintenance. Complete all scheduled maintenance in a timely manner. Correct any issues before operating the pump. Improper maintenance will void the pump's warranty.

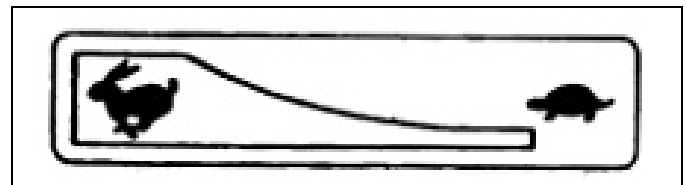

**Figure 5-6. Throttle Position**

**This page intentionally left blank.**

---

## Section 6 *Maintenance*

---

### 6.1 — MAINTENANCE RECOMMENDATIONS

Regular maintenance will improve the performance and extend the life of the water pump. See any qualified dealer for service.

The water pump's warranty does not cover items that have been subjected to operator abuse or negligence. To receive full value from the warranty, the operator must maintain the water pump as instructed in this manual, including proper storage as detailed in and "Long Term Storage".

**NOTE: Should you have questions about replacing components on your water pump, please call 1-888-436-3722 for assistance.**

Some adjustments will need to be made periodically to properly maintain your water pump.

All service and adjustments should be made at least once each season. Follow the requirements in the "Maintenance Schedule" chart.

**NOTE: Once a year you should clean or replace the spark plug, clean or replace the air filter, and check the hoses for wear. A new spark plug and clean air filter assure proper fuel-air mixture and help your engine run better and last longer.**

### 6.2 — MAINTENANCE SCHEDULE

Follow the hourly or calendar intervals, whichever occurs first. More frequent service is required when operating in adverse conditions.

<b>First 5 Hours</b>
Change engine oil
<b>Every 8 Hours or Daily</b>
Check/clean air filter and suction hose filter*
Check hoses
Check hose connections for leaks
Clean debris off water pump
Check engine oil level
<b>Every 20 Hours or Every Season</b>
Change engine oil**
<b>Every 50 Hours or Every Season</b>
Check/clean air cleaner filter**
Inspect muffler and spark arrester*
<b>Every 100 Hours or Every Season</b>
Service spark plug
* Clean if clogged. Replace if broken. ** Service more often under dirty or dusty conditions.

### 6.3 — EMISSIONS CONTROL

**Maintenance, replacement, or repair of the emissions control devices and systems may be performed by any non-road engine repair establishment or individual.** However, to obtain "no charge" emissions control service, the work must be performed by a factory authorized dealer. See the Emissions Warranty.

## 6.4 — WATER PUMP MAINTENANCE

### 6.4.1 — Clean Debris

Daily or before use, clean accumulated debris from water pump. Keep linkage, spring and controls clean. Keep area around and behind muffler free from any combustible debris. Inspect cooling air slots and openings on the water pump. These openings must be kept clean and unobstructed.

Water pump parts should be kept clean to reduce the risk of overheating and ignition of accumulated debris.

- Use a damp cloth to wipe exterior surfaces clean.

**NOTE: Improper treatment of water pump can damage it and shorten its life.**

- DO NOT insert any objects through cooling slots.
- Use a soft bristle brush to loosen caked on dirt, oil, etc.
- Use a vacuum cleaner to pick up loose dirt and debris.

## 6.5 — CHECK HOSE FILTER

Examine the filter on the suction hose. Clean it if the slots are clogged or replace it if filter is damaged.

## 6.6 — CHECK HOSES

The hoses can develop leaks from wear, kinking, or abuse. Inspect the hoses each time before using them. Check for cuts, leaks, abrasions or bulging, damage or movement of couplings. If any of these conditions exist, replace the hose.

## 6.7 — ENGINE MAINTENANCE

### ⚠ WARNING!



Unintentional sparking can result in fire or electric shock.

### WHEN ADJUSTING OR MAKING REPAIRS TO YOUR WATER PUMP

- Disconnect the spark plug wire from the spark plug and place the wire where it cannot contact spark plug.

### WHEN TESTING FOR ENGINE SPARK

- Use approved spark plug tester.
- DO NOT check for spark with spark plug removed.

## 6.8 — ENGINE OIL RECOMMENDATIONS

We recommend the use of high-quality detergent oils acceptable if classified for service SF, SG, SH, SJ or higher. DO NOT use special additives.

Outdoor temperatures determine the proper oil viscosity for the engine. Use the chart to select the best viscosity for the outdoor temperature range expected.

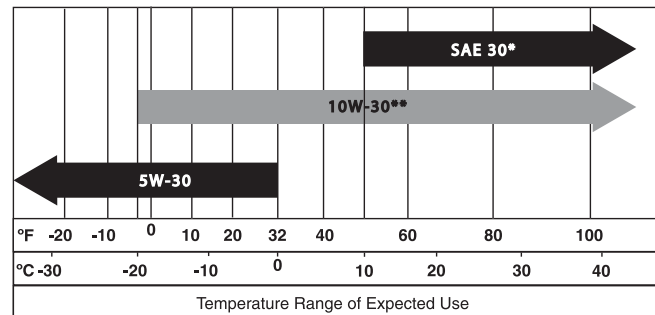

\* Below 50 °F (10 °C) the use of SAE 30 will result in hard starting.

\*\* Above 80 °F (27 °C) the use of 10W30 may cause increased oil consumption. Check oil level more frequently.

**NOTE: The ST20K engine is equipped with an "Oil Alert System". This system will automatically stop the engine before the oil level falls below a safe limit. To avoid the inconvenience of an unexpected shut-down, always check the engine oil level before startup.**

### 6.8.1 — Check Oil Level

Oil level should be checked prior to each use or at least every 8 hours of operation. Keep oil level maintained.

1. Make sure water pump is on a flat, level surface.
2. Clean area around oil fill and wipe dipstick clean remove oil fill cap (Figure 6-1).
3. Verify oil is at the proper level on the dipstick.
4. Replace and tighten oil fill cap.

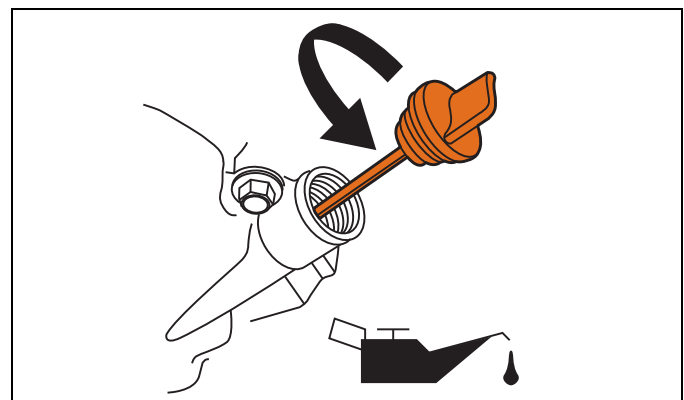

Figure 6-1. Fill Engine Oil



### 6.8.2 — Adding Engine Oil

1. Make sure water pump is on a flat, level surface.
2. Check oil level as described in Checking Oil Level.
3. If needed, slowly pour oil into oil fill opening until the proper level on the dipstick is reached.
4. Insert the dipstick into filler neck but do not screw it in.
5. If level is low, fill until the oil level is between “L” and “H” on the dipstick (Figure 6-2).
6. Replace and tighten oil fill cap.

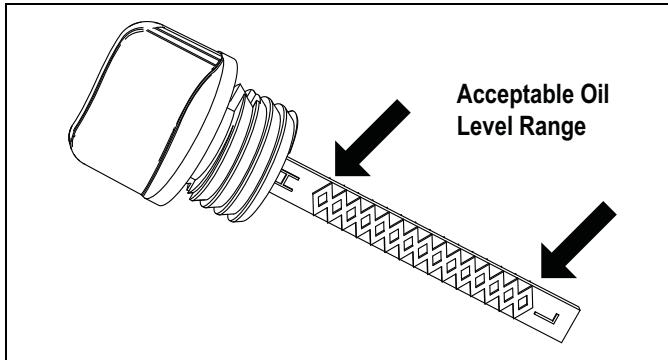

Figure 6-2. Dipstick

5. Remove oil drain plug and drain oil completely into a suitable container.
6. Reinstall oil drain plug and tighten securely.
7. Slowly pour oil into oil fill opening to the proper level on the dipstick. DO NOT overfill.
8. Reinstall oil fill cap. Finger tighten cap securely.
9. Wipe up any spilled oil.
10. Properly dispose of oil in an accordance with all local regulations.

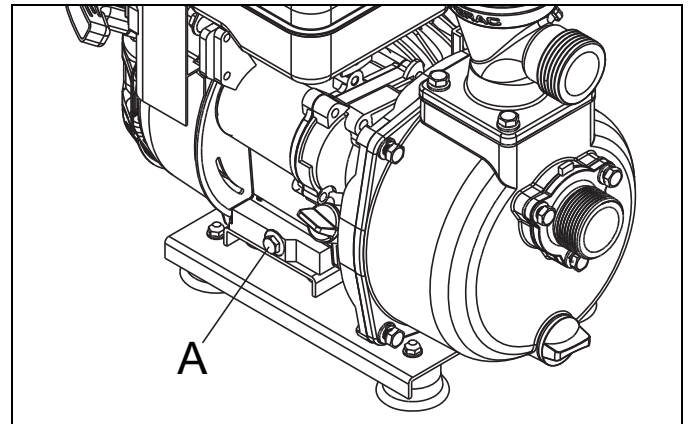

Figure 6-3. CW15 Oil Drain Plug

### 6.8.3 — Changing Engine Oil

If you are using your water pump under extremely dirty or dusty conditions, or in extremely hot weather, change the oil more often.

#### ⚠ CAUTION!



**Avoid prolonged or repeated skin contact with used motor oil.**

- Used motor oil has been shown to cause skin cancer in certain laboratory animals.
- Thoroughly wash exposed areas with soap and water.



**KEEP OUT OF REACH OF CHILDREN.**

- Don't pollute. Conserve resources. Return used oil to collection centers.

Allow the engine to cool down and then change oil as follows:

1. Make sure water pump is on a flat, level surface.
2. Disconnect the spark plug wire from the spark plug and place the wire where it cannot contact spark plug.
3. Clean area around oil drain plug (A) (Figure 6-3) and (Figure 6-4). The oil drain plug is located at base of engine.
4. Remove oil fill cap (Figure 6-1).

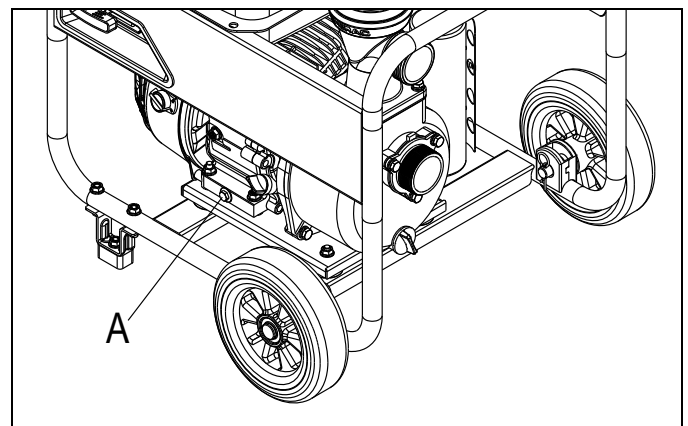

Figure 6-4. ST20 Oil Drain Plug

### 6.9 — SERVICE AIR CLEANER

Your engine will not run properly and may be damaged if you run it with a dirty air cleaner. Service more often if operating under dirty or dusty conditions.

To service the air cleaner, follow these steps:

1. Remove air cleaner screw(s), and pull off the air cleaner cover (Figure 6-5) and (Figure 6-6).
2. Remove old foam filter and replace with a clean new foam filter.
3. Install cover and insert air cleaner screw(s).

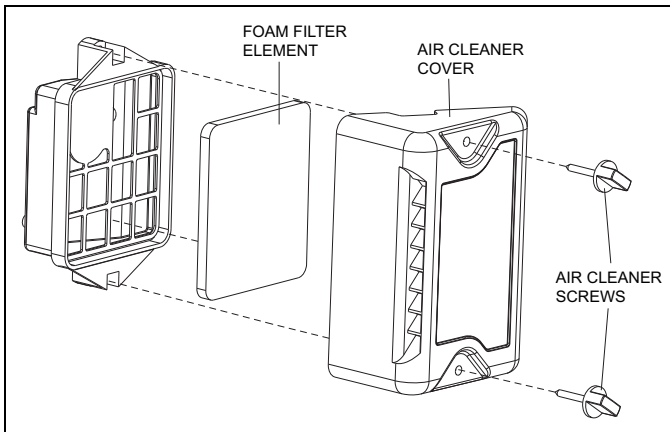

**Figure 6-5. Service the CW15 Air Cleaner**

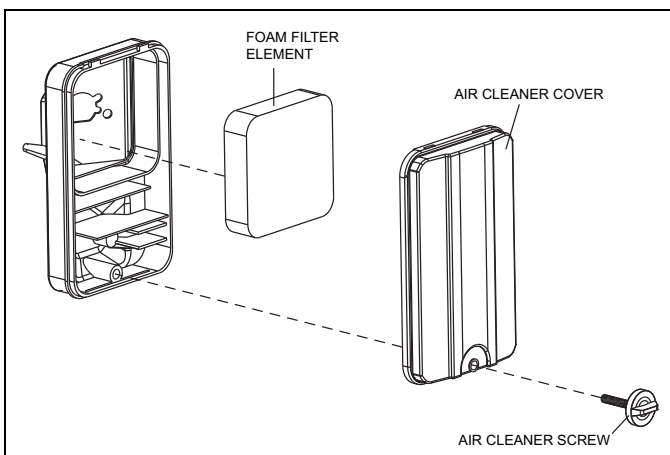
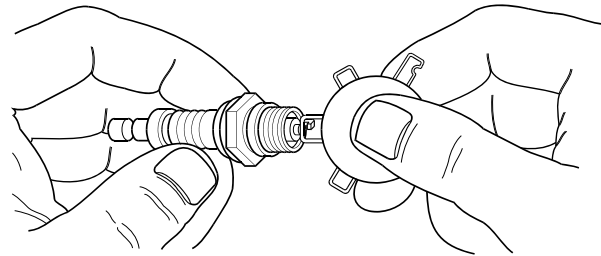

**Figure 6-6. Service the ST20 Air Cleaner**

## 6.10 — SERVICE SPARK PLUG

Changing the spark plug will help your engine to start easier and run better.

1. Clean area around spark plug.
2. Remove and inspect spark plug.
3. Check electrode gap with wire feeler gauge and reset spark plug gap to recommended gap if necessary (see Specifications) (Figure 6-7).
4. Replace spark plug if electrodes are pitted, burned or porcelain is cracked. Use the recommended replacement plug. See Specifications.
5. Install spark plug and tighten firmly.



**Figure 6-7. Spark Plug Gap**

## 6.11 — AFTER EACH USE

Water should not remain in the unit for long periods of time. Sediments or minerals can deposit on pump parts and freeze pump action. Follow these procedures after every use:

1. Shut off engine.
2. Disconnect hoses. Drain water from hose. Use a rag to wipe off the hose.
3. Empty pump of all liquids. Remove drain cap, let drain completely, replace drain cap.
4. Store unit in a clean, dry area.
5. If storing for more than 30 days, see the "Long Term Storage".

### **⚠ WARNING!**



**Fuel and its vapors are extremely flammable and explosive. Fire or explosion can cause severe burns or death.**

## WHEN STORING FUEL OR EQUIPMENT WITH FUEL IN TANK

- Store away from furnaces, stoves, water heaters, clothes dryers, or other appliances that have pilot light or other ignition source because they can ignite fuel vapors.

## 6.12 — LONG TERM STORAGE

If you do not plan to use the water pump for more than 30 days, you must prepare the engine and pump for long term storage.

### 6.12.1 — Protect Fuel System

Fuel can become stale when stored over 30 days. Stale fuel causes acid and gum deposits to form in the fuel system or on essential carburetor parts. To keep fuel fresh, use a fuel stabilizer, available as a liquid additive or a drip concentrate cartridge.

There is no need to drain gasoline from the engine if a fuel stabilizer is added according to instructions. Run the engine for 2 minutes to circulate the stabilizer throughout the fuel system. The engine and fuel can then be stored up to 24 months.

If gasoline in the engine has not been treated with a fuel stabilizer, it must be drained into an approved container. Run the engine until it stops from lack of fuel. The use of a fuel stabilizer in the storage container is recommended to maintain freshness.

**⚠ WARNING!**



**Hearing Protection Recommended.**

**6.12.2 — Protect Engine**

1. Change engine oil.
2. Remove spark plug.
3. Pour a tablespoon (5-10 cc) of clean engine oil into the cylinder.
4. Pull the starter rope several times to distribute the oil in the cylinder.
5. Reinstall the spark plug.
6. Pull the starter rope slowly until resistance is felt. This will close the valves so moisture cannot enter the engine cylinder. Return the starter rope gently.

**6.12.3 — Change Oil**

Allow the engine to cool down and then drain oil from crankcase. Refill with recommended grade. See “Changing Engine Oil”.

**⚠ CAUTION!**



**Hot oil may cause burns. Allow engine to cool before draining oil. Avoid prolonged or repeated skin exposure with used oil. Thoroughly wash exposed areas with soap.**

**6.12.4 — Protecting the Pump**

To protect the pump from damage caused by mineral deposits or freezing. Make sure the pump is completely drained of all water. Spray WD-40, or similar product, into all ports and drainage hole.

- Failure to do so will permanently damage your pump and render your unit inoperable.
- Freeze damage is not covered under warranty.

**6.13 — OTHER STORAGE INSTRUCTIONS**

1. DO NOT store fuel from one season to another unless it has been treated as described in Protect Fuel System.
2. Replace fuel container if it starts to rust. Rust and/or dirt in fuel can cause problems if it’s used with this unit.
3. Cover unit with a suitable protective cover that does not retain moisture.

**⚠ WARNING!**



**Storage covers can be flammable.**

- DO NOT place a storage cover over a hot water pump.
- Let equipment cool for a sufficient time before placing the cover on the equipment.
- 4. Store unit in a clean and dry area.

**6.14 — TRANSPORTING/TIPPING OF THE UNIT**

Do not operate, store or transport the unit at an angle greater than 15 degrees.

**This page intentionally left blank.**

# Section 7 *Troubleshooting*

## 7.1 — TROUBLESHOOTING GUIDE

PROBLEM	CAUSE	CORRECTION
Pump will not pump.	<ol style="list-style-type: none"> <li>Air leak in suction hose.</li> <li>The suction and/or discharge line(s) may be blocked.</li> <li>The end of the suction line is not submerged.</li> <li>Total head is too high for this pump to work against</li> </ol>	<ol style="list-style-type: none"> <li>Make sure suction hose is double clamped at joints, clamps are tight, fittings have thread compound and are tight, with no nicks or cuts in hose.</li> <li>Check to see that the hoses and filter are in good working order.</li> <li>Increase its length, or move pump closer to source of liquid.</li> <li>Reduce total head or use a higher head pump.</li> </ol>
Pump will not prime.	<ol style="list-style-type: none"> <li>Excessive suction lift (*1).</li> </ol>	<ol style="list-style-type: none"> <li>Move the pump closer to liquid source.</li> </ol>
Priming takes a long time.	<ol style="list-style-type: none"> <li>Suction line is quite long.</li> <li>Air pockets or leaks in the suction line.</li> </ol>	<ol style="list-style-type: none"> <li>Move pump closer to source.</li> <li>Check the line for loose connections. Make sure suction hose is submerged.</li> </ol>
Pump does not perform as well as it should.	<ol style="list-style-type: none"> <li>Flow is restricted due to debris build-up.</li> <li>Insufficient submergence of the end of suction hose.</li> <li>Excessively worn impeller (*2).</li> <li>Seal is damaged (*3). Liquid will be leaking through the middle of the adapter.</li> <li>Air pockets or leaks in the suction hose.</li> <li>Clogged impeller.</li> <li>Engine throttle is in SLOW position.</li> </ol>	<ol style="list-style-type: none"> <li>Clean the hoses, fittings and filter.</li> <li>The end of the suction line must be submerged.</li> <li>Replace impeller.</li> <li>Replace the seal.</li> <li>Check suction hose.</li> <li>Remove casing to clean out.</li> <li>Move throttle to FAST position.</li> </ol>
Pump loses prime.	<ol style="list-style-type: none"> <li>Water level drops below the end of the suction line.</li> </ol>	<ol style="list-style-type: none"> <li>Increase length of suction line or move the pump closer to the water source.</li> </ol>
Pump will not start.	<ol style="list-style-type: none"> <li>No fuel.</li> <li>Faulty spark plug.</li> <li>Fuel valve lever is in the OFF position.</li> <li>Ignition switch is in the OFF position.</li> <li>Choke is in the wrong position.</li> </ol>	<ol style="list-style-type: none"> <li>Allow engine to cool for 2 minutes, then fill fuel tank.</li> <li>Replace spark plug.</li> <li>Turn the fuel valve lever to the ON position.</li> <li>Turn the ignition switch to the ON position.</li> <li>Slide choke lever to the CHOKE position.</li> </ol>
Pump starts, but runs roughly.	<ol style="list-style-type: none"> <li>Choke is in the wrong position.</li> <li>Spark plug wire is loose.</li> <li>Faulty spark plug.</li> <li>Fuel is contaminated (water, debris, etc.).</li> </ol>	<ol style="list-style-type: none"> <li>Slide choke lever to the RUN position.</li> <li>Attach wire to spark plug securely.</li> <li>Replace spark plug.</li> <li>Allow engine to cool for 2 minutes, then drain fuel tank and carburetor. Fill tank with fresh fuel.</li> </ol>
Pump shuts down during operation.	<ol style="list-style-type: none"> <li>No fuel.</li> <li>Low oil sensor shuts down unit.</li> </ol>	<ol style="list-style-type: none"> <li>Allow engine to cool for 2 minutes, then fill fuel tank.</li> <li>Make sure unit is on flat surface. Check oil level and add more if necessary.</li> </ol>

1. Excessive suction lift must take into consideration:

- Size and length of pipe
- Pipe fitting
- Elevation above sea level

Including all of the above, we recommend that the total suction head not exceed 26 ft.

2. An excessively worn impeller is mainly caused from cavitation, which is caused by a number of situations, such as:

- Restricted suction
- Excessive suction lift

3. The seal may be damaged due to:

- Normal wear
- Overheating
- Pumping chemicals that this seal is not designed for.

Contact an authorized service depot for further assistance.

**This page intentionally left blank.**



Part No. 0K9077 Rev A 10/02/14  
© Generac Power Systems, Inc. All rights reserved  
Specifications are subject to change without notice.  
No reproduction allowed in any form without prior written  
consent from Generac Power Systems, Inc.

Generac Power Systems, Inc.  
S45 W29290 Hwy. 59  
Waukesha, WI 53189  
1-888-GENERAC (1-888-436-3722)  
[generac.com](http://generac.com)