



MILL DRILL AND STAND

Read carefully and follow all safety rules and operating instructions before first use of this product.

DESCRIPTION

Palmgren 12-Speed Mill Drill Model 80161 is a ruggedly constructed machine providing accurate milling, drilling and boring capabilities. The fully enclosed R-8 spindle has heavy-duty tapered thrust bearings at top and bottom of quill, adjustable depth of stop with scale, fine feed adjustment handwheel with .001" graduations and quill lock down handle for securely clamping spindle at desired depth. One piece cast iron head rotates 360° and travels vertically by rack and pinion.

Hinged pulley cover allows fast and easy speed changes. Large 31⁷/₈ x 9³/₈" table has dovetail ways with adjustable gibs and bronze lead screw nuts for accurate and rigid table positioning. Table has four ⁵/₈" T-slots, zero setting handwheel dials with .001" graduations, adjustable stops for longitudinal feed and cross feed way cover.

A 1¹/₂ HP, 1725 RPM, 115/230 volt single-phase motor is included. Palmgren Mill Drill Stand Model 70104 is a heavy-duty stand for mounting the Palmgren mill drill and many other mill drills. Stand is 14 gauge steel providing strength and rigidity. Stand features mounting flanges for mounting stand to floor, large chip pan, mounting bolts and leveling pads.

UNPACKING

Refer to Figure 1.

Check for shipping damage. If damage has occurred, a claim must be filed with carrier immediately. Check for completeness. Immediately report missing parts to dealer.

Carefully open crate and remove loose parts box. Unbolt mill drill from shipping pallet and remove from crate using heavy duty lifting equipment such as an overhead crane.

WARNING: Be careful not to touch overhead power lines, piping, lighting, etc. if lifting equipment is used. Mill Drill weighs approximately 650 lbs. Proper tools, equipment and qualified personnel should be employed in all phases of unpacking and installation. Mill drill is shipped assembled except for certain parts shipped loose in a wooden box. Locate and account for the following parts:

- A Drill chuck arbor
- B 5/8" Drill chuck with key
- C Face mill arbor
- D 3" Face milling cutter
- E Two Table handwheels
- F R8/3MT Adapter
- G Drawbar

Optional stand is shipped unassembled.

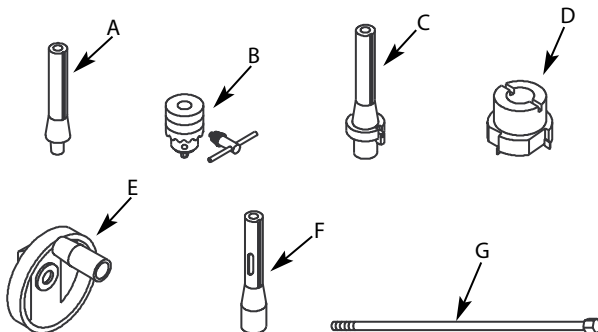

Figure 1 – Unpacking

IMPORTANT: Table is coated with a protectant. To ensure proper fit and operation, remove coating. Coating is easily removed with mild solvents, such as mineral spirits, and a soft cloth. Avoid getting cleaning solution on paint or any of the rubber or plastic parts. Solvents may deteriorate these finishes. Use soap and water on paint, plastic or rubber components. After cleaning, cover all exposed surfaces with a light coating of oil. Paste wax is recommended for table tops.

WARNING: Never use highly volatile solvents. Non-flammable solvents are recommended to avoid possible fire hazard.

SPECIFICATIONS

Model 80161

Horsepower	1 ¹ / ₂ HP
12 Speeds	120, 190, 230, 285, 370, 440, 770, 1040, 1220, 1450, 1800, 2500 RPM
Table size	31 ⁷ / ₈ x 9 ³ / ₈ "
T-slots	⁵ / ₈ " slots, four
Swing	16"
Spindle taper	R-8 with ⁷ / ₁₆ "-20 drawbar
Drilling capacity	1 ¹ / ₄ " mild steel 1 ¹ / ₂ " cast iron
End mill capacity	³ / ₄ " mild steel
Face mill capacity	3" mild steel
Spindle stroke	5"
Max. distance spindle to table	17 ³ / ₄ "
Head swivel	360°
Quill diameter	3"
Column diameter	4 ¹ / ₂ "
Left-right table travel (longitudinal)23"
Front-back table travel (cross)7"
Motor	1 ¹ / ₂ HP, 1725 RPM, 115/230 volt, single-phase

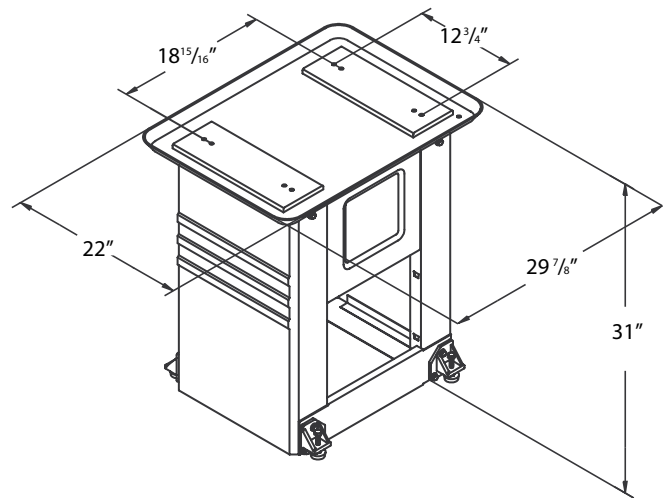

Figure 2 – Dimensions for 70104

SAFETY RULES

WARNING: For your own safety, read all of the instructions and precautions before operating tool.

CAUTION: Always follow proper operating procedures as defined in this manual even if you are familiar with use of this or similar tools. Remember that being careless for even a fraction of a second can result in severe personal injury.

SAFETY RULES (CONTINUED)**BE PREPARED FOR JOB**

- Wear proper apparel. Do not wear loose clothing, gloves, neckties, rings, bracelets or other jewelry which may get caught in moving parts of machine.
- Wear protective hair covering to contain long hair.
- Wear safety shoes with non-slip soles.
- Wear safety glasses complying with United States ANSI Z87.1. Everyday glasses have only impact resistant lenses. They are NOT safety glasses.
- Wear face mask or dust mask if operation is dusty.
- Be alert and think clearly. Never operate power tools when tired, intoxicated or when taking medications that cause drowsiness.

PREPARE WORK AREA FOR JOB

- Keep work area clean. Cluttered work areas invite accidents.
- Do not use power tools in dangerous environments. Do not use power tools in damp or wet locations. Do not expose power tools to rain.
- Work area should be properly lighted.
- Proper electrical receptacle should be available for tool. Three-prong plug should be plugged directly into properly grounded, three-prong receptacle.
- Extension cords should have a grounding prong and the three wires of the extension cord should be of the correct gauge.
- Keep visitors at a safe distance from work area.
- Keep children out of workplace. Make workshop childproof. Use padlocks or master switches to prevent any unintentional use of power tools.

TOOL SHOULD BE MAINTAINED

1. Always unplug tool prior to inspection.
2. Consult manual for specific maintaining and adjusting procedures.
3. Keep tool lubricated and clean for safest operation.
4. Remove adjusting tools. Form habit of checking to see that adjusting tools are removed before switching machine on.
5. Keep all parts in working order. Check to determine that the guard or other parts will operate properly and perform their intended function.
6. Check for damaged parts. Check for alignment of moving parts, binding, breakage, and mounting or any other condition that may affect a tool's operation.
7. A guard or other damaged part should be properly repaired or replaced. Do not perform makeshift repairs. (Use parts list provided to order replacement parts.)

KNOW HOW TO USE TOOL

- Use right tool for job. Do not force tool or attachment to do a job for which it was not designed.
- Disconnect tool when changing drill bit or cutter.
- Avoid accidental start-up. Make sure that the tool is in the OFF position before plugging in.
- Do not force a tool. It will work most efficiently at the rate for which it was designed.
- Keep hands away from moving parts and cutting surfaces.

- Never leave tool running unattended. Turn the power off and do not leave tool until it comes to a complete stop.
- Do not overreach. Keep proper footing and balance.
- Never stand on tool. Serious injury could occur if tool is tipped or if drill bit is unintentionally contacted.
- Know your tool. Learn the tool's operation, application and specific limitations.
- Use recommended accessories (refer to page 13). Use of improper accessories may cause risk of injury to persons.
- Handle workpiece correctly. Protect hands from possible injury.
- Turn machine off if it jams. Drill bit or cutter jams when it digs too deeply into workpiece. (Motor force keeps it stuck in the work.)
- Clamp workpiece or brace against column to prevent rotation.
- Feed work into a bit or cutter against the direction of rotation of bit or cutter.
- Use recommended speed for mill drill accessory and workpiece material.

CAUTION: Think safety! Safety is a combination of operator common sense and alertness at all times when tool is being used.

ASSEMBLY

Refer to Figures 3, 6, 7, 8 and 10.

CAUTION: Do not attempt assembly if parts are missing. Use this manual to order replacement parts.

MILL DRILL INSTALLATION

Mill drill must be mounted to a flat level surface. Use shims or machine mounts if necessary. Do not mount machine in direct sunlight. Heat caused by sunlight may deform plastic parts on machine.

If stand is used, be sure to bolt mill drill to stand and level stand to floor to minimize vibration. Use hex head bolts, hex nuts and leveling pads (Figure 10, Ref. Nos. 8, 11 and 12) to align the mill drill. Tighten all nuts and bolts that may have loosened in shipping. Secure mill drill base to stand or bench.

ASSEMBLE STAND (OPTIONAL)

Refer to Figure 10.

- Place both supports (Ref. No. 5) upside down on floor.
- Attach feet (Ref. No. 9) and plate (Ref. No. 7) to each support using hex head bolts, washers and hex nuts (Ref. No. 2, 3 and 4). Finger tighten fasteners at this time.
- Repeat on other side of supports with feet and plate (Ref. No. 14).
- Turn unit right side up.
- Install left and right panels (Ref. Nos. 6 and 13). Gently spread supports so that tabs on panels fit into slots located on supports.
- Secure all fasteners from steps 2 and 3.
- Place chip pan (Ref. No. 1) on top of supports, locating the bottom rail of the chip pan inside the supports.
- Secure chip pan to supports using hex head bolts and flat washers (Ref. Nos. 2 and 3).

MOUNT MILL DRILL TO STAND

Refer to Figure 10.

Place mill drill on stand with mounting holes aligned. Bolt mill drill base to stand with four hex head bolts and four flat washers (Ref. Nos. 3 and 10).

ASSEMBLY (CONTINUED)

MOUNT TABLE HANDWHEELS

Refer to Figure 8.

Thread table handles (Ref. No. 11) into table handwheels (Ref. No. 12). Secure handwheels to left and right ends of longitudinal lead screw (Ref. No. 35) using set screws (Ref. No. 30).

INSTALL DRAWBAR AND ARBOR

Refer to Figures 6 and 7.

Insert draw bar (Figure 7, Ref. No. 52) into top of spindle. Be sure that arbor and spindle taper are clean of all dirt, metal chips, oil, etc. Insert chuck or face mill arbor (Figure 6, Ref. Nos. 52 and 55) into spindle and rotate arbor to engage spindle key in arbor key-way. Push arbor into spindle and thread draw bar into end of arbor. Use a wrench to tighten draw bar securely.

INSTALLATION

POWER SOURCE

Refer to Figure 3, page 4.

The Palmgren mill drill is prewired for 230 volts, 60 Hz, single-phase power. A qualified electrician should wire a 240 volt, 20 AMP, 3-prong plug (not included) to mill drill line cord. Use only NEMA recommended plugs, connectors and receptacles rated on 20 amps minimum.

To use machine with a 115 volt, 60Hz, single-phase power supply:

WARNING: All electrical connections must be performed by a qualified electrician.

- Change motor wiring to 115 volts. Refer to motor nameplate for wiring schematic.
- Change setting of voltage select switch (Figure 9, Ref. No. 36) to 110 volts.
- Attach a 125 volt, 20 or 30 Amp, 3-prong plug (not included) to the mill drill line cord. Use only NEMA recommended plugs, connectors and receptacles rated on 20 amps minimum.

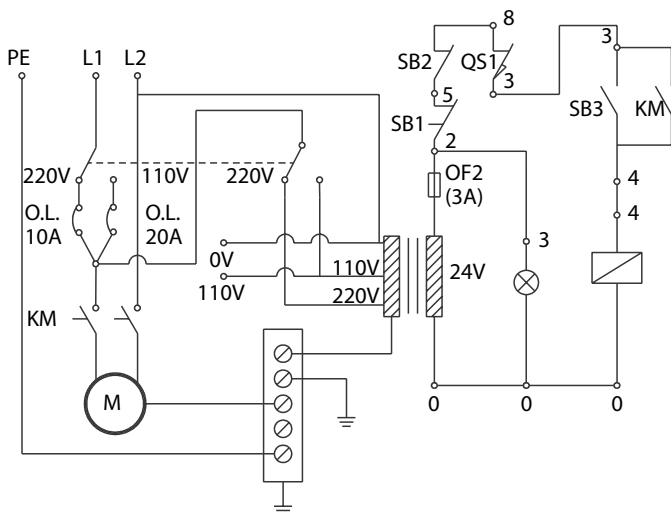

Figure 3 – Wiring Schematic

OPERATION

Refer to Figures 4, 6, 7 and 8.

ADJUSTING HEAD

Refer to Figures 6 and 8.

Loosen hex nut (Figure 6, Ref. No. 24) with wrench (Figure 6, Ref. No. 23). Head can be rotated 360° around column by hand. Be sure rack (Figure 8, Ref. No. 6) does not bind. Raise or lower head by turning head adjusting crank (Figure 6, Ref. No. 34). Be sure to tighten both hex nuts after adjusting head.

CHANGING SPEED

Palmgren mill drill is a 12-speed machine. Spindle speeds are determined by location of V-belts on three pulleys.

Always push stop button and disconnect power from machine before changing speeds.

Open cover access door. Pulley cover top can be tilted back for speed changes by sliding latches outward. Be sure to close cover when finished.

Loosen handle (Ref. No. 26) and push motor mount plate (Ref. No. 33) toward head. Tighten handle.

Loosen transmitting pulley base (Ref. No. 41) by loosening hex head bolts (Ref. No. 46). Place V-belts on pulleys for desired speed as shown in speed chart (See Figure 4, page 5).

Tension front V-belt (Ref. No. 53) by pushing middle pulley away from spindle pulley. Tighten hex head bolts.

Loosen handle and push motor mount plate away from head to tension rear V-belt. Tighten handle. Check belt tension and adjust if necessary. Close pulley cover.

Secure pulley cover latches.

Spindle RPM	Belt Location
120	A1-4Z
90	B2-4Z
230	A1-3Y
285	C3-4Z
370	B2-3Y
440	A1-2X
770	D4-3Y
1040	C3-2X
1220	B2-1W
1450	D4-2X
1800	C3-1W
2500	D4-1W

SPINDLE OPERATION

Refer to Figures 6 and 7.

Palmgren mill drill is equipped with spindle fine feed handwheel and spindle depth lockdown handle.

Engage fine feed handwheel (Figure 6, Ref. No. 2) by rotating pinion knob clockwise (Figure 6, Ref. No. 17) until tight. Disengage fine feed by loosening pinion knob.

Spindle depth can be locked into position by tightening quill lock handle (Figure 7, Ref. No. 23). Bring spindle down to desired position and tighten quill lock handle to hold spindle position.

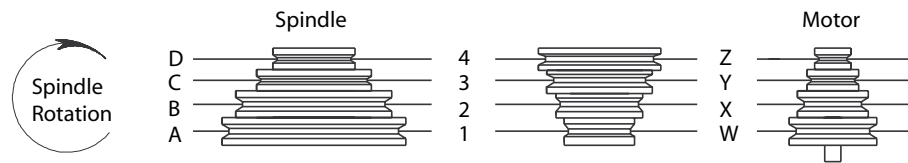
OPERATION (CONTINUED)**Figure 4 – Spindle Speed Chart****DEPTH STOP**

Refer to Figures 6 and 7.

Repeated operations where depth of cut is consistent are made easier by using depth scale (Figure 6, Ref. No. 47) and depth setting knob (Figure 7, Ref. No. 9).

Depth of cut is shown on depth scale and indicated by depth indicator (Figure 6, Ref. No. 48).

Depth of cut is set by rotating depth setting knob until desired depth is obtained.

HANDWHEEL SCALES

Refer to Figure 8.

The cross feed handwheel and right-hand longitudinal handwheel are equipped with graduated collars.

One full rotation of handwheel moves table .100". Handwheel scales are graduated in .001".

Scales are used when precise movement of table is required.

Scales can be zeroed by loosening dial screw (Ref. No. 16) and rotating lead screw dial (Ref. No. 13) until zero marks are aligned.

Tighten dial screw.

TABLE STOP BLOCKS

Refer to Figure 8.

Longitudinal travel can be limited to make repeated operations easier by using the table stop blocks (Ref. No. 40).

Table stop blocks are positioned to contact table stop bracket (Ref. No. 26) limiting table travel.

Adjust stop blocks by loosening socket head bolts (Ref. No. 39) and moving stop blocks to desired position. Secure socket head bolts.

TABLE LOCKS

Refer to Figure 8.

Mill drill table can be locked into position using table lock handles (Ref. No. 27).

Longitudinal position is secured by tightening lock handles on front of saddle.

Cross feed position is secured by tightening lock handles on right side of saddle.

REMOVE ARBOR

Loosen draw bar with wrench and remove arbor from spindle.

MAINTENANCE

Refer to Figures 5, 6, 7 and 8.

Keep all moving parts and surfaces clean of dirt, metal chips, etc. Keep a light coating of oil on all exposed surfaces, including table top and slots, all dovetail way surfaces, lead screws, rack and column.

Replace worn V-belts.

Check electrical connections and replace any worn or frayed wires or line cords.

Replace worn way cover.

GIB ADJUSTMENT

Refer to Figures 5 and 8.

Palmgren mill drill is equipped with adjustable gibs (See Figure 5) on longitudinal and cross feed that eliminate excess play in table as dovetail ways wear over time.

Rotating gib adjustment bolts (Ref. No. 25) clockwise tightens dovetail ways. Adjust gib bolts until a slight drag is felt when moving the table with handwheels. Loosen bolts if table is too tight.

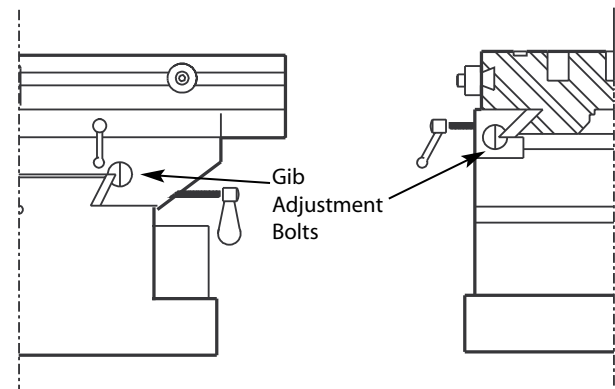
**Figure 5 – Gib Adjustment****REPLACE RETURN SPRING**

Refer to Figure 6 and 7.

Return spring may wear after extended use and will need replacement. If spindle does not return to full up position when released, then replace return spring.

CAUTION: Spring is under tension and may tend to twist forcefully when relaxed.

To replace return spring, push spindle to fully up position and lock it in place by tightening quill lock handle (Figure 7, Ref. No. 23).

Loosen spring cover knob (Figure 6, Ref. No. 38) slowly and carefully rotate spring and cover clockwise to relax spring tension.

Remove spring cover knob and washer (Figure 6, Ref. No. 38 and 40). When tension is released, rotate spring and cover clockwise to release spring from mounting screw.

Remove spring and cover. Place new spring over pinion shaft and slide slot at end of spring over mounting screw. Press spring and cover against head casting.

Replace washer and spring cover knob. Rotate cover counterclockwise to tension spring. Rotate cover approximately three full turns and tighten cover knob. Release quill lock handle.

Test spring tension by pulling down on crank handle (Figure 6, Ref. No. 19). Adjust spring tension as needed.

Overtightening spring causes quill to return with excessive force damaging quill and rubber bumper (Figure 7, Ref. Nos. 5 and 19).

MAINTENANCE (CONTINUED)**LUBRICATION**

Refer to Figures 6, 7 and 8.

Use medium weight, non-detergent oil.

DAILY:

- Apply five to six drops of oil on splines at the top of spindle (Figure 7, Ref. No. 4).
- Be sure cross feed lead screw (Figure 8, Ref. No. 20) is clean of dirt and metal chips. Oil if necessary.

WEEKLY:

- Oil cross feed lead screw (Figure 8, Ref. No. 20).
- Oil dovetail ways.

MONTHLY:

- Oil handwheel bearings through oil fittings (Figure 8, Ref. No. 19).
- Oil gear rack on back of quill where pinion shaft (Figure 6, Ref. No. 15) engages quill (Figure 7, Ref. No. 5).
- Oil depth stop lead screw (Figure 7, Ref. No. 17).
- Apply bearing grease to rack (Figure 8, Ref. No. 6) and pinion shaft (Figure 6, Ref. No. 15). Remove pinion knob and handle base (Figure 6, Ref. Nos. 17 and 20) to expose pinion shaft.
- Grease longitudinal lead screw (Figure 8, Ref. No. 35).

TROUBLESHOOTING

SYMPTOM	POSSIBLE CAUSES	CORRECTIVE ACTION
Motor does not run when start button is pushed	<ol style="list-style-type: none"> 1. No power to motor 2. Blown fuse on control box 3. Defective switch or contactor 	<ol style="list-style-type: none"> 1. Check electrical connector and circuit breaker or fuse 2. Correct wiring problem and replace fuse 3. Replace defective parts
Motor overheats	<ol style="list-style-type: none"> 1. Low voltage to motor 2. V-belts too tight 3. Too deep or too fast a cut 4. Worn contacts in contactor 	<ol style="list-style-type: none"> 1. Check voltage 2. Tension belts properly 3. Reduce cut depth or speed 4. Replace contactor
Spindle overheats	<ol style="list-style-type: none"> 1. Poor quill bearing lubrication 2. Spindle bearings too tight 3. Mill drill operated at high speeds for extended period 	<ol style="list-style-type: none"> 1. Lubricate bearings with bearing grease 2. Adjust bearings so that spindle does not bind 3. Allow mill drill to cool
Lack of power at spindle	V-belts loose	Tension V-belts properly
Cutting tool chattering	<ol style="list-style-type: none"> 1. Spindle bearings loose 2. Table is loose 3. Worn spindle bearings 4. Head clamp bolts loose 	<ol style="list-style-type: none"> 1. Tighten bearings 2. Adjust table and saddle gibs 3. Replace bearings 4. Tighten bolts
Spindle does not return to full "up" position	<ol style="list-style-type: none"> 1. Poorly adjusted return spring 2. Worn return spring 	<ol style="list-style-type: none"> 1. Increase return spring tension 2. Replace return spring
Excessive backlash in lead screws	Worn lead screw nuts	Replace lead screw nuts
Excessive noise	<ol style="list-style-type: none"> 1. Loose spindle bearings 2. Loose motor pulley 	<ol style="list-style-type: none"> 1. Adjust bearings properly 2. Tighten pulley set screws
Excessive play in table	Table is loose	Adjust table gibs properly

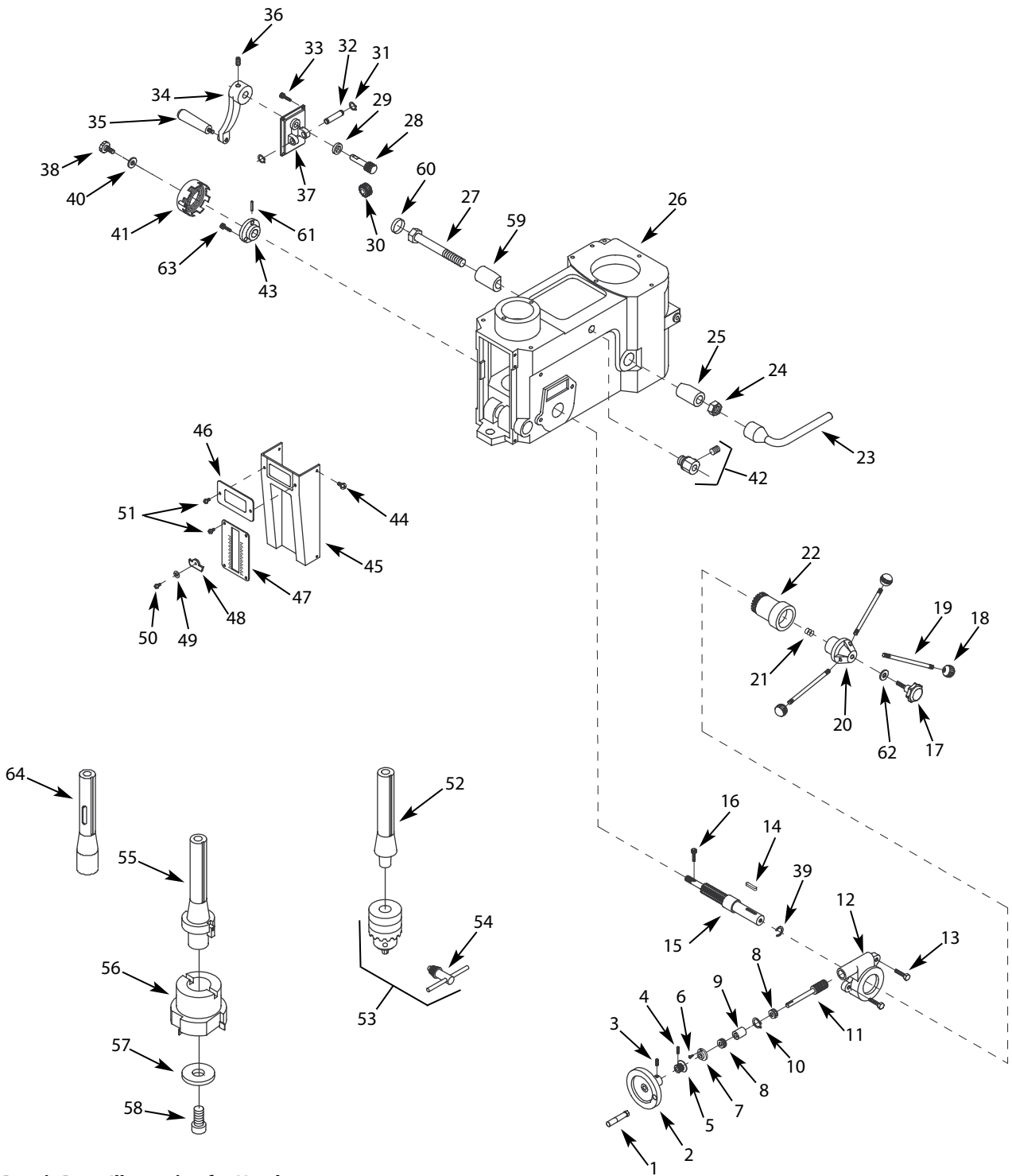

Figure 6 – Repair Parts Illustration for Head

REPLACEMENT PARTS LIST FOR HEAD

Ref. No.	Description	Part No.	Qty.	Ref. No.	Description	Part No.	Qty.
1	Handle	05911.01	1	34	Head adjusting crank	05901.01	1
2	Handwheel	17147.00	1	35	Handle	04006.00	1
3	8-1.25 x 10mm Set screw	*	1	36	10-1.5 x 8mm Set screw	*	1
4	6-1.0 x 8mm Set screw	*	1	37	Pinion housing	16489.00	1
5	Fine feed scale	05895.01	1	38	Knob	05866.01	1
6	5-0.8 x 10mm Pan head screw	*	2	39	Retaining clip	15350.00	1
7	Worm cover	05894.01	1	40	1/4" Flat washer	*	1
8	6202ZZ Ball bearing	1L015	2	41	Return spring and cover	05881.00	1
9	Spacer	05893.00	1	42	Strain relief	00582.00	1
10	3 AMI-15 Retaining ring	00533.00	1	43	Spring base	05882.00	1
11	Worm shaft	05892.01	1	44	6-1.0 x 12mm Washer head screw	*	4
12	Fine feed housing	05891.00	1	45	Front cover	05875.01	1
13	8-1.25 x 25mm Socket head bolt	*	2	46	Warning label	05877.01	1
14	7 x 7 x 20mm Key	05889.00	1	47	Depth scale	05876.01	1
15	Pinion shaft	17148.00	1	48	Depth indicator	05874.00	1
16	5-0.8 x 10mm Flat head screw	*	1	49	3mm Flat washer	*	1
17	Pinion knob	05883.00	1	50	3-0.5 x 16mm Pan head screw	*	1
18	Handle knob	05886.00	3	51	3.5-1.3 x 8mm Tapping screw	17155.00	6
19	Crank handle	17218.00	3	52	R8 to JT3 Arbor	15214.00	1
20	Handle base	17149.00	1	53	JT3 Chuck with key (Ref. No. 54)	15351.00	1
21	Compression spring	17150.00	1	54	Chuck key	15352.00	1
22	Ring gear housing	17151.00	1	55	Face mill arbor	17156.00	1
23	Wrench	17152.00	1	56	Face milling cutter	15354.00	1
24	12-1.75mm Hex nut	*	1	57	Retaining plate	15355.00	1
25	Bushing	17153.00	1	58	10-1.5 x 25mm Socket head bolt	*	1
26	Head	17154.09	1	59	Bushing	16491.00	1
27	12-1.75 x 120mm Hex head bolt	*	1	60	32 x 7mm Oil seal	16492.00	1
28	Worm shaft	05900.00	1	61	3 x 12mm Spring pin	06396.00	2
29	Bushing	05972.00	1	62	10mm Flat Washer	*	1
30	Worm gear	05899.00	1	63	5-0.8 x 20mm Pan head screw	*	3
31	3 AMI-14 Retaining ring	05989.00	2	64	R8/3MT Adapter	17157.00	1
32	Worm gear shaft	16488.00	1	Δ	Operator's Manual	20953.09	1
33	6-1.0 x 20mm Socket head bolt	*	4				

* Standard hardware item available locally.

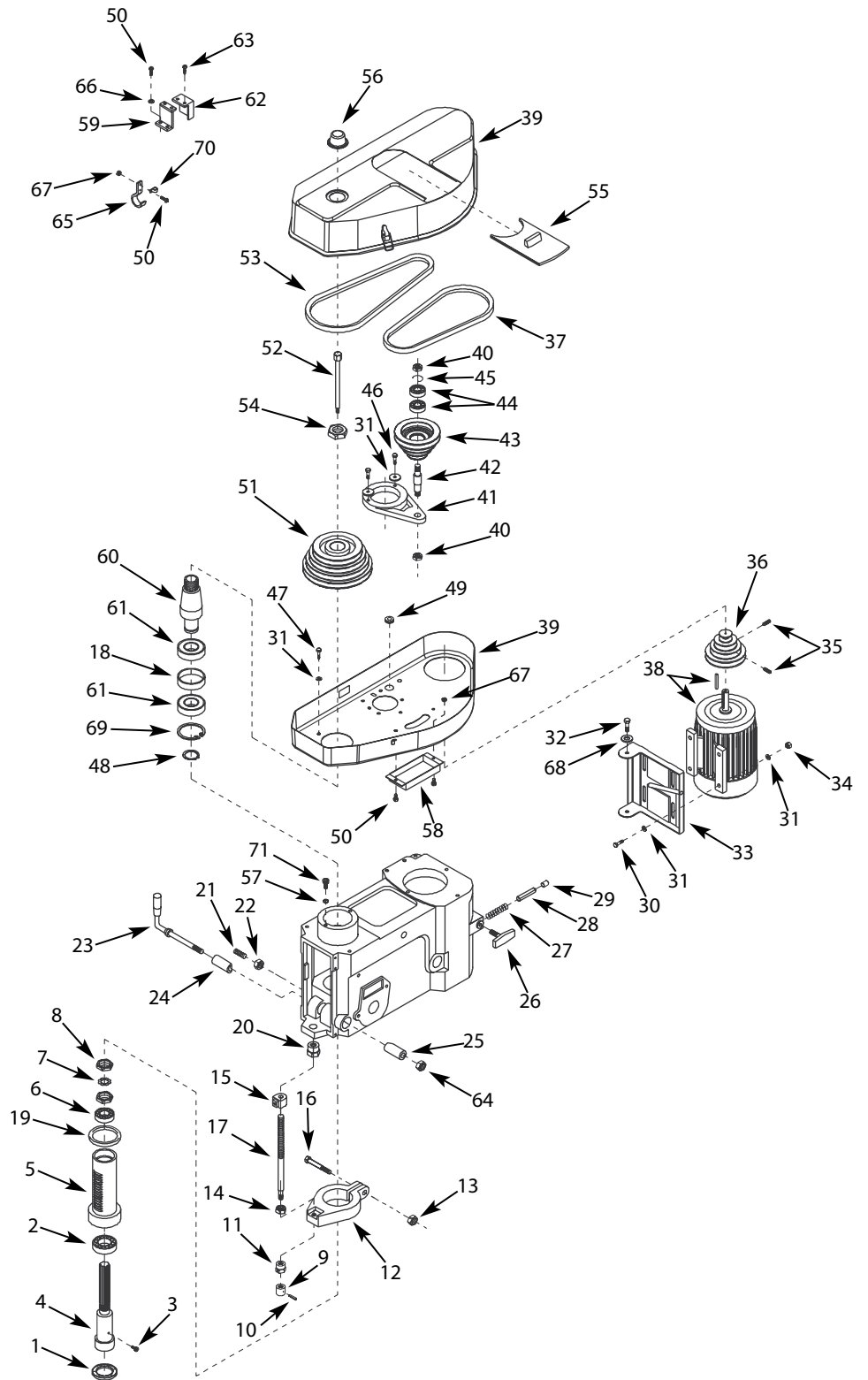

Figure 7 – Repair Parts Illustration for Head

REPLACEMENT PARTS LIST FOR HEAD

Ref. No.	Description	Part No.	Qty.	Ref. No.	Description	Part No.	Qty.
1	45 x 72 x 8mm Oil seal	15357.00	1	37	V-belt	05665.00	1
2	30207 J-N Taper bearing	05855.00	1	38	Motor and key	17206.00	1
3	4-0.7 x 8mm Socket head bolt	*	1	39	Pulley cover	17166.00	1
4	Spindle	17158.00	1	40	16-2.0mm Hex nut	*	2
5	Quill	05852.01	1	41	Transmitting pulley base	17167.00	1
6	30206 J-N Taper bearing	05856.00	1	42	Transmitting pulley shaft	17168.00	1
7	30mm Keyed washer	17159.00	1	43	Transmitting pulley	05910.00	1
8	30-1.25mm Spanner nut	05858.00	2	44	6204ZZ Bearing	00989.00	2
9	Depth setting knob	05867.01	1	45	54mm Retainer ring	05975.00	1
10	4 x 18mm Spring pin	02783.00	1	46	8-1.25 x 35mm Hex head bolt	*	2
11	Rod bushing	17160.00	1	47	8-1.25 x 16mm Hex head bolt	*	5
12	Rod base	05869.01	1	48	41mm Retainer ring	05973.00	1
13	6-1.0mm Hex nut	*	1	49	Grommet	04076.00	1
14	16-2.0mm Hex jam nut	*	1	50	5-0.8 x 12mm Pan head screw	*	6
15	Depth indicator block	17161.00	1	51	Spindle pulley	05864.00	1
16	6-1.0 x 50mm Hex head bolt	*	1	52	Draw bar	05921.00	1
17	Depth stop lead screw	05872.00	1	53	V-belt	04106.00	1
18	Spacer	17171.00	1	54	Spindle lock nut	05343.01	1
19	Rubber bumper	05859.00	1	55	Cover access door	17169.00	1
20	Rod bushing	17162.00	1	56	Draw bar cover	17170.00	1
21	10-1.5 x 40mm Dog point set screw	02576.00	1	57	6mm Flat washer	*	2
22	10-1.5mm Hex nut	*	1	58	Cover	15343.00	1
23	Quill lock handle	17163.00	1	59	Plate	17172.00	1
24	Quill lock bushing	17164.00	1	60	Spindle taper sleeve	05345.01	1
25	Quill lock sleeve	16499.00	1	61	6009ZZ Bearing	05860.00	2
26	Handle	17165.00	1	62	Cover	15345.00	1
27	Compression spring	05905.00	1	63	4-0.7 x 6mm Pan head screw	*	2
28	Tension rod	05906.00	1	64	12-1.75mm Hex nut	*	1
29	Rod cap	05907.01	1	65	Switch plate	17173.00	1
30	8-1.25 x 25mm Hex head bolt	*	4	66	5mm Flat washer	*	2
31	8mm Flat washer	*	14	67	5-0.8mm Hex nut	*	4
32	10-1.5 x 25mm Hex head bolt	*	2	68	10mm Flat washer	*	2
33	Motor mount plate	05912.01	1	69	86mm Retainer ring	05902.00	1
34	8-1.25mm Hex nut	*	4	70	Clamp	02702.00	1
35	8-1.25 x 10mm Set screw	*	2	71	6-1.0 x 15mm Socket head bolt	*	2
36	Motor pulley	05914.00	1				

* Standard hardware item available locally.

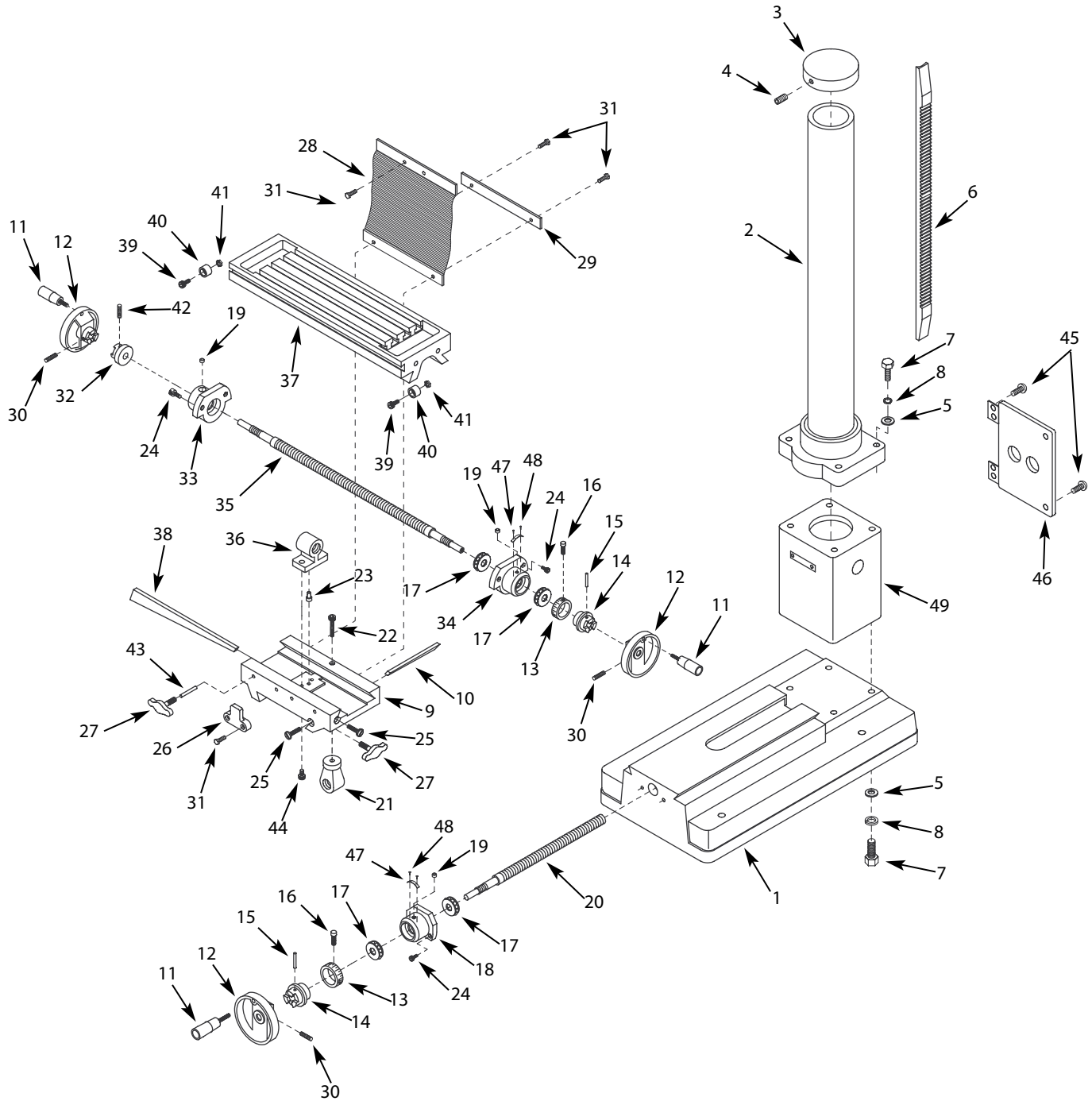

Figure 8 – Repair Parts Illustration for Base

REPLACEMENT PARTS LIST FOR BASE

Ref. No. Description	Part No.	Qty.	Ref. No. Description	Part No.	Qty.
1 Base	17174.09	1	27 Table lock handle	15348.00	4
2 Column	16378.09	1	28 Way cover	05941.01	1
3 Column cap	17175.00	1	29 Lower cover plate	05942.00	1
4 8-1.25 x 8mm Set screw	*	1	30 1/4-20 x 3/8" Set screw	*	3
5 12mm Flat washer	*	8	31 8-1.25 x 15mm Hex head bolt	*	6
6 Rack	05926.00	1	32 Left lead screw coupling	17183.00	1
7 12-1.75 x 50mm Hex head bolt	*	8	33 Left lead screw flange	05945.00	1
8 12-1.75mm Lock washer	*	8	34 Right lead screw flange	05946.01	1
9 Saddle	17176.00	1	35 Longitudinal lead screw	05947.01	1
10 Saddle gib	17177.00	1	36 Longitudinal lead screw nut	17184.00	1
11 Handle	04006.00	3	37 Table	17185.00	1
12 Handwheel	05931.00	3	38 Table gib	17186.00	1
13 Lead screw dial	17178.00	2	39 6-1.0 x 16mm Socket head bolt	*	2
14 Lead screw coupling	05933.00	2	40 Stop block	05951.01	2
15 5 x 40mm Spring pin	05934.00	2	41 Stop block nut	17187.00	2
16 6-1.0 x 10mm Dial screw	17179.00	2	42 10-1.5 x 10mm Set screw	*	1
17 51103 Thrust bearing	05935.00	4	43 1/4 x 1" Brass dowel pin	16496.00	2
18 Cross feed flange	05936.01	1	44 8-1.25 x 25mm Socket head bolt	*	2
19 Oil fitting	05979.00	3	45 6-1.0 x 12mm Washer head screw	*	6
20 Cross feed lead screw	05937.01	1	46 Cover plate	15332.09	1
21 Cross feed lead screw nut	17180.00	1	47 Scale	15334.00	2
22 8-1.25 x 50mm Socket head bolt	*	1	48 Rivet	01286.00	4
23 Pin	17181.00	1	49 Column support	17188.09	1
24 8-1.25 x 20mm Socket head bolt	*	6	Recommended Accessories		
25 Gib adjustment bolt	17182.00	2	Δ Power Feed Accessory	80162	1
26 Table stop bracket	05939.00	1			

Δ Not Shown.

* Standard hardware item available locally.

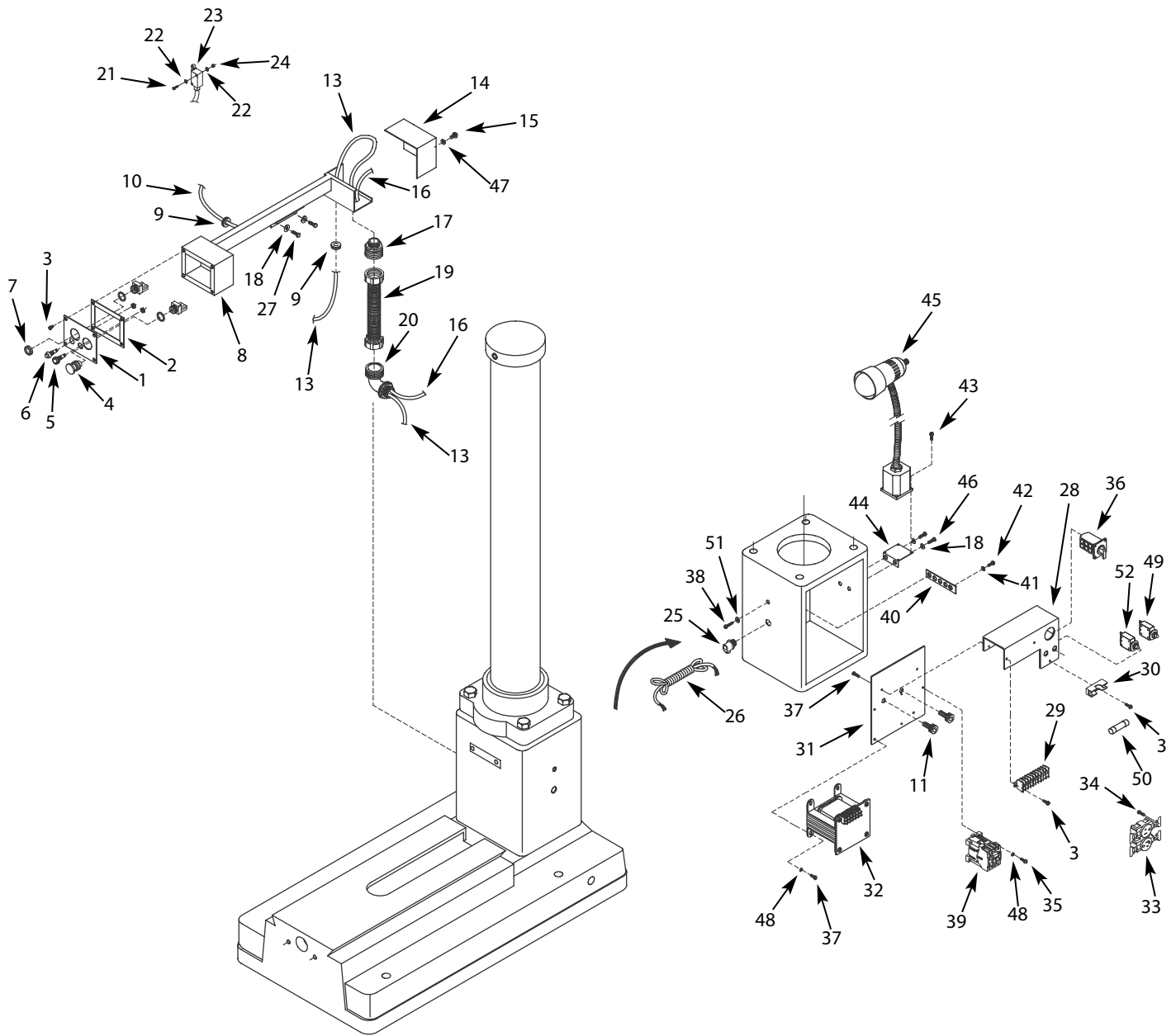

Figure 9 – Repair Parts Illustration for Control Assembly

REPLACEMENT PARTS LIST FOR CONTROL ASSEMBLY

Ref. No.	Description	Part No.	Qty.	Ref. No.	Description	Part No.	Qty.
1	Control box face plate	17189.00	1	30	Fuse holder	17205.00	1
2	Gasket	17190.00	1	31	Plate	17195.09	1
3	4-0.7 x 8mm Round head screw	*	7	32	Transformer	17196.00	1
4	Emergency stop switch	15337.00	1	33	Recepticle	16376.00	2
5	Power lamp	15338.00	1	34	3.5-0.6 x 10mm Oval countersunk screw	*	4
6	Stop switch	15339.00	1	35	4.2-1.4 x 16mm Tapping screw	17197.00	2
7	Start switch	15310.00	1	36	Voltage select switch	17204.00	1
8	Control box housing	17191.09	1	37	4.2-1.4 x 8mm Tapping screw	17198.00	6
9	Grommet	04076.00	2	38	5-0.8 x 25mm Socket head bolt	*	1
10	Limit switch cord	15312.00	1	39	Magnetic contactor	17199.00	1
11	8-1.25 x 16mm Socket head bolt	*	2	40	Grounding block	17200.00	1
12	5/16" Flat washer	*	2	41	5mm Serrated washer	*	3
13	Motor cord	17192.00	1	42	5-0.8 x 6mm Round head screw	*	3
14	Cover	15314.09	1	43	4-0.7 x 15mm Pan head screw	*	4
15	4-0.7 x 6mm Pan head screw	*	1	44	Plate	16497.00	1
16	Control cord	15315.00	1	45	Lamp assembly	17201.00	1
17	Upper connector	15316.00	1	46	6-1.0 x 12mm Pan head screw	*	2
18	6mm Flat washer	*	2	47	4mm Flat washer	*	1
19	Cord cover	15317.00	1	48	4mm Lock washer	*	6
20	Lower connector	15318.00	1	49	20A Circuit breaker	17203.00	1
21	3-0.5 x 16mm Pan head screw	*	2	50	3A Fuse	16479.00	1
22	3mm Flat washer	*	4	51	5mm Flat washer	*	1
23	Limit switch	15319.00	1	52	10A Circuit breaker	17202.00	1
24	3-0.5mm Hex nut	*	2	Δ	Lamp bulb	15328.00	1
25	Strain relief	00582.00	1	Δ	Lamp switch	15329.00	1
26	Line cord	05968.00	1	Δ	Lamp circuit board	17219.00	1
27	6-1.0 x 12mm Pan head screw	*	2	Δ	Lamp lens	17220.00	1
28	Plate	17193.00	1				
29	Terminal block	17194.00	1				

Δ Not Shown.

* Standard hardware item available locally.

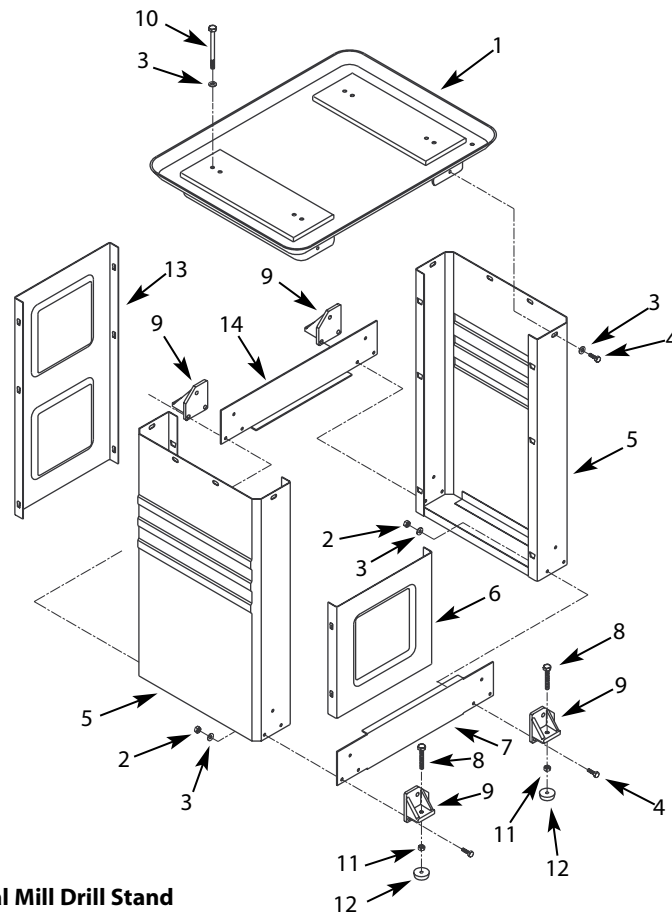

Figure 10 – Repair Parts Illustration for Optional Mill Drill Stand

REPLACEMENT PARTS LIST FOR OPTIONAL MILL DRILL STAND

Ref. No.	Description	Part Number	Qty.
1	Chip pan	17413.00	1
2	8-1.25mm Hex nut	*	12
3	8mm Flat washer	*	24
4	8-1.25 x 25mm Hex head bolt	*	20
5	Support	15301.00	2
6	Right panel	15302.00	1
7	Right plate	15303.00	1
8	12-1.75 x 50mm Hex head bolt	*	4
9	Foot	15304.00	4
10	8-1.25 x 120mm Hex head bolt	*	4
11	12-1.75mm Hex nut	*	4
12	Leveling pad	15306.00	4
13	Left panel	15307.00	1
14	Left plate	15308.00	1

* Standard hardware item available locally.

NOTES

NOTES

WARRANTY**FULL TWO YEAR WARRANTY ON PALMGREN MILL DRILL AND OPTIONAL MILL DRILL STAND**

If within two full years from the date of purchase, this Palmgren Mill Drill and Mill Drill Stand fails due to a defect in material or workmanship, Palmgren will repair it free of charge.

To order parts for a non-warranty repair, please contact your preferred Palmgren distributor. To obtain the names of Palmgren distributors or to arrange warranty return, please call Palmgren Steel Products directly at (800) 621-6145.

This warranty gives you specific legal rights and you may have other rights which vary from state to state.

Palmgren Steel Products, Inc., 914 N. Kilbourn Avenue, Chicago, IL 60651-3426

