

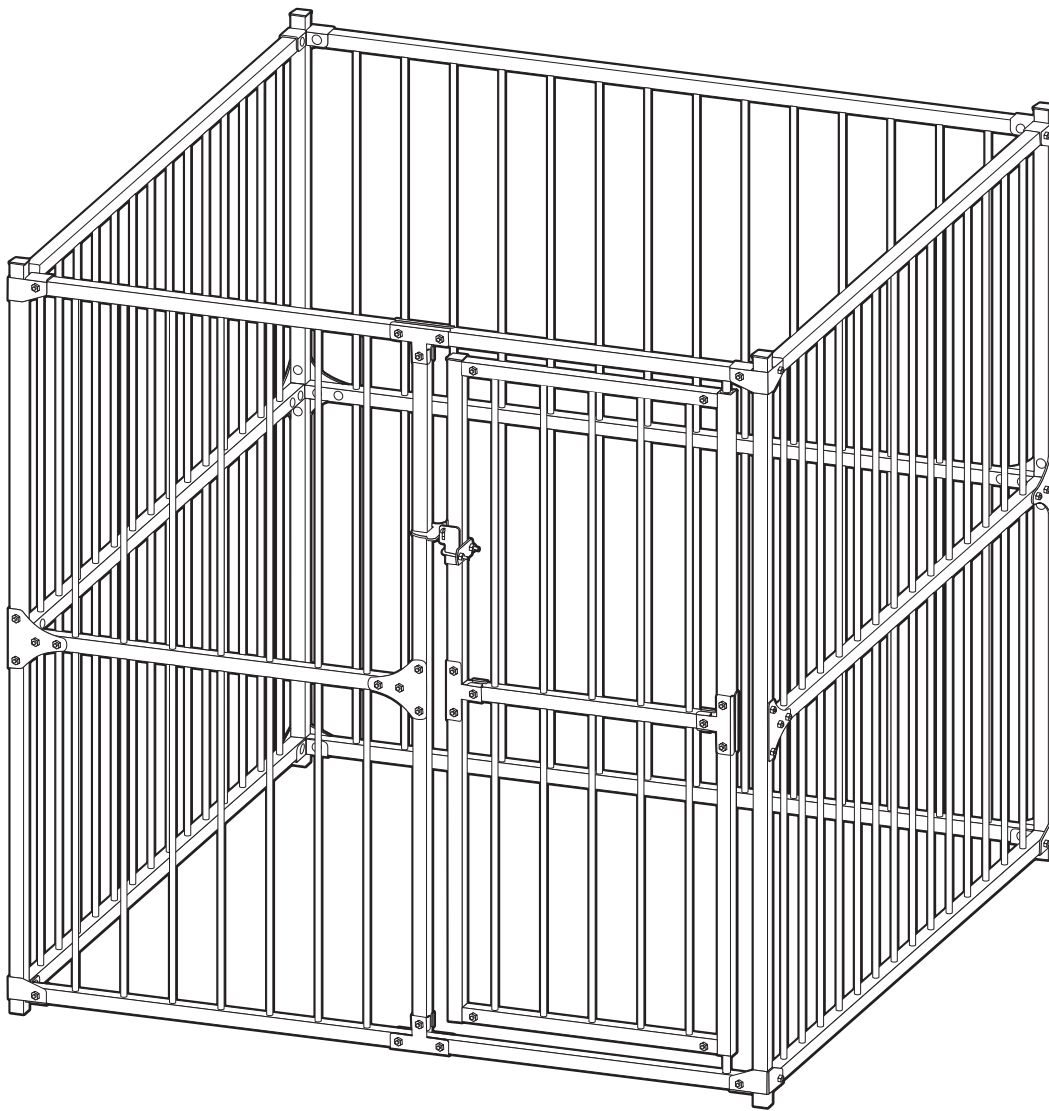

protect. teach. **love.**[™]



Model Number
HBK11-13659

5'(W) x 5'(L) x 5'(H)

laurelview dog kennel

assembly instructions

PLEASE READ THIS ENTIRE GUIDE BEFORE ASSEMBLY

Important Safety Information

Explanation of Attention Words and Symbols used in this guide



This is the safety alert symbol. It is used to alert you to potential personal injury hazards. Obey all safety messages that follow this symbol to avoid possible injury or death.

⚠ WARNING WARNING indicates a hazardous situation which, if not avoided, could result in death or serious injury.

⚠ CAUTION CAUTION, used with the safety alert symbol, indicates a hazardous situation which, if not avoided, could result in minor or moderate injury.

CAUTION CAUTION, used without the safety alert symbol, indicates a hazardous situation which, if not avoided, could result in harm to your pet.

NOTICE NOTICE is used to address safe use practices not related to personal injury.

- ⚠ WARNING**
- Not for use with aggressive dogs. Do not use this product if your dog is aggressive, or if your dog is prone to aggressive behavior. Aggressive dogs can cause severe injury and even death to their owner and others.
 - If you are unsure whether this product is appropriate for your dog, please consult your veterinarian or certified trainer.
 - Risk of Injury. Do not climb on or play around a kennel. It is not a toy or playground.

⚠ CAUTION

- Use care when handling steel tubes as they may have sharp edges. Work gloves recommended.

CAUTION

- Make sure your pet has water at all times.
- Do not kennel a dog outside in hot or cold weather without other shelter.

NOTICE

- If your area is subject to heavy snow, it is recommended that you remove the SunBlock Top™ during the winter months. Heavy snow can collapse the kennel resulting in damage and injury.
- Kennel anchors are strongly recommended. PetSafe® Anchor Kit sold separately.

Thank you for choosing PetSafe® brand. You and your pet deserve a companionship that includes memorable moments and a shared understanding together. Our products and training tools promote a lifestyle of protection, teaching, and love — essentials that influence memories for a lifetime. If you have any questions about our products or training your pet, please visit our website at www.petsafe.net or contact our Customer Care Center at 1-800-732-2677.

To get the most protection out of your warranty, please register your product within 30 days at www.petsafe.net. By registering and keeping your receipt, you will enjoy the product's full warranty and should you ever need to call the Customer Care Center, we will be able to help you faster. Most importantly, we will never give or sell your valuable information to anyone. Complete warranty information is available online at www.petsafe.net.

Table of Contents

Components.....	4
Tools Needed.....	4
Build up gate.....	5
Build up kennel	6
Install the Sunblock Top™	11
Getting Your Dog Comfortable In His Kennel	12
Caution.....	12
Terms of Use and Limitation of Liability	13
Customer Care International.....	13
Warranty.....	14

Components

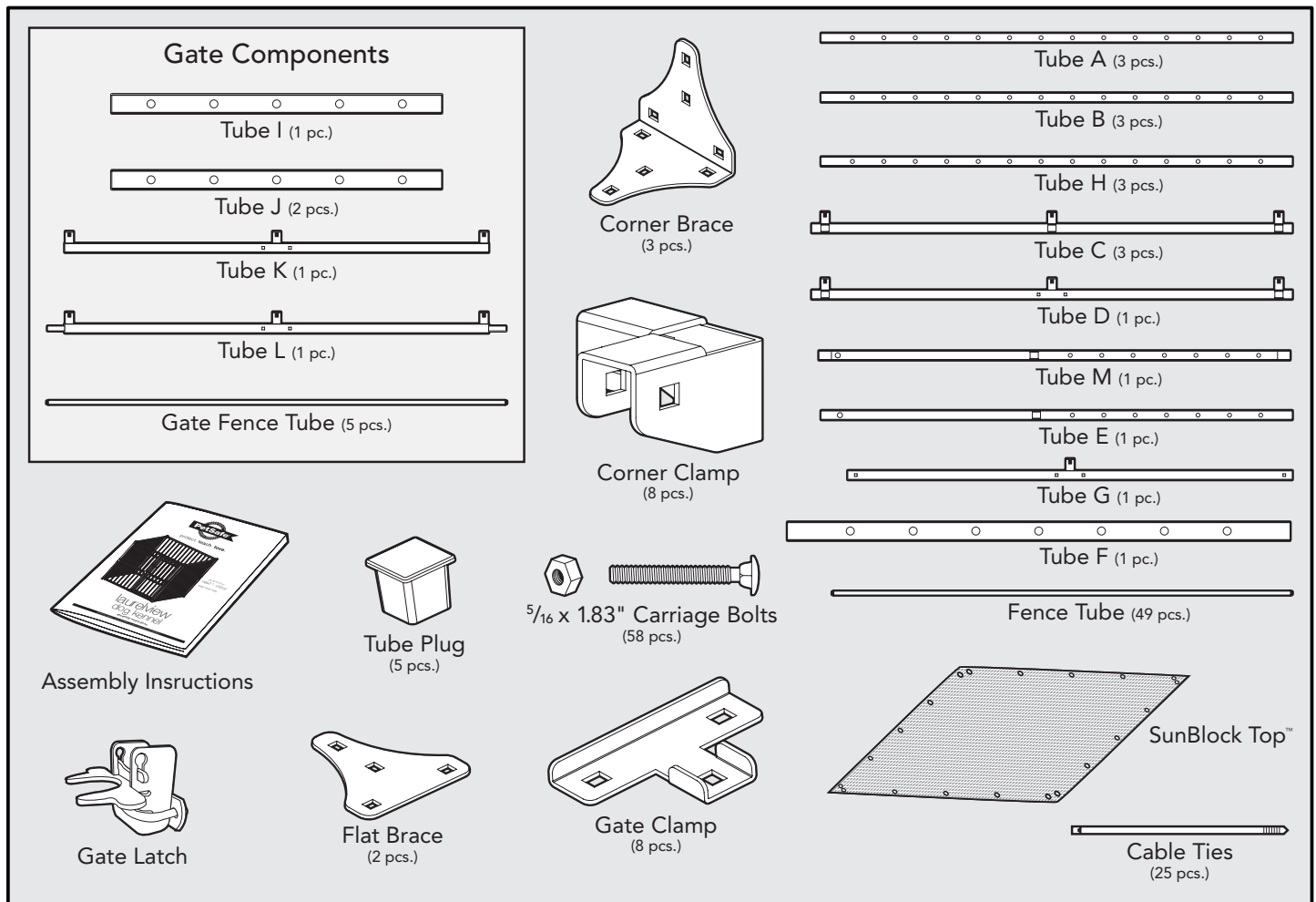

Tools Needed

- Hammer
- Adjustable Wrench or 5/16 inch wrench
- Pliers
- Tape Measure

Approximate assembly time: 40 minutes

Kennel installation help: www.petsafe.net/fence

Step 1 Build up gate

1

Important: Assemble on a level surface.

Gather (Quantity):

- (1) Tube I
- (2) Tube J
- (1) Tube K
- (1) Tube L
- (5) Gate Fence Tubes
- (4) Gate Clamp
- (10) $\frac{5}{16}$ " bolt and nut

1. Lay tube I on the ground, and insert the five Gate Fence Tubes, then assemble tube J as the picture shows. Make tube I in the middle.
2. Insert tube K and L as the picture shows. Adjust tube I to catch the clamps on tube K and L.
3. Mount the clamps, and fix the bolts. There are 10 bolts and nuts on your finished gate. Make sure all bolts toward the same direction. During installation of the gate in Steps 3-10, bolts should face the outside of the kennel.

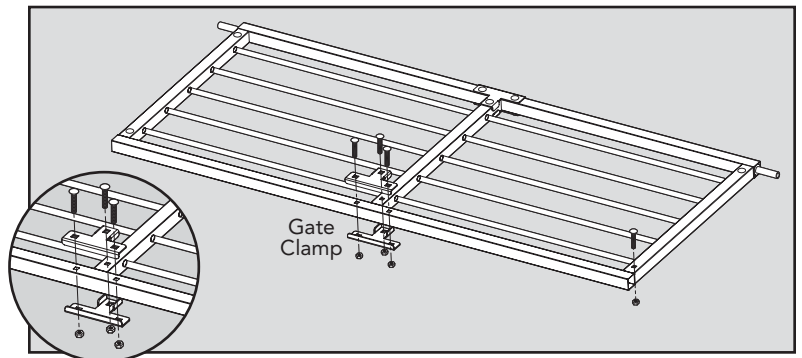
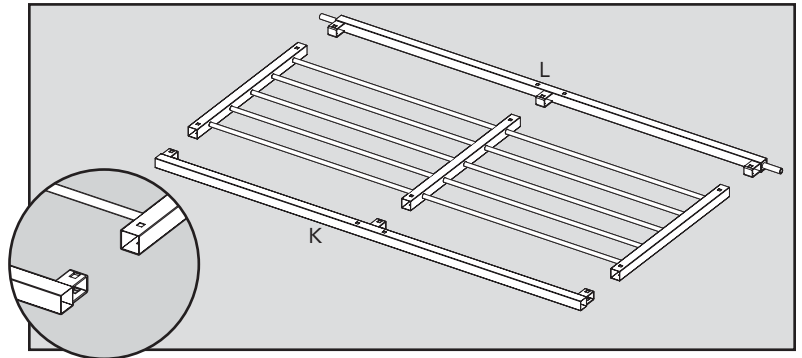
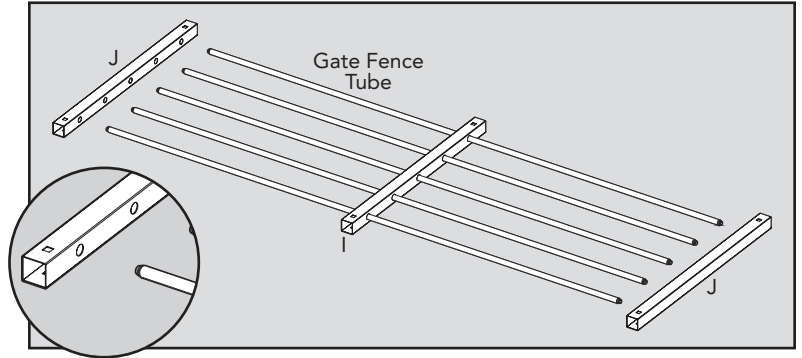

Step 2

Build up the Kennel

Gather (Quantity):

- (2) Tube A
- (1) Tube C
- (1) Corner Clamp
- (2) $\frac{5}{16}$ " bolt and nut

1. Make tube C stand up, and mount tube A to the bracket on tube C. Then mount the Corner Clamp. Mount the bolts and nuts, but do not fasten them until you complete the kennel. Some adjustment may be necessary during your work. Nuts should face outside the kennel.

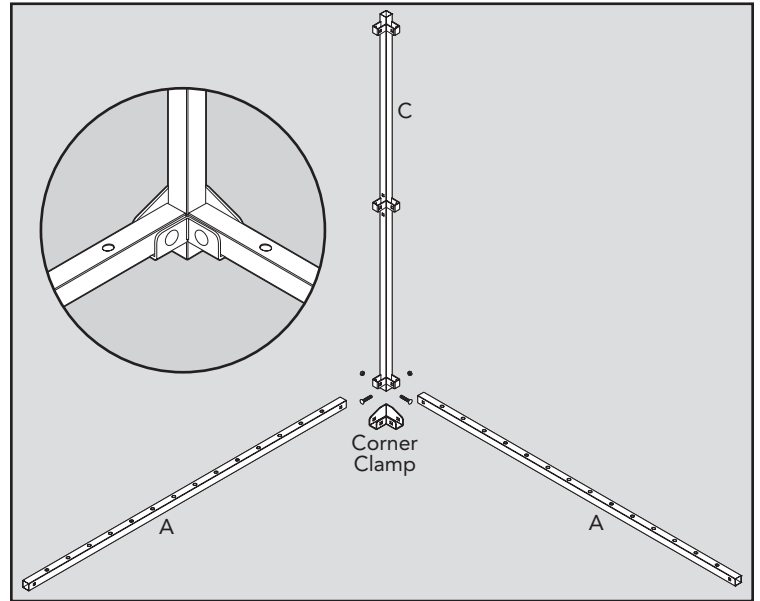

Gather (Quantity):

- (2) Tube B
- (1) Corner Brace
- (6) $\frac{5}{16}$ " bolt and nut

2. Mount tube B to the bracket on tube C. Then mount the Corner Brace. Mount the bolts and nuts, but do not fasten them until you complete the kennel. Some adjustment may be necessary during your work. Nuts should face outside the kennel.

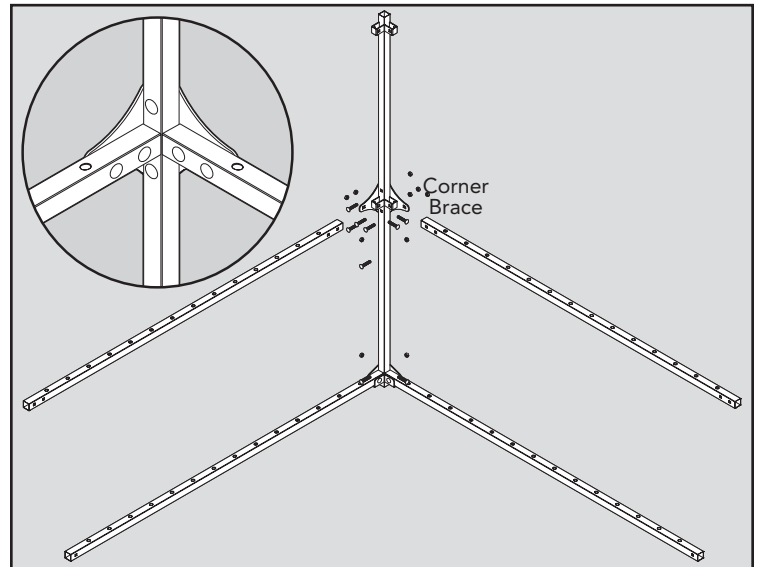

Gather (Quantity):

- (2) Tube C

3. Mount tube C to tube A and tube B. Do not mount clamps and bolts in this step.

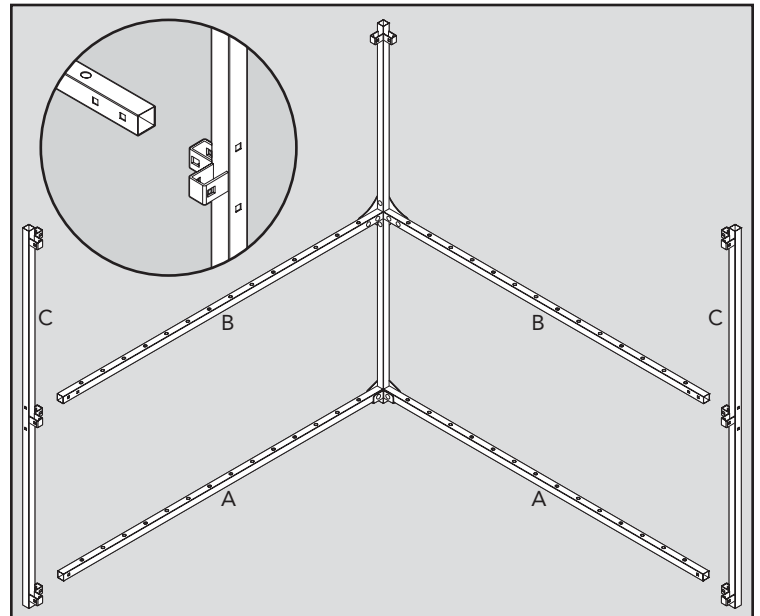

Gather (Quantity):

- (1) Tube A
- (1) Tube B

4. Mount tube A and tube B to the brackets on tube C. Do not mount clamps and bolts in this step.

Gather (Quantity):

- (1) Corner Brace
- (1) Corner Clamp
- (8) $\frac{5}{16}$ " bolt and nut

5. Mount the Corner Clamp and Corner Brace. Do not fasten them until you complete the kennel. Some adjustment may be necessary during your work.

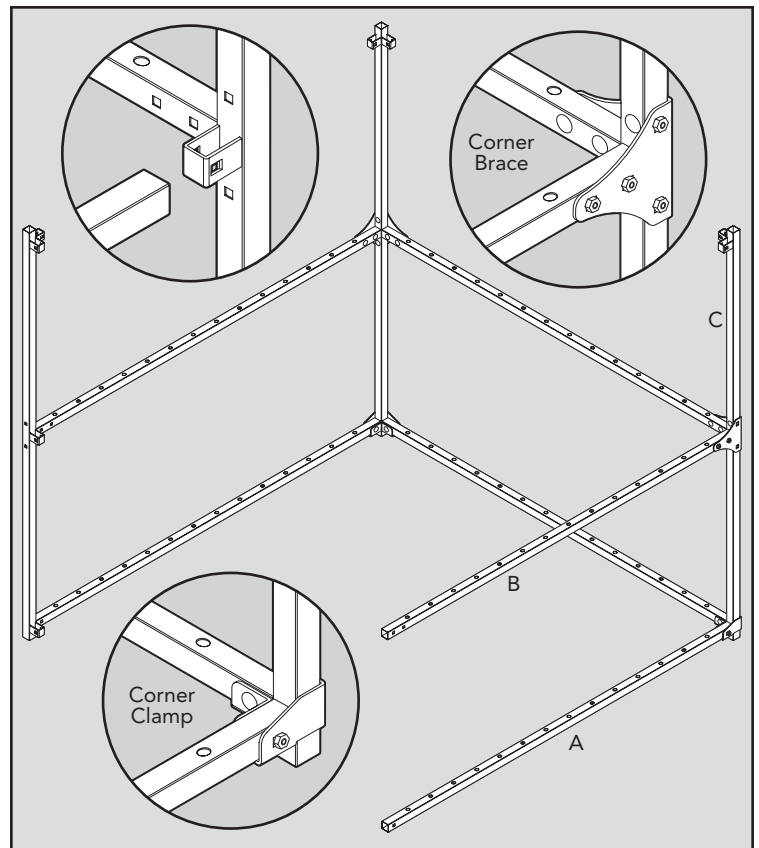

Gather (Quantity):

- (1) Tube D
- (1) Flat Brace
- (4) $\frac{5}{16}$ " bolt and nut

6. Mount tube D to the bracket on tube A and tube B. Then mount the Flat Brace. Do not fasten them until you complete the kennel. Some adjustment may be necessary during your work. Nuts should face outside the kennel.

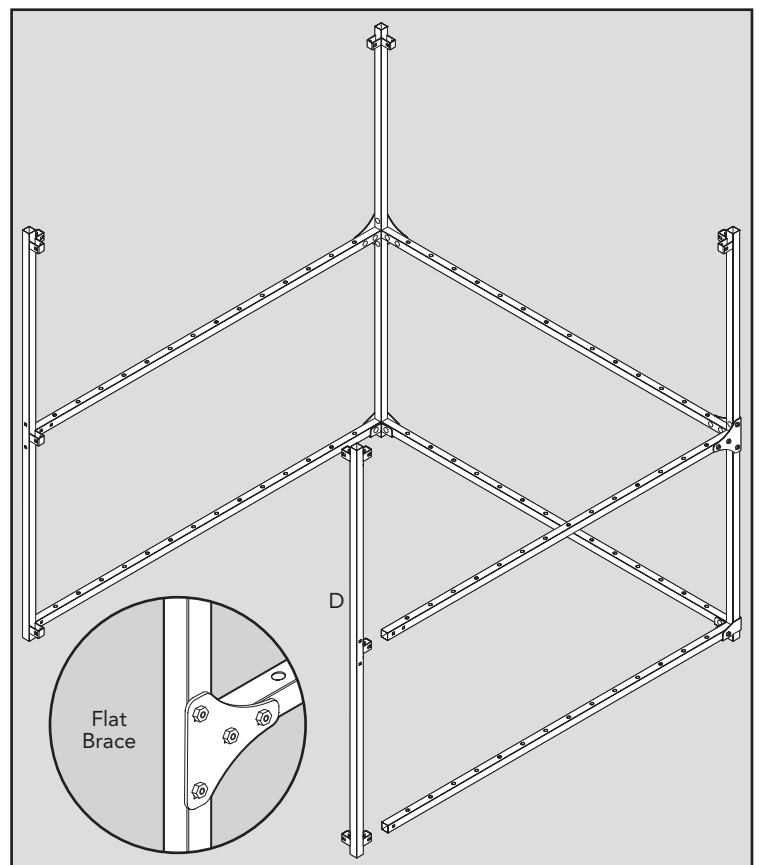

Gather (Quantity):

- (1) Tube E
 - (1) Tube F
 - (1) Tube G
7. Mount tube E to the brackets on tube C and tube D. Then mount tube F to the bracket on tube C, then insert tube G to the bracket on tube E. Finally, push tube F, and insert it to the bracket on tube G.

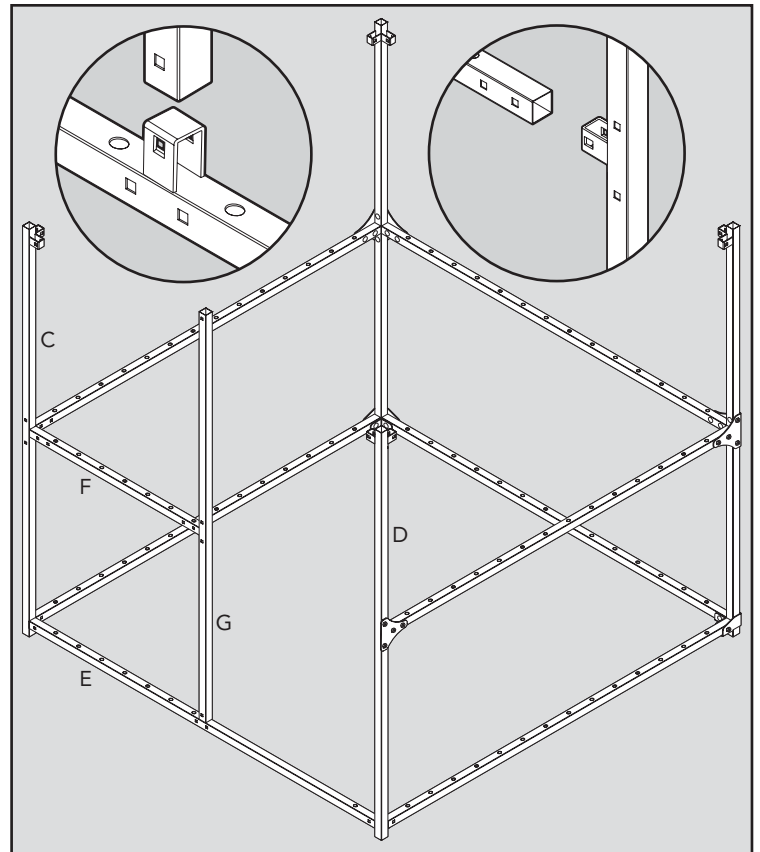

Gather (Quantity):

- (2) Corner Clamp
 - (1) Corner Brace
 - (1) Flat Brace
 - (2) Gate Clamp
 - (17) $\frac{5}{16}$ " bolt and nut
8. Mount the clamps, bolts and nuts as the steps above. Do not fasten them until you complete the kennel. Some adjustment may be necessary during your work. Nuts should face outside the kennel.

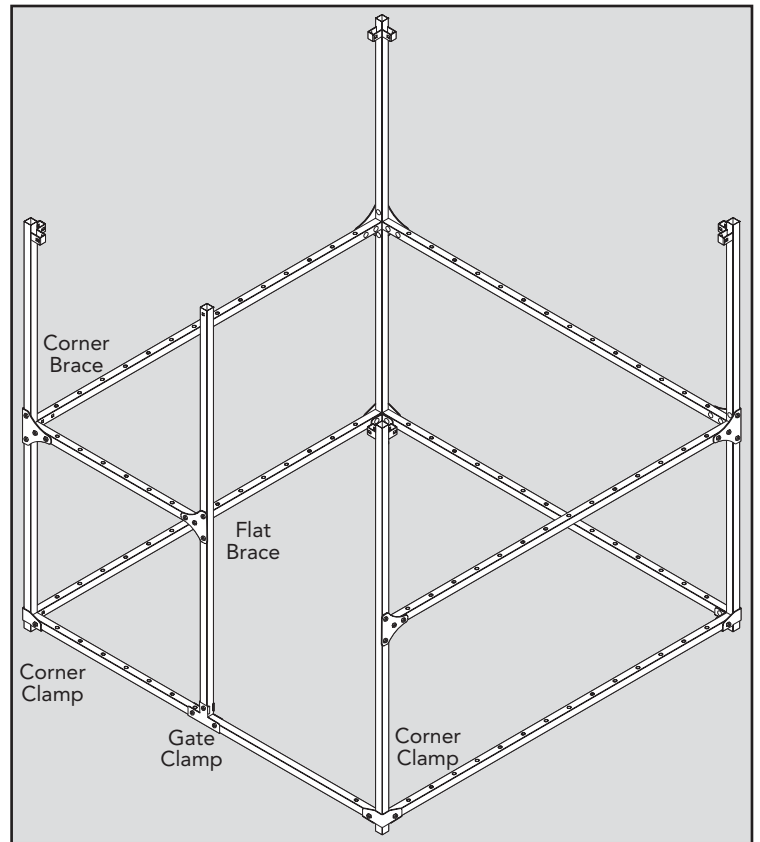

Gather (Quantity):

- (49) Fence Tube

9. Insert all 49 Fence Tubes.

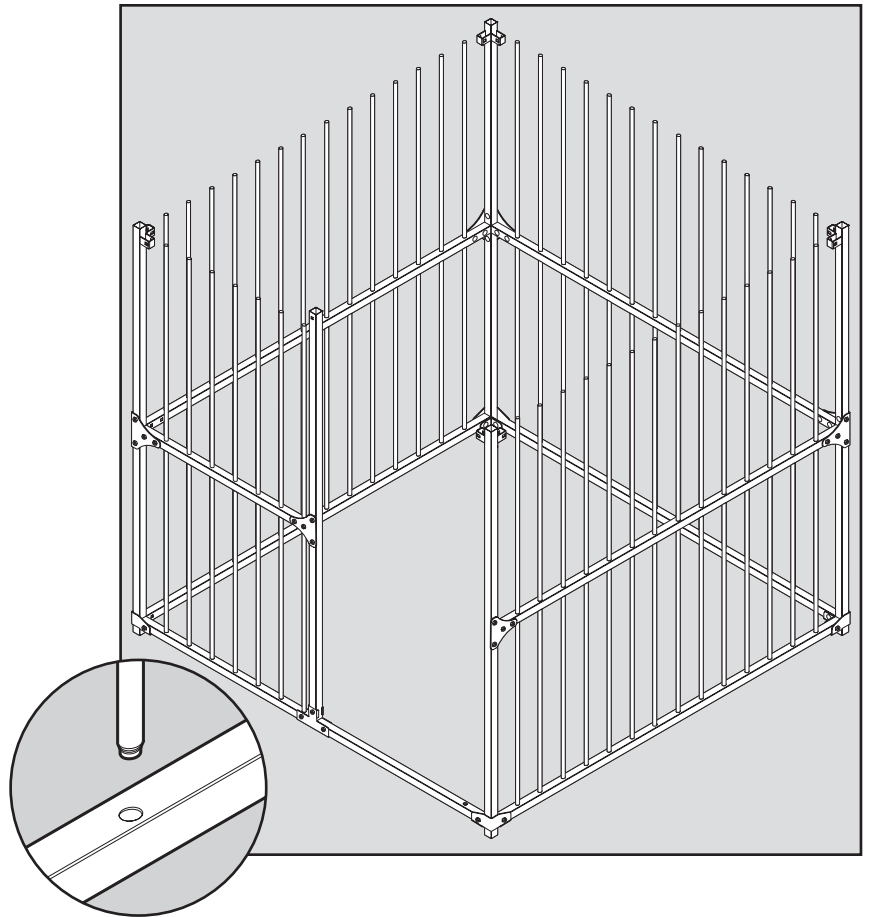

Gather (Quantity):

- (1) Gate, assembled in Step 1.

10. Insert the gate. Nuts should face outside the kennel.

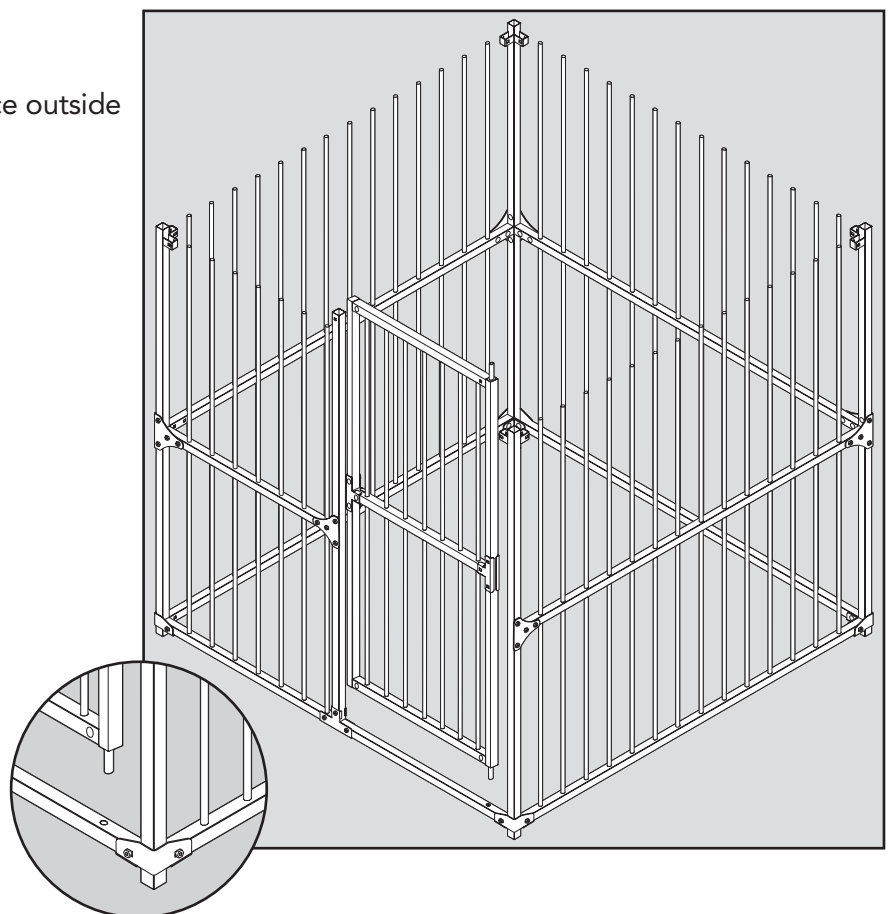

Gather (Quantity):

- (1) Tube M
- (3) Tube H

11. Mount tube M. Make sure each fence tube gets into the right hole. Then mount tube H.

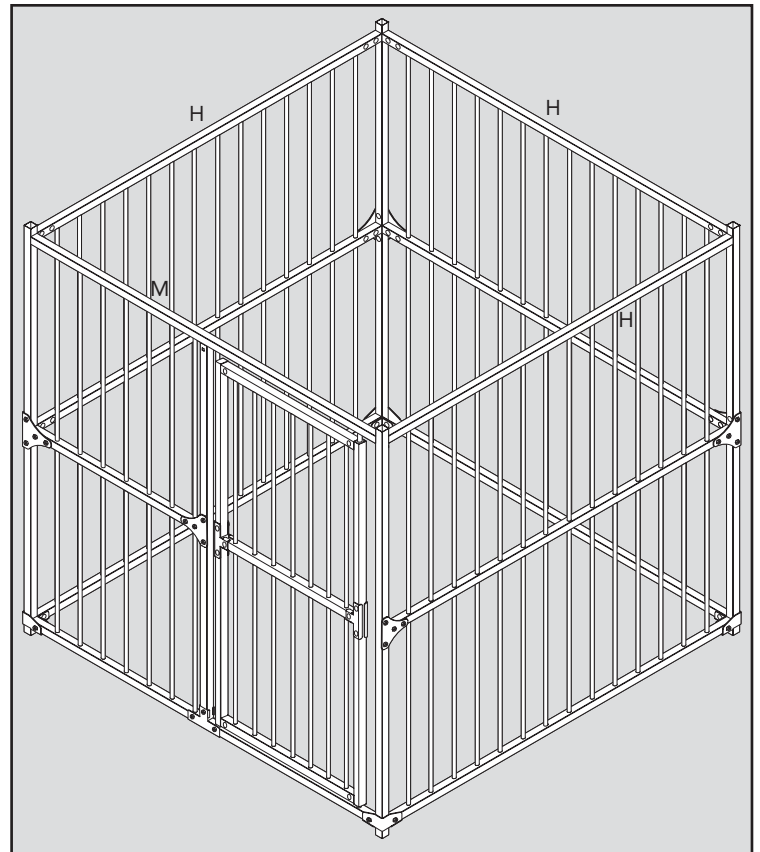

Gather (Quantity):

- (4) Corner Clamp
- (2) Gate Clamp
- (11) $\frac{5}{16}$ " bolt and nut

12. Mount the clamps, bolts and nuts. Do not fasten them until you complete the kennel. Some adjustment may be necessary during your work. Nuts should face outside the kennel.

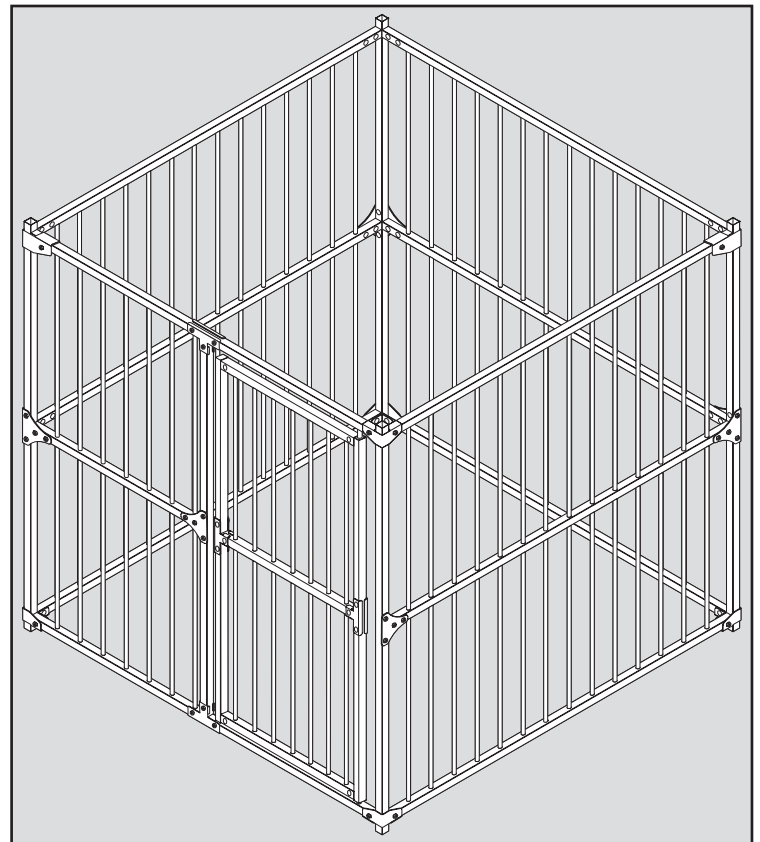

Gather (Quantity):

- (5) Tube Plug
- (1) Gate Latch

13. Knock in the 5 tube plugs. One is on the gate, the remaining four are on the kennel. Then assemble the gate latch on the gate. The latch should be mounted approximately 41 inches to the ground. A hammer is necessary when you knock the tube plugs.
14. Fasten all bolts.

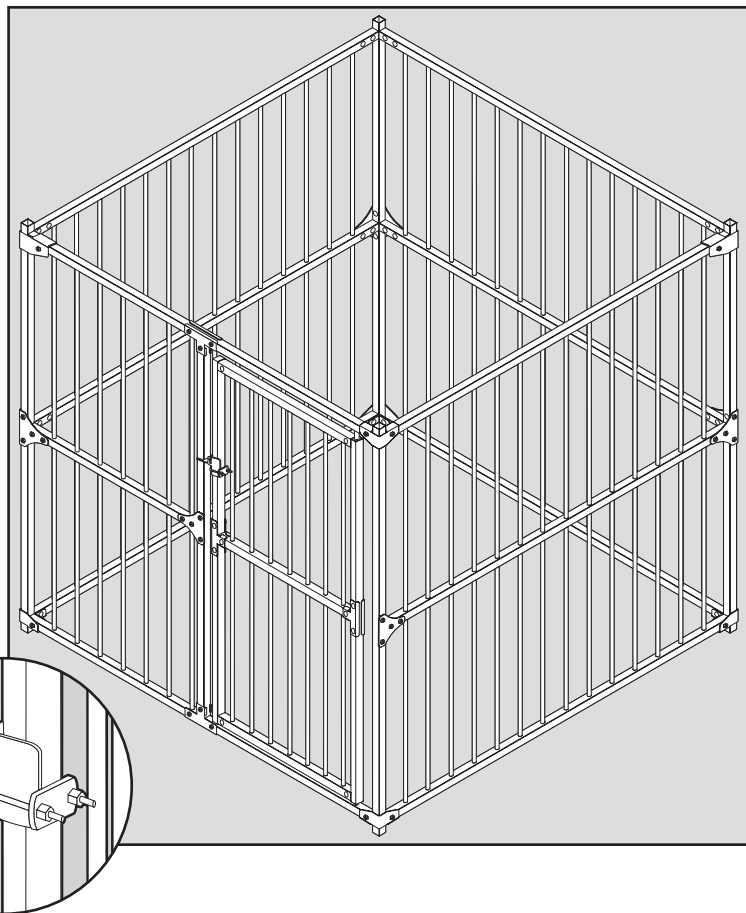

Step 3 Install the Sunblock Top™

3

Gather (Quantity):

- (1) Sunblock Top™ kit

1. Install the Sunblock Top™. Using eight of the enclosed cable ties, loosely attach the Sunblock Top™ at the corner grommets to the top rail corners of the kennel. Using the remaining cable ties, loosely attach the sides of the Sunblock Top™ to the sides of the kennel. Hand tighten all cable ties equally until Sunblock Top™ fits snug over kennel. Using wire cutters, cut off excess stems of cable ties.

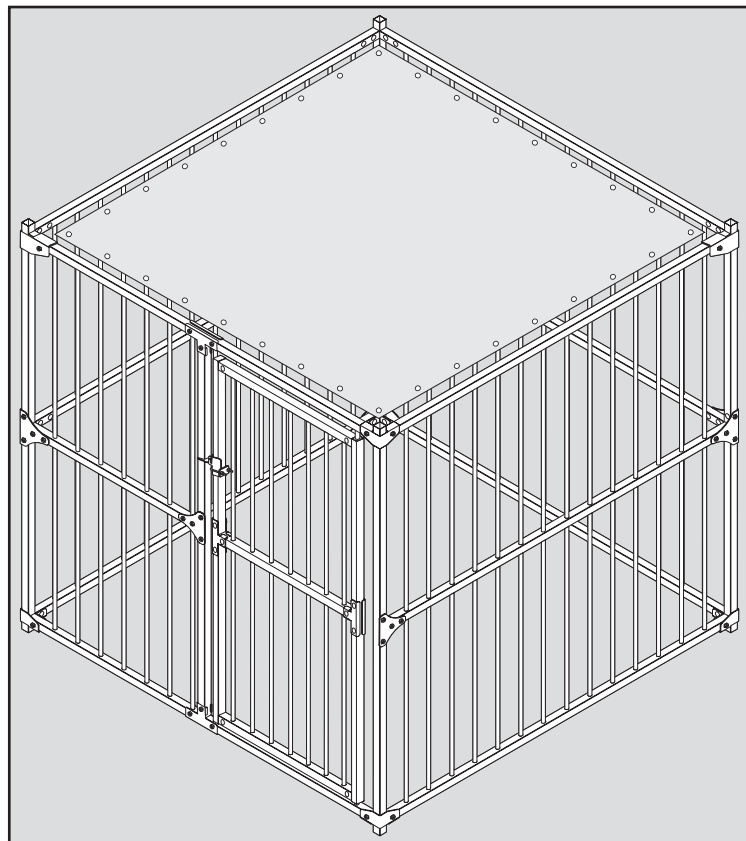

Getting Your Dog Comfortable In His Kennel

A bit of effort on your part can go a long way to ensure your dog adjusts well to his new kennel. Taking the time to introduce your dog to life in the kennel will lead to a better experience for both you and your pet. Your neighbors may be much happier too!

Kennel familiarization may take several days or even weeks, depending on your dog's age, temperament, and past experiences. It's important to keep two things in mind while kennel training: The dog kennel should always be associated with something pleasant, and training should take place in a series of small steps. Don't go too fast!

First, introduce your dog to the kennel by placing a favorite toy, blanket or beloved object into the kennel. Make sure the kennel door is open and secured so that it won't hit or frighten your dog. To encourage your dog to enter the kennel, try dropping some small food treats nearby, then just inside the door, and finally, all the way inside of the kennel. If he refuses to go all the way in the kennel at first, that's okay, don't force the issue. If he isn't interested in treats, try tossing a favorite toy in the kennel. Don't expect instant results, this process may take several days.

When he enters the kennel, offer enthusiastic verbal praise. Quietly close the gate and secure it. Never slam the gate after your dog enters. He should regard his kennel as a safe place rather than a punitive time-out area.

For best results, introduce your pet to his new kennel enclosure for brief periods over time. Stay nearby. Some pets may try to bite or chew the enclosure; some may try to climb out. Your pet may bark or whine. Verbally reassure him. Increase the length of time he is contained until you believe he's comfortable in his new kennel.

Pet toys and other familiar objects can be reassuring to our pet, and help to pass the time while he's contained. Consult your veterinarian or other pet professional to make your pet's transition to the kennel as stress-free as possible.

CAUTION

- Make sure your pet has water at all times.
- Do not kennel a dog outside in hot or cold weather without other shelter.

Caution

While this product is a solid barrier, Radio Systems® Corporation CANNOT guarantee that the system will, in all cases, keep a pet within the established boundary. Not all pets can be trained for containment. Therefore, if you have reason to believe that your pet may pose a danger to others or harm himself if he is not kept from exiting the product, you should NOT rely solely upon the PetSafe® Laurelview to contain your pet. Radio Systems Corporation shall NOT be liable for any property damage, economic loss or any consequential damages sustained as a result of any animal exiting the system. If you are unsure whether this is appropriate for your pet, please consult your veterinarian or certified trainer. This product is designed for use with pets only.

Terms of Use and Limitation of Liability

1. Terms of Use

This Product is offered to you conditioned upon your acceptance without modification of the terms, conditions and notices contained herein. Usage of this Product implies acceptance of all such terms, conditions, and notices.

2. Proper Use

This Product is designed for use with pets where training is desired. The specific temperament of your pet may not work with this Product. If you are unsure whether this is appropriate for your pet, please consult your veterinarian or certified trainer.

3. No Unlawful or Prohibited Use

This Product is designed for use with pets only. This pet training device is not intended to harm, injure or provoke. Using this Product in a way that is not intended could result in violation of Federal, State or local laws.

4. Limitation of Liability

In no event shall Radio Systems® Corporation be liable for any direct, indirect, punitive, incidental, special or consequential damages, or any damages whatsoever arising out of or connected with the use or misuse of this Product. Buyer assumes all risks and liability from the use of this Product.

5. Modification of Terms and Conditions

Radio Systems® Corporation reserves the right to change the terms, conditions and notices under which this Product is offered.

Customer Care International

USA & Canada - Tel: 800-732-2677

Monday - Friday 8 AM - 8 PM / Saturday 9 AM - 5 PM

Australia - Tel: 1800 786 608

Monday - Friday 8:30 AM - 5 PM

New Zealand - Tel: 0800 543 054

Monday - Friday 10:30 AM - 7 PM

Warranty

One Year Non-Transferrable Limited Warranty

This Product has the benefit of a limited manufacturer's warranty. Complete details of the warranty applicable to this Product and its terms can be found at www.petsafe.net.

Australia/New Zealand - In compliance with the Australian Consumer Law, Warranties Against Defects, effective January 1, 2012, warranty details of this Product are as follows:

One Year Non-Transferrable Limited Warranty

What is covered: Radio Systems Australia Pty Ltd (hereinafter referred to as "Radio Systems") warrants to the original retail purchaser, and not any other purchaser or subsequent owner, that its Product, when subject to normal and proper residential use, will be free from defects in material or workmanship for a period of one (1) year from the purchase date. An "original retail consumer purchaser" is a person or entity who originally purchases the Product, or a gift recipient of a new Product that is unopened and in its original packaging. When serviced by Radio Systems Customer Service, Radio Systems covers labor and parts for the first year of ownership; after the first year, a service or upgrade charge will apply relative to replacement of the Product with new or refurbished items at Radio System's sole discretion.

The limited warranty is non-transferrable and shall automatically terminate if the original retail consumer purchaser resells the Radio Systems Product or transfers the property on which the Radio Systems Product is installed. This Limited Warranty excludes accidental damage due to dog chews; lightning damage; or neglect, alteration, and misuse. Consumers who purchase Products outside of Australia, New Zealand, or from an unauthorized dealer will need to return the Product to the original place of purchase for any warranty issues.

Please note that Radio Systems does not provide refunds, replacements, or upgrades for change of mind, or for any other reason outside of these Warranty terms.

Claims Procedure

Any claim made under this Warranty should be made directly to Radio Systems Australia Pty Ltd Customer Care Centre at:

Radio Systems Australia Pty Ltd
PO Box 765, Mudgeeraba QLD 4213
Australia Residents: 1800 786 608
New Zealand Residents: 0800 543 054
Email: info@petsafeaustralia.com.au

To file a claim, a proof of purchase must be provided. Without a proof of purchase, Radio Systems will not repair or replace faulty components. Radio Systems requests the Consumer to contact the Radio Systems Customer Care Centre to obtain a Warranty Return number, prior to sending the Product. Failure to do so may delay in the repair or replacement of the Product.

If the Product is deemed to be faulty within 30 days from date of original purchase, Radio Systems will organise for a replacement to be sent in advance of returning the faulty Product. A Post Bag will be included with the replacement Product for the return of the faulty Product. The Product must be returned within 7 days of receiving the replacement. If the Product is deemed to be faulty after 30 days from the date of original purchase, the consumer will be required to return the Product to Radio Systems at the consumer's own expense. Radio Systems will test and replace the faulty unit or its components and return to the consumer free of charge, provided the Product is within its said warranty period. This warranty is in addition to other rights and remedies available to you under the law. Radio Systems goods come with guarantees that cannot be excluded under the Australia Consumer Law. You are entitled to a replacement or refund for a major failure and for compensation for any other reasonably foreseeable loss or damage. You are also entitled to have the goods repaired or replaced if the goods fail to be of acceptable quality and the failure does not amount to a major failure.

Should you have any queries or require any further information, please contact our Customer Care Centre on 1800 786 608 (Australia) or 0800 543 054 (New Zealand).

Radio Systems® Corporation
10427 PetSafe Way
Knoxville, TN 37932
1-888-632-4453
www.petsafe.net
400-1654/1

©Copyright 2013, Radio Systems Corpoation