



CHANGING YOUR LANDSCAPE SINCE 1945

swisherinc.com

OWNER'S MANUAL 19975

Starting Serial #: L215-001001

Commercial Pro Plow Combo, 50" ATV

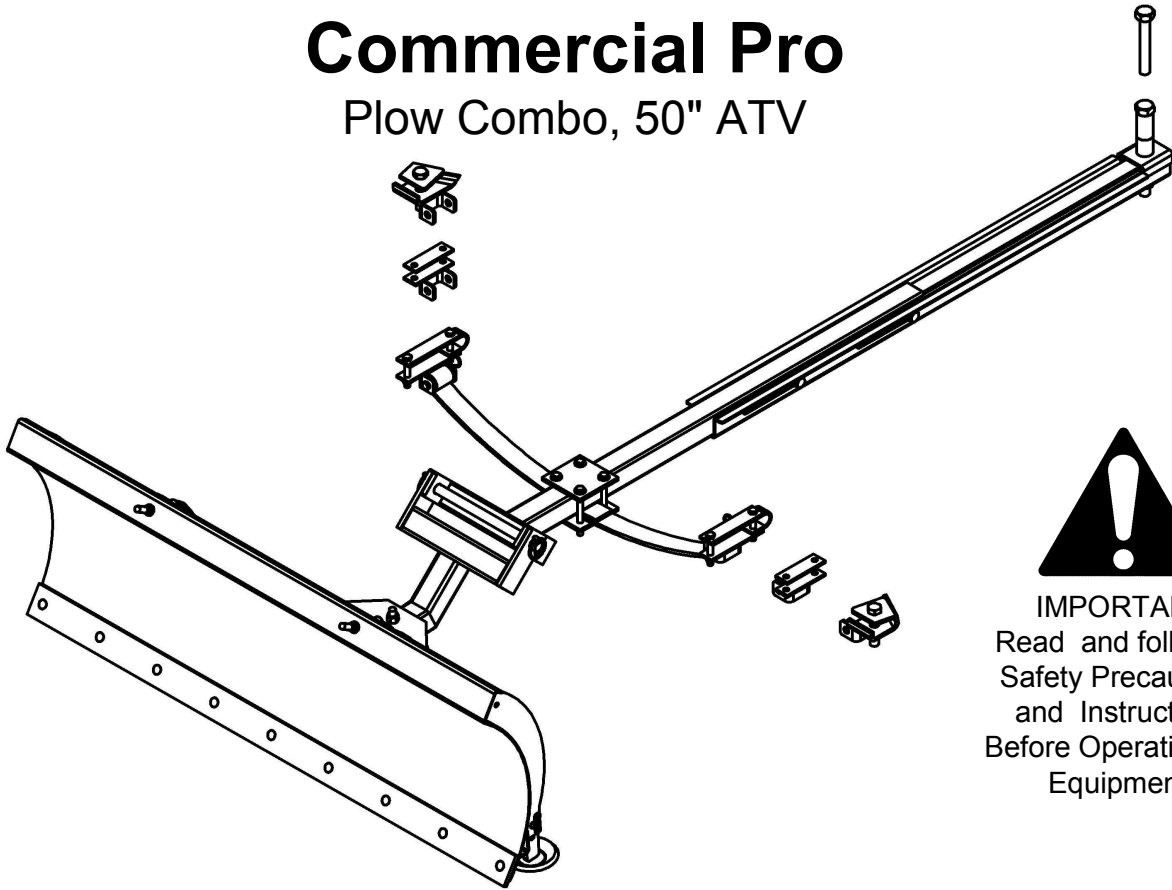

IMPORTANT
Read and follow all
Safety Precautions
and Instructions
Before Operating this
Equipment.

SWISHER

1602 CORPORATE DRIVE, WARRENSBURG, MISSOURI 64093
PHONE 660-747-8183 FAX 660-747-8650

Made In The

USA

of US and Global Parts

LIMITED WARRANTY

The manufacturer's warranty to the original consumer purchaser is: This product is free from defects in materials and workmanship for a period of one (1) year from the date of purchase by the original consumer purchaser. We will repair or replace, at our discretion, parts found to be defective due to materials or workmanship. This warranty is subject to the following limitations and exclusions:

1. Limitation This warranty applies only to products which have been properly assembled, adjusted, and operated in accordance with the instructions contained within this manual. This warranty does not apply to any product of Swisher that has been subject to alteration, misuse, abuse, improper assembly or installation, shipping damage, or to normal wear of product.
2. Exclusions Excluded from this warranty are normal wear, normal adjustments, and normal maintenance.

In the event you have a claim under this warranty, you must return the product to an authorized service dealer. All transportation charges, damage, or loss incurred during transportation of parts submitted for replacement or repair under this warranty shall be borne by the purchaser. Should you have any questions concerning this warranty, please contact us toll-free at 1-800-222-8183. The model number, serial number, date of purchase, and the name of the authorized Swisher dealer from whom you purchased the product will be needed before any warranty claim can be processed.

THIS WARRANTY DOES NOT APPLY TO ANY INCIDENTAL OR CONSEQUENTIAL DAMAGES AND ANY IMPLIED WARRANTIES ARE LIMITED TO THE SAME TIME PERIODS STATED HEREIN FOR ALL EXPRESSED WARRANTIES. Some states do not allow the limitation of consequential damages or limitations on how long an implied warranty may last, so the above limitations or exclusions may not apply to you. This warranty gives you specific legal rights and you may have other rights, which vary from state-to-state. This is a limited warranty as defined by the Magnuson-Moss Act of 1975.

SAFETY PRECAUTIONS



This Safety Alert Symbol indicates important messages in this manual. When you see this symbol, carefully read the message that follows and be alert to the possibility of personal injury.

- Read the manual. Learn to operate this machine safely.
- Keep the operating speed LOW!!!! Do not operate over 5 MPH (8 KPH).
- Allow only responsible adults who are familiar with these instructions to operate this machine. Never allow children to operate this machine.
- Be sure the area is clear of other people before operating. Children are often attracted to the machine and the operating activity. ***Never assume that children will remain where you last saw them.*** Keep children under the watchful care of another responsible adult.
- Watch for traffic when operating near or crossing roadways.
- Do not operate the attachment if it has been dropped or damaged in any manner. Repair as necessary.
- Dress properly. Do not operate when barefoot or wearing open sandals.
- Do not operate the machine while under the influence of alcohol or drugs.
- Never tamper with safety devices. Check their proper operation regularly.
- Operate attachments up and down slopes. There is significant risk of overturns when operating across slopes.
- Stop and inspect the equipment if you strike an object. Repair, if necessary, before restarting.
- Never make adjustments or repairs with the engine running.
- Some components are heavy and may require help when lifting, especially once the parts are assembled.

UNIVERSAL MOUNT PARTS DETAIL

MOUNTING OPTIONS

There are four different mounting bracket options provided for mounting to various front axle styles. Long Brackets 2632 and 2634 (13, 15) and Short Brackets 2633 and 2635 (7, 12) are two sets that will work on most ATVs. The determining factor is what type of A-arms (lower portion of the front axle) are used on your ATV. The Long Brackets are shown as an example at the bottom of this page (See Fig. 1). For some Honda models, using U-Shaped Bracket 2677 (14) in tandem with Long Brackets 2632 and 2634 (13, 15) may be necessary (See Fig. 2). Some vehicles are best suited for the Center Bolt Left & Right Brackets 2638, 2637 and 2641 (9, 10).

Note: These brackets are right and left oriented.

There are two different sizes of Bolts provided for attaching the Universal Mount to the rear ball hitch mount of the vehicle: 3/4-10 X 7 1/2 Bolt NB655 and 3/4-10 X 5 Bolt NB243 (27, 28).

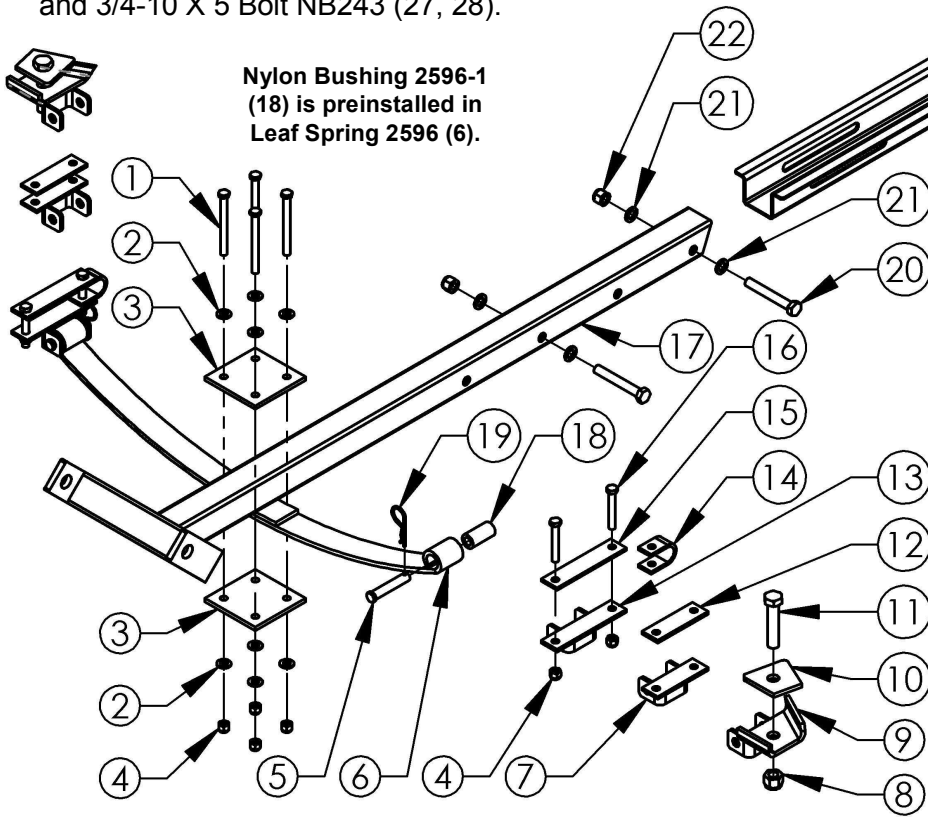
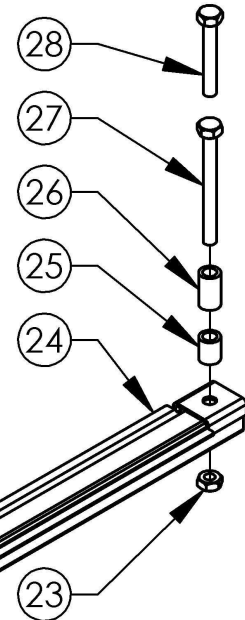
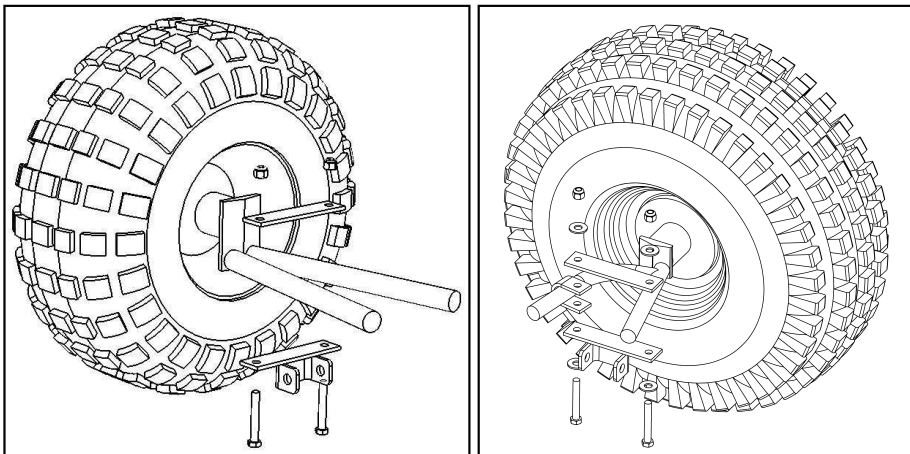

Fig. 1

Fig. 2



Item #	Part #	Description
1	NB645	Bolt - 3/8-16 X 4 HCC
2	NB272	Washer - SAE Flat 3/8
3	2631*	Plate - Spring Shackle
4	NB182	Nut - Nyloc 3/8-16
5	NB244	Pin - Clevis 1/2 X 2 3/4
6	2596*	Spring - Leaf
7	2633*	Bracket - Mount, Short
8	NB561	Nut - Nyloc 5/8-11
9	2638*	Bracket - Left Mount
	2637*	Bracket - Right Mount
10	2641*	Bracket - Backing
11	NB699	Bolt - 5/8-11 X 3
12	2635*	Bracket - Plate, Short
13	2632*	Bracket - Mount, Long
14	2677*	Bracket - U Shaped, Honda
15	2634*	Bracket - Plate, Long
16	NB619	Bolt - 3/8-16 X 2 1/2 HTC
17	20086*	Weldment - Slide Bar
18	2596-1	Bushing - Nylon
19	NB247	Pin - Hair Cotter #4
20	NB577	Bolt - 1/2-13 X 3 1/2
21	NB177	Washer - Mach 1/2
22	NB281	Nut - Nyloc 1/2-13
23	NB609	Nut - Nyloc 3/4-10
24	2630*	Mount - Channel Weldment
25	2655*	Spacer - 1.25 X .75 X 1.50
26	9609*	Spacer - 1.25 X .75 X 2.188
27	NB655	Bolt - 3/4-10 X 7 1/2
28	NB243	Bolt - 3/4-10 X 5

When ordering replacement parts

*USE PAINT CODE: GT=GREY TK=BLACK



TO ENSURE PROPER ASSEMBLY, CAREFULLY FOLLOW ALL INSTRUCTIONS LISTED BELOW

Universal Mount Assembly

1. Lay out the hardware under the ATV, as shown on the previous page. If needed, for clearance, raise the front of the ATV. Make sure the support used is very stable; do not rely on hydraulic jacks.
2. Loosely attach the Mounting Brackets best suited for your vehicle to the lower A-arms as near as possible to the inside of the wheel. See the example at the bottom of page 4. Do not securely tighten at this time.
3. Attach Leaf Spring 2596 (6) to each Mounting Bracket using Clevis Pin NB244 (5) and Hair Pin NB247 (19).
4. Attach Channel Mount 2630 (24) to the ATV ball hitch mount with 3/4-10 X 7 1/2 Bolt NB655 or 3/4-10 X 5 Bolt NB243 (27, 28) and 3/4-10 Nyloc Nut NB609 (23). Spacers 2655 and 9609 (25, 26) need to be installed to keep the Universal Mount assembly level and for clearance.
5. Insert Slide Bar Weldment 20086 (17) into Channel Mount 2630 (24). Adjust the Slide Bar Weldment (17) so the accessory mounting holes are approximately 2" ahead of the front wheels. Some adjustment may be needed after the Blade attachment is installed to ensure acceptable clearance between the attachment and the ATV. The slots in part 2630 (24) and the holes in part 20086 (17) will allow for this adjustment. Loosely fasten using 1/2-13 X 3 1/2 Bolt NB577 (20), 1/2 Washer NB177 (21) and 1/2-13 Nyloc Nut NB281 (22).
6. If previously raised, carefully lower the ATV to the ground.
7. Place the two Leaf Springs (6), from step 3 and the assembly from step 5 between the Spring Shackles 2631 (3). Loosely fasten with 3/8-16 X 4 Bolt NB645 (1), 3/8 Washer NB272 (2) and 3/8-16 Nyloc Nut NB182 (4) as shown.
8. Check the clearance between the Mounting Brackets and the ATV wheel rims by turning the ATV steering to the extreme right and then the extreme left. Adjust the location of the brackets if necessary. Make any necessary adjustments as described in step 5 then securely tighten all fasteners starting with the four Bolts (1) listed in step 7.

Removal of the Mount Assembly

Remove Hair Pins NB247 (19), pull Clevis Pins NB244 (5) and remove Bolt NB655 or NB243 (27, 28) from the ATV ball hitch mount. If possible, leave the mounting brackets attached to the A-Arms.

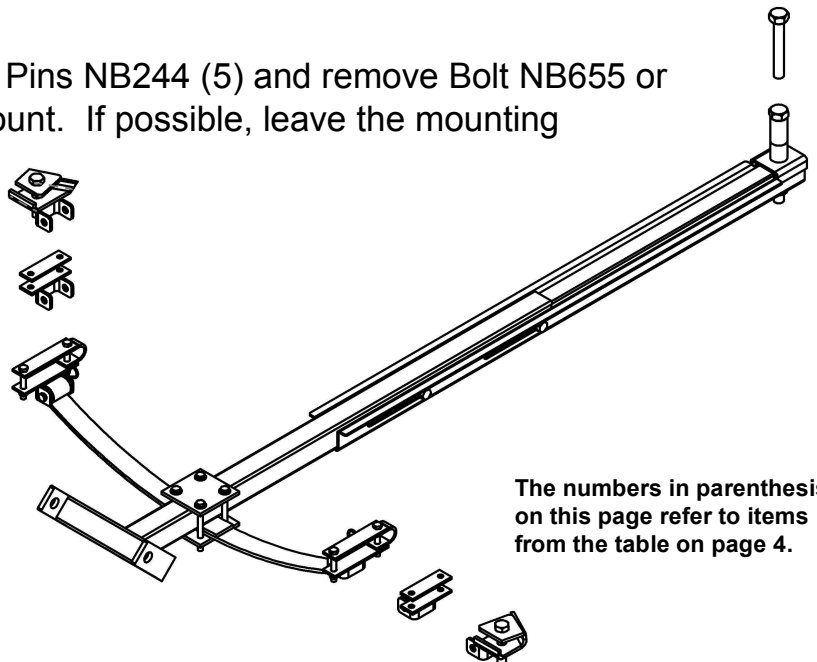

NOTE: The CV guards on your ATV may need to be trimmed or otherwise modified to allow for installation and proper clearance for the Accessory Mount. Check with the vehicle mfg prior to making modifications as such modifications could void the mfg warranty.

The numbers in parenthesis on this page refer to items from the table on page 4.

PLOW PARTS DETAIL

Cut Edge 20084 (9) is preinstalled to Blade 2150 (29) using 5/16-18 X 1 Carriage Bolt 10197 (8) and 5/16-18 Serrated Flange Nut NB170 (11).

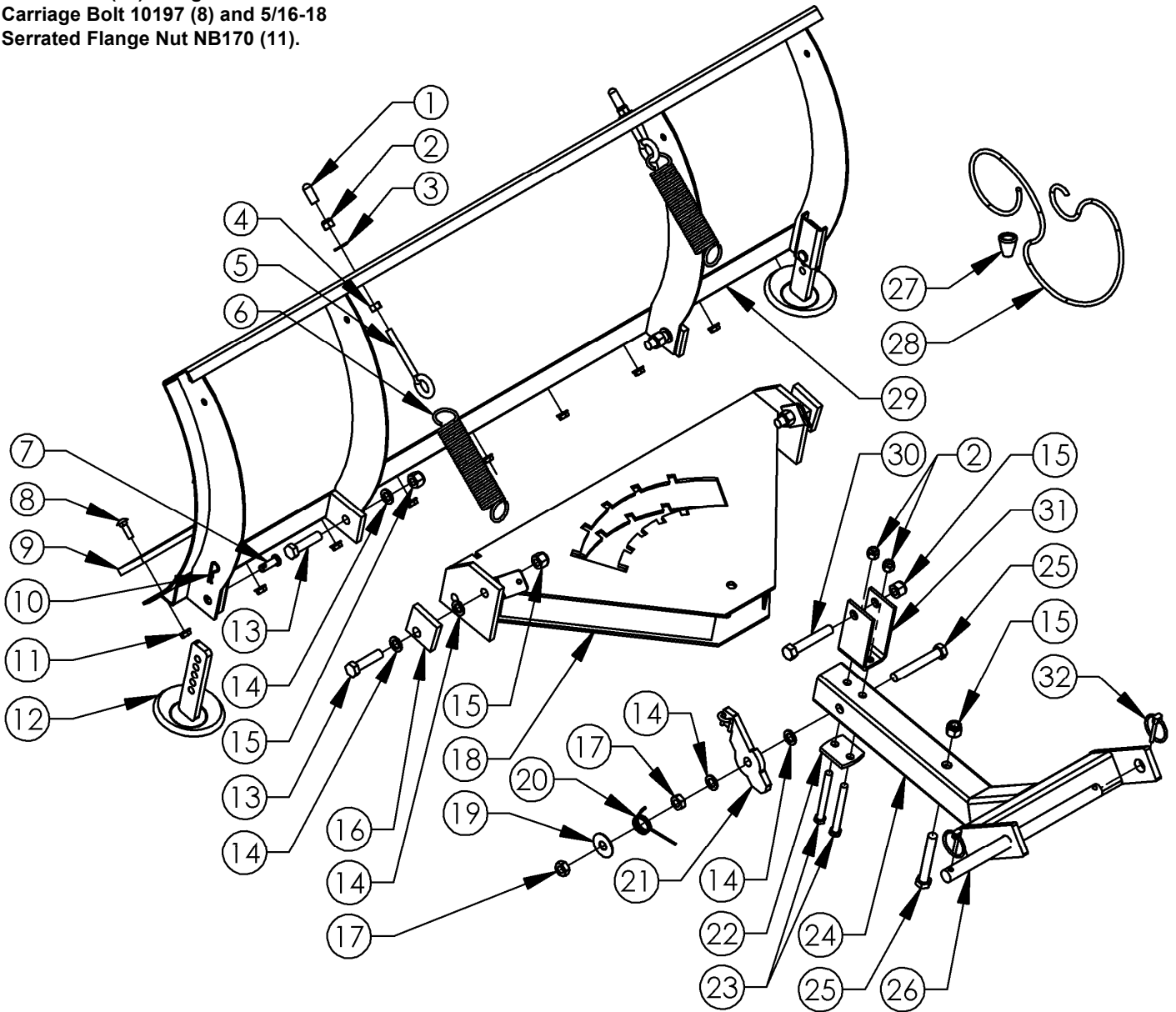

Item #	Part #	Description	Item #	Part #	Description
1	AS125	Cap - Round Vinyl, Black	17	NB121	Nut - Jam Lock, 1/2-13 2-Way
2	NB182	Nut - Nyloc 3/8-16	18	2323*	Pivot - Weldment
3	NB272	Washer - SAE Flat 3/8	19	TR150W	Washer - .531 X 1 1/2 X .062
4	NB212	Nut - HNC, 3/8-16	20	2336	Spring - Pivot
5	NB635	Eyebolt - Turned 3/8-16 X 3	21	2319*	Latch - Lever Assembly
6	2335	Spring - Tilt	22	2310*	Bracket - Support; Plow
7	NB300	Pin - Clevis, 3/8 X 1 1/8	23	NB150	Bolt - 3/8-16 X 3 HCC
8	10197	Bolt - Carriage 5/16-18 X 1	24	2588*	Mount - Plow Weldment
9	20084*	Edge - Cut, Reversible .375 X 2.5 X 50	25	NB577	Bolt - 1/2-13 X 3 1/2
10	NB127	Pin - Hair, #39	26	2642*	Pin - Plow Mount, 3/4 X 12
11	NB170	Nut - Serrated Flange 5/16-18	27	H7K	Knob - Rope
12	10068*	Skid - Weldment	28	H9B	Rope - Red
13	NB509	Bolt - 1/2-13 X 2 HCC	29	2150*	Blade - Rolled Weldment, 50
14	NB177	Washer - Mach 1/2	30	NB131	Bolt - 1/2-13 X 3 HCC
15	NB281	Nut - Nyloc 1/2-13	31	2327*	Bracket - Lift Assembly
16	2331*	Block - Tilt	32	NB506	Pin - Lynch, 3/16

When ordering replacement parts

*USE PAINT CODE: GT=GREY TK=BLACK



TO ENSURE PROPER ASSEMBLY, CAREFULLY FOLLOW ALL INSTRUCTIONS LISTED BELOW

Pivot Latch Assembly

These steps need to be done in sequence:

1. Lay parts down in the order they are shown below.
2. Slide Plow Mount 2588 (24) into Pivot Weldment 2323 (18) and secure with $\frac{1}{2}$ -13 X $3\frac{1}{2}$ Bolt NB577 (25) and $\frac{1}{2}$ -13 Nyloc Nut NB281 (15). Do not overtighten; the Plow Mount must be able to pivot freely.
3. Assemble the Pivot Latch assembly in the order shown below. The Pivot Latch assembly consists of the following components and is assembled in the following order: $\frac{1}{2}$ -13 X $3\frac{1}{2}$ Bolt NB577 (25), Plow Mount 2588 (24), $\frac{1}{2}$ Washer NB177 (14), Lever Latch 2319 (21), $\frac{1}{2}$ Washer NB177 (14), $\frac{1}{2}$ -13 Lock Nut NB121 (17), Pivot Spring 2336 (20), $1\frac{1}{2}$ Washer TR150W (19), and Lock Nut NB121 (17). Make sure the tail of the pivot spring is secured into the bent metal loop on the Plow Mount. Do not overtighten; the Lever Latch should be able to pivot freely after being assembled.
4. Attach Plow Support Bracket 2310 (22) and Lift Bracket 2327 (31) to Plow Mount 2588 (24) as shown using two NB150 3/8-16 X 3 Bolts (23) and two NB182 3/8-16 Nyloc Nuts (2).
5. Insert $\frac{1}{2}$ -13 X 3 Bolt NB131 (30) into Lift Bracket 2327 (31) and secure with $\frac{1}{2}$ -13 Nyloc Nut NB281 (15). Do not overtighten as this can bend the Lift Bracket. This is where you will attach your winch or manual lift pulley, sold separately.

The numbers in parenthesis on this page refer to items from the table on page 6.

Tie Red Rope H9B (28) to this loop. Attach Rope Knob H7K (27) to the other end of the Rope.

Part of Pivot Weldment 2323 has been hidden for clarity.

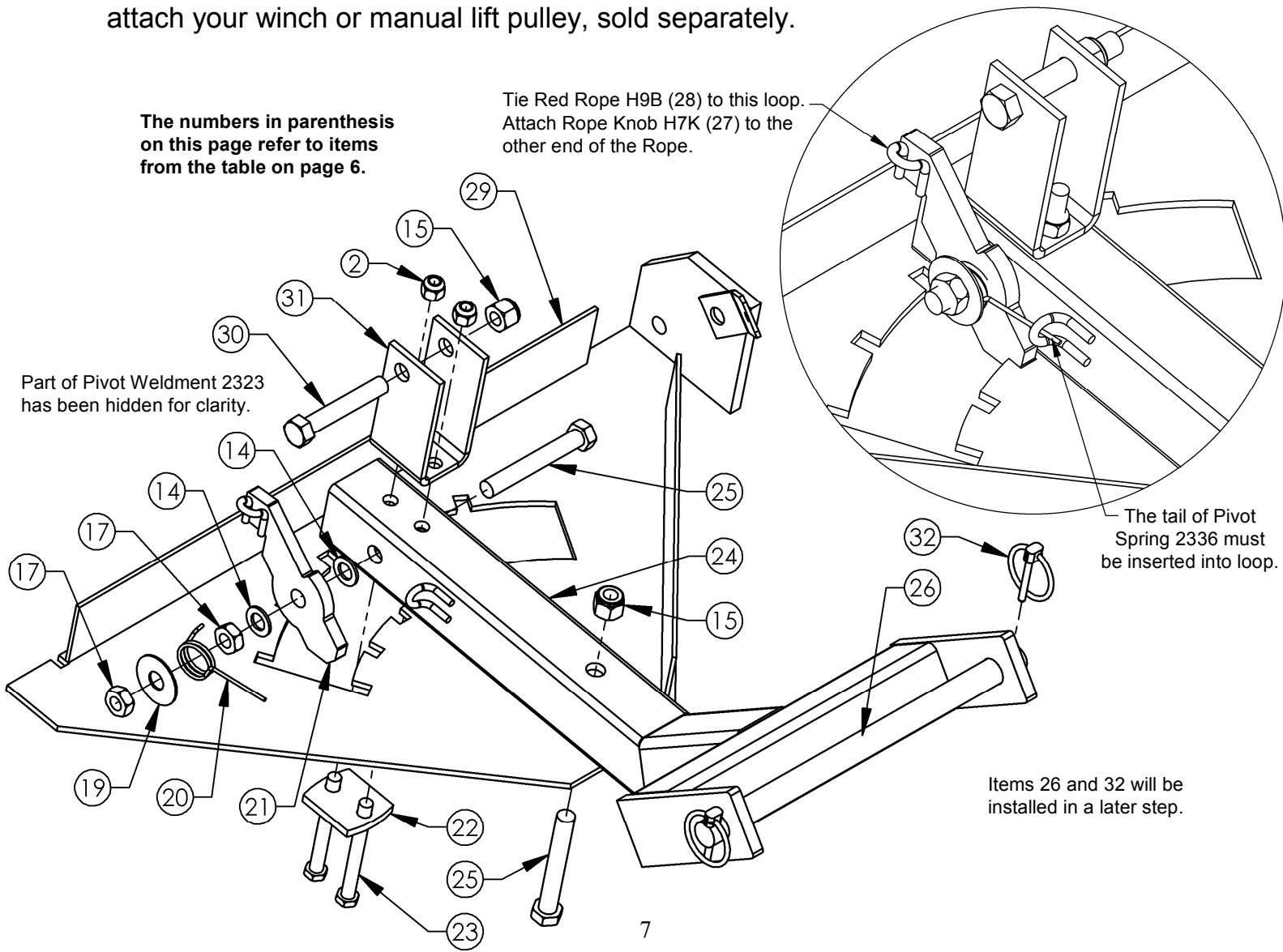

The tail of Pivot Spring 2336 must be inserted into loop.

Items 26 and 32 will be installed in a later step.



TO ENSURE PROPER ASSEMBLY, CAREFULLY FOLLOW ALL INSTRUCTIONS LISTED BELOW

Pivot Mount Assembly

1. Connect Skid Weldment 10068 (12) through the channel on the outer right edge of the Blade using Clevis Pin NB300 (7) and Hair Pin NB127 (10) in the order shown below. Repeat for the left side. The height can be adjusted using the holes in the Skid Weldment leg.
2. Assemble the Pivot Mount assembly to the Blade using $\frac{1}{2}$ -13 X 2 Bolt NB509 (13), $\frac{1}{2}$ Washer NB177 (14) and $\frac{1}{2}$ -13 Nyloc Nut NB281 (15) in the order shown below. It is important to ensure the $\frac{1}{2}$ Washer (19) is installed between the Blade and Pivot Mount assembly to allow for the correct rotation of the pivot. Repeat for the other side of the Pivot Mount. Do not overtighten; the Blade should be able to pivot freely after being assembled to the Pivot Mount.
3. Assemble the Tilt Block (16) to the left side of the Pivot Mount assembly using $\frac{1}{2}$ -13 X 2 Bolt NB509 (13), two NB177 $\frac{1}{2}$ Washers (14) and $\frac{1}{2}$ -13 Nyloc Nut NB281 (15). Repeat for the right side of the Pivot Mount assembly. The Tilt Blocks (16) set the vertical "tilt" or rake of the Blade.

The numbers in parenthesis on this page refer to items from the table on page 6.

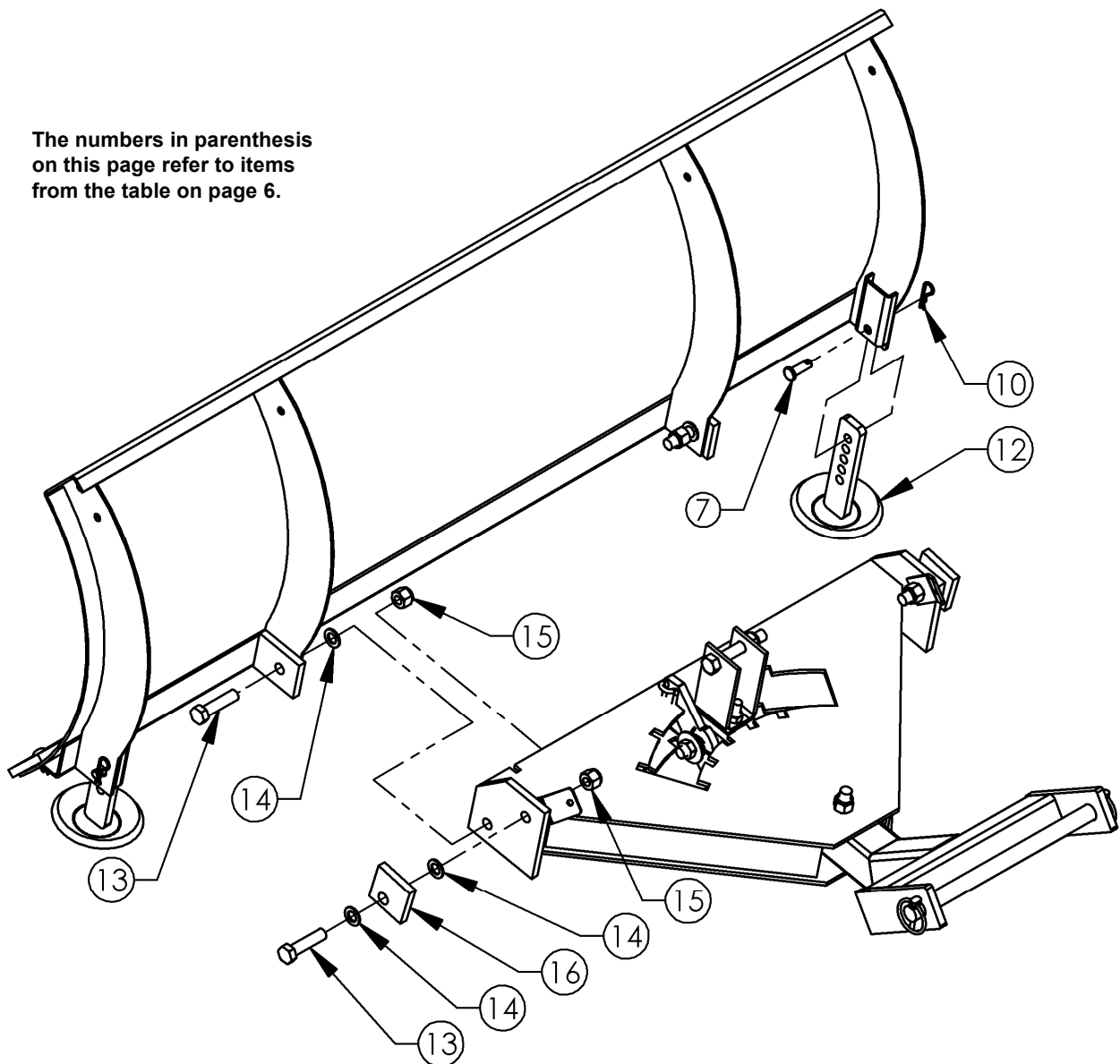



TO ENSURE PROPER ASSEMBLY, CAREFULLY FOLLOW ALL INSTRUCTIONS LISTED BELOW

Tilt Spring Assembly

1. Assemble one 3/8-16 Nut NB212 (4) to each Eyebolt NB635 (5).
2. Attach one end of Tilt Spring 2335 (6) to the Plow Mount assembly tab and the other end to Eyebolt NB635 (5).
3. Assemble Eyebolt NB635 (5) into the hole at the top of the Blade. Secure with 3/8 Washer NB272 (3) and 3/8-16 Nut NB182 (2). Place Vinyl Caps AS125 (1) over the remaining threads of the Eyebolt. Repeat for the other side.

The numbers in parenthesis on this page refer to items from the table on page 6.

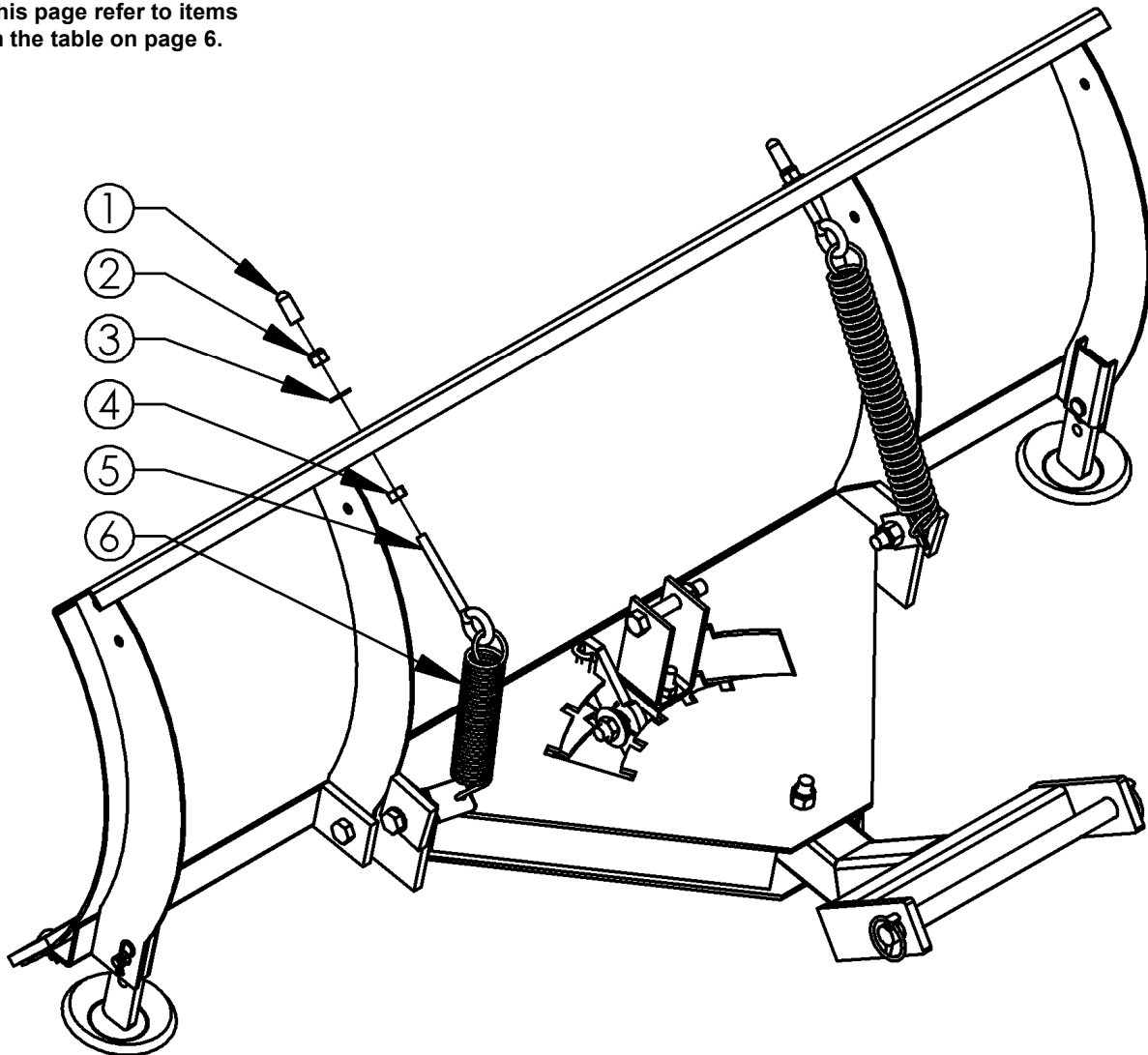



TO ENSURE PROPER ASSEMBLY, CAREFULLY FOLLOW ALL INSTRUCTIONS LISTED BELOW

Connecting the Blade to the Universal Mount

1. Connect the Blade Assembly to the Universal Mount Assembly by lining up the holes in Plow mount Weldment 2588 (24) with the holes in Slide Bar Weldment 20086 (16, pg 4).
2. Insert Plow Mount Pin 2642 (26) through holes and secure with Pin NB506 (32).

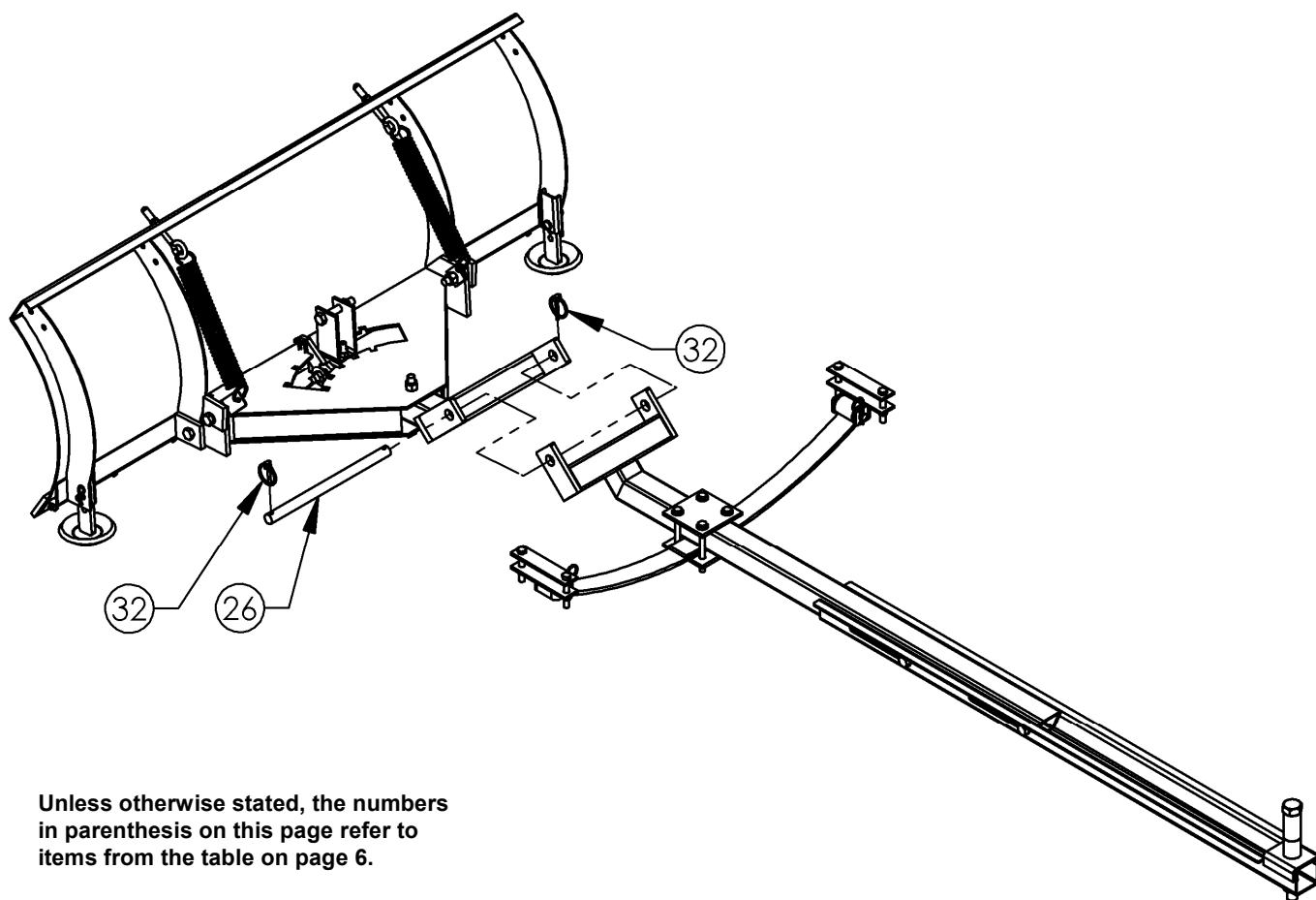

Unless otherwise stated, the numbers in parenthesis on this page refer to items from the table on page 6.

Plow Adjustment & Operation

The tension placed on Tilt Springs 2335 (6) determine the amount of pressure that must be applied to the Blade before it folds over if an obstruction is hit.

Tilt Springs 2335 (6) can be adjusted by turning 3/8-16 Nyloc Nut NB182 (2) on the Eyebolts NB635 (5), making adjustments until the Blade does not fold over during normal operation but does fold over if an obstruction is hit. Turn the nut clockwise to tighten the spring and counterclockwise to loosen the spring. Once the desired tension is achieved, lock the position of Eyebolt NB635 (5) using 3/8-16 Nut NB212 (4).

To change the Blade angle while operating, come to a stop, turn off the ignition and set the parking brake. Disengage Lever Latch 2319 (21) by pulling the Red Rope H9B (28) and rotate the Blade to the desired angle. Engage Lever Latch 2319 (21) making sure it is secured into one of the latch positions of Pivot Weldment 2323 (18).

NOTES



CHANGING YOUR LANDSCAPE SINCE 1945

swisherinc.com

OWNER'S MANUAL

19975

Starting Serial #: L215-001001

Commercial Pro

Plow Combo, 50" ATV

WHEN ORDERING PARTS, PLEASE HAVE THE
FOLLOWING INFORMATION AVAILABLE:

- * PRODUCT - _____
- * SERIAL NUMBER - _____
- * MODEL NUMBER - _____
TYPE - _____
- * PART NUMBER WITH PAINT CODE
* PART DESCRIPTION

TELEPHONE - 1-800-222-8183

FAX - 1-660-747-8650

SWISHER
1602 CORPORATE DRIVE, WARRENSBURG, MISSOURI 64093
PHONE 660-747-8183 FAX 660-747-8650

Made In The
USA
of US and Global Parts