

LIMITED WARRANTY - RESIDENTIAL SUMP PUMPS:

Decko Products warrants that the products specified in this warranty are free from defects in material or workmanship for three years from date of purchase. During the time period and subject to the terms and conditions, Decko Products will repair or replace to the original user or consumer any portion of this product which proves to be defective due to materials or workmanship. At all times Decko Products shall have and possess the sole right and option to determine whether to repair or replace defective equipment, parts, or components. Decko Products has the option to inspect any product returned under warranty to confirm that the warranty applies before repair or replacement under warranty is approved. This warranty sets forth Decko Products sole obligation and purchaser's exclusive remedy for defective product. Return defective product to the place of purchase or postpaid to Decko Products, Attn: Warranty Dept, 2805 Fairview Ave. North, Roseville, MN 55113 for warranty consideration.

WARRANTY PERIOD - PRODUCTS:

If, within the duration of product use by the original user, this product proves to be defective due to materials or workmanship, the product shall be repaired or replaced at Decko Products option, subject to the terms and conditions set forth in this warranty statement. Proof of purchase is required for warranty consideration. In the absence of suitable proof of the purchase date, the effective period of this warranty is 12 months from the product's date of manufacture.

LABOR, ETC. COSTS:

Decko Products shall IN NO EVENT be responsible or liable for the cost of field labor or other charges incurred by any customer in removing and/or affixing any product, part, or component thereof.

PRODUCT IMPROVEMENTS:

Decko Products reserves the right to change or improve its products or any portions thereof without being obligated to provide such a change or improvement for units sold and/or shipped prior to such change or improvement.

GENERAL TERMS AND CONDITIONS:

This warranty shall not apply to damage due to acts of God, normal wear and tear, normal maintenance services and the parts used in connection with such service, lightning or conditions beyond the control of Decko Products, nor shall it apply to products which, in the sole judgment of Decko Products, have been subject to negligence, abuse, accident, misapplication, tampering, alteration; nor due to improper installation, operation, maintenance or storage; nor to excess of recommended maximums as set forth in the instructions. Warranty will be VOID if any of the following conditions are found:

1. Product is used for purposes other than those for which it was designed and manufactured
2. Product not installed in accordance with applicable codes, ordinances, and good trade practices
3. Product connected to voltage other than indicated on nameplate
4. Pump exposed to but not limited to the following: sand, gravel, cement, grease, plaster, mud, tar, oil, gasoline, solvents or other abrasive or corrosive substances
5. Pump has been used for pumping liquids above 140°F
6. Pump allowed to operate dry (liquid supply cut off)
7. Sealed motor housing opened or product dismantled by customer

DISCLAIMER:

Any oral statements about the product made by the seller, Decko Products, the representatives, or any other parties do not constitute warranties, shall not be relied upon by the user, and are not part of the contract for sale. Seller's and Decko Products only obligation, and buyer's only remedy, shall be the replacement and/or repair by Decko Products of the product as described above. NEITHER SELLER NOR DECKO PRODUCTS SHALL BE LIABLE FOR ANY INJURY, LOSS OR DAMAGE, DIRECT, INCIDENTAL OR CONSEQUENTIAL (INCLUDING, BUT NOT LIMITED TO, INCIDENTAL OR CONSEQUENTIAL DAMAGES FOR LOST PROFITS, LOST SALES, INJURY TO PERSON OR PROPERTY, OR ANY OTHER INCIDENTAL OR CONSEQUENTIAL LOSS), ARISING OUT OF THE USE OR THE INABILITY TO USE THE PRODUCT, AND THE USER AGREES THAT NO OTHER REMEDY SHALL BE AVAILABLE TO IT. Before using, the user shall determine the suitability of the product for his/her intended use, and user assumes all risk and liability whatsoever in connection therewith.

THE WARRANTY AND REMEDY DESCRIBED IN THIS LIMITED WARRANTY IS AN EXCLUSIVE WARRANTY AND REMEDY AND IS IN LIEU OF ANY OTHER WARRANTY OR REMEDY, EXPRESSED OR IMPLIED, WHICH OTHER WARRANTIES AND REMEDIES ARE HEREBY EXPRESSLY EXCLUDED, INCLUDING BUT NOT LIMITED TO ANY IMPLIED WARRANTY OF MERCHANTABILITY OR FITNESS FOR A PARTICULAR PURPOSE, TO THE EXTENT EITHER APPLIES TO A PRODUCT SHALL BE LIMITED IN DURATION TO THE PERIODS OF THE EXPRESSED WARRANTIES GIVEN ABOVE.

Some states and countries do not allow the exclusion or limitations on how long an implied warranty lasts or the exclusion or limitation of incidental or consequential damages, so the above exclusion or limitations may not apply to you. This warranty gives you specific legal rights, and you may also have other rights which vary from state to state.



Revised 1305



OWNER'S MANUAL

INSTALLATION AND OPERATION INSTRUCTIONS FOR SUBMERSIBLE SUMP/EFFLUENT PUMP

Model:

92581, 92571

92731, 92751



If for any reason you have questions concerning your new Superior Pump, call us toll free at 1-800-495-9278.

Carefully read and understand all of the Warnings and installation instructions in this manual. Failure to follow these instructions could lead to serious bodily injury and/or property damage. Retain these instructions for future reference.

This pump has been manufactured with your needs in mind. Properly installed in the right application, your new Superior Pump will give you years of carefree performance.

⚠ DANGER !

Water and electricity can be dangerous if certain precautions are not adhered to. This pump is designed to operate perfectly safe in a water environment; however, improper use and installation can result in personal harm from electrical shock. Please pay attention to the following warnings.

⚠ WARNING !

Never touch any electrical device, including this pump, when it is touching water, in water, or even in a moist environment. Always unplug (disconnect the electricity) when working on or installing the unit.

⚠ WARNING !

RISK OF ELECTRICAL SHOCK. This pump is supplied with a grounding conductor and grounding-type attachment plug. To reduce the risk of electrical shock, be certain that it is connected only to a properly grounded, grounding-type receptacle.

⚠ WARNING !

Do not use the power cord or discharge hose to carry or handle the pump. Doing so may cause damage to the power cord or discharge hose. Use the carrying handle supplied with the pump.

⚠ WARNING !

Always use a grounded outlet. A three-prong mating type receptacle is needed for safe use. This should be in accordance with the National Electric Code and any additional codes or laws required by your local government.

⚠ NOTICE !

It is strongly recommended to use a ground fault interrupt device on any electrical appliance, including this pump, when used in a wet or moist environment. This is required by many local codes and enforcement agencies. It is strongly recommended by Superior Pump as it provides a much safer installation and will greatly reduce possible injury from electrical shock.

REPLACEMENT PARTS
To order replacement parts call

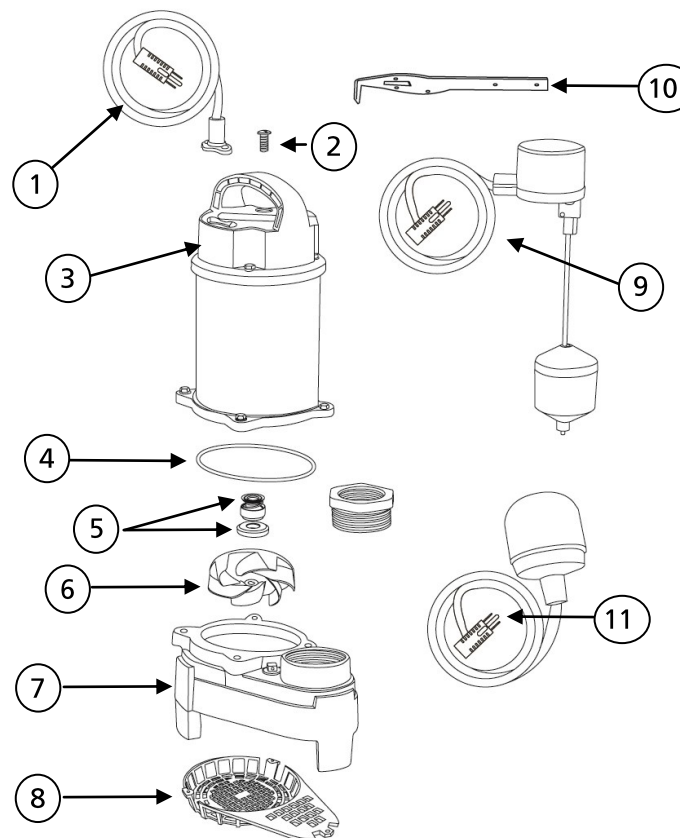

Ref#	Description	Part #
1	Power Cord	99102
2	Oil Fill Plug with O-ring	99056
3	Gasket	99162
4	Shaft Seal	99157
5	Impeller	99152
6	Volute/Base	99165
7	Intake Screen	99163
8	Float Switch	92010
9	Vertical float Switch Bracket	99104
10	2" MNPT x 1-1/2" MNPT Adapter	99250
11	Tethered Float Switch	92000

NOTICE ! Height and/or piping restriction will reduce the pump output performance. See the performance chart below to insure you have the proper pump for your application. Whenever possible use the same size or larger pipe as the pump discharge for optimum performance. Reducing the pipe size will not harm your pump; it will just reduce the output.

PERFORMANCES

Model #	Output in gallons per minute at listed discharge									
	Height above pumping level									
	0'	5'	10'	15'	20'	25'	30'	35'	40'	45'
92581 92571	75	70	64	57	49	40	31	21	11	0
92731 92751	80	75	69	61	55	45	38	25	16	2

SPECIFICATIONS

Power supply requirements.....	120V, 60 Hz
92581, 92571 Motor.....	1/2 HP, Continuous Duty, Split Capacitor
92731, 92751 Motor.....	3/4 HP, Continuous Duty, Split Capacitor Thermally Protected
Amps.....	7.5
Liquid Temperature Range.....	32° F - 120° F (0° C - 49° C)
Circuit Requirements.....	15 amp minimum
Solids Handling.....	1/2"
Discharge Size.....	2" NPT
Warranty.....	3 Years

 DANGER !

Do not use this pump to pump chemicals, flammable liquids, sewage or corrosive liquids. You could injure yourself and the pump will fail. Pumping these types of liquids voids the warranty. Superior Pump and other pump companies manufacture pumps for these types of liquids. Make sure you purchase a pump designed for your specific needs. This pump will handle fluids with the same characteristics as water. If you have any questions call us at 1-800-495-9278.

 WARNING !

Your pump has thermal over-load protection built in. It is not recommended for pumping liquids over 120° F. The thermal overload protector will automatically shut down the pump in an overheat situation. It will then reset itself once the pump cools down. This overload is designed as a safety device and it will fail after repeated use. Normal operation is for fluids between 32° F & 120° F.

 WARNING !

DO NOT RUN THE PUMP DRY. The pump depends on water for cooling and lubrication. Operating the pump without water may cause the motor to overheat or cause damage to parts of the pump. It may also shorten the life of your pump.

 NOTICE !

EXTENSION CORDS

For best performance, it is recommended to connect the power cord directly to the grounded GFCI outlet. If the use of an extension cord is necessary, always use a grounded waterproof type cord. Never use longer than a 25-ft. cord that is lighter than 14/3 gauge.

 DANGER !

Keep all electrical connections away from wet and moist environments. Wet connections can cause electrical shock resulting in personal injury.

USE AND INSTALLATION

⚠️ WARNING !

Always disconnect the power source before attempting to install, service or perform maintenance on the pump. Failure to do so may result in fatal electrical shock. Always disconnect the power source before servicing pump.

Your Superior Pump is designed and built to give you reliable performance and long life. It will pump water automatically for years when properly installed in the right environment.

REMOVING OLD PUMP. (If necessary)

1. Make sure power supply is disconnected.
2. After the power is off, remove the old pump. There are many different possible types of installations. It is best to remove all old piping and start over with new piping. Be sure to clean all debris and dirt out of the sump basin before installing your new pump. Be sure to have a grounded 120V AC outlet mounted within 6 ft. of your sump basin. Again, it is highly recommended that a GFCI (ground fault circuit interrupter) outlet be installed in the receptacle box.

⚠️ NOTICE !

A qualified electrician must perform all wiring.

INSTALLATION (New Pump)

1. Set your new pump in the bottom of the sump basin off to one side. The pump should be placed on a solid foundation. Do not place the pump directly on the ground or sandy or rocky surfaces. Sand and small stones may clog or cause damage to your pump.
2. Make sure the float switch will swing freely from the bottom to top without coming in contact with the side of the sump basin. Contact with the side of the sump basin may cause the switch to malfunction. See figure below.
3. It is highly recommended to install a full flow, swing type check valve (not included) as close to the discharge outlet on the pump as possible. A new check valve will greatly increase the life of your pump. The check valve should be the same size as the pump discharge.

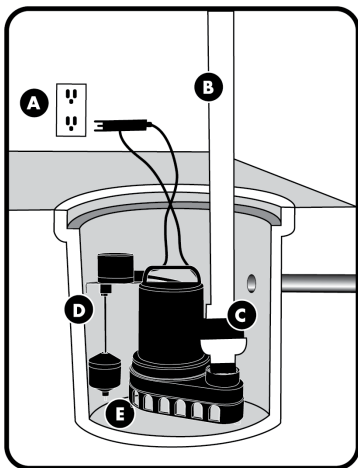

- A. Grounded Outlet. A GFCI outlet is strongly recommended.
- B. Discharge Pipe
- C. Full-flow swing type check valve
- D. Sump Basin
- E. Position pump so the float switch operates freely without touching the sides of the basin.

4. Connect the pump and check valve together using schedule 40 PVC pipe and fittings. You can also use DWV or ABS pipe, as this is not a pressure installation. Corrugated drain hose is intended for temporary use and should not be used in a permanent installation. Although there are many types of pipe that work adequately for this installation, PVC is recommended.
5. Test your installation after you have completed setting up the pump. Plug the cord from the pump into the piggyback plug of the float switch, then plug that into your grounded outlet. The pump should not run at this point. If the pump runs, the switch is stuck in the upright position or the pump is plugged directly into the outlet and not through the piggyback switch plug. Fill the sump basin with water using buckets or a hose. When the switch floats to the upright position, the pump will turn on. The switch will turn off the pump when it reaches the down position. You may adjust the switch to meet your particular needs. Remember the switch must swing freely without touching the sides of the sump basin.

NOTE: This pump has a built in anti-airlock device. Leakage is normal from this device.

TROUBLESHOOTING		
PROBLEM	POSSIBLE CAUSES	HOW TO CORRECT
If the pump does not start or run	Pump is not plugged in, switch or breaker is off	Plug pump in or turn on switch/breaker
	Check for blown fuses or tripped circuit breakers or tripped GFCI outlets	Replace fuse, reset breaker, reset GFCI outlet
	Float switch is defective	Check and replace if necessary
	Motor thermal protector tripped	Allow pump to cool. Pump will reset
	Float switch is stuck or obstructed	Remove obstruction or position pump so it will not become stuck
The pump starts and stops too often	Backflow of water from discharge hose/pipe	Install or replace check valve
	Float switch is defective	Replace float switch
If the pump runs but moves little or no water	Clogged intake screen	Clean or replace screen
	Clogged discharge hose/pipe	Remove clog
	Frozen discharge hose/pipe	Allow hose/pipe to thaw
	Pump is air locked	Clean out airlock hole with a paper clip or pipe cleaner
	Low line voltage	Check wire size and increase if necessary
	Check valve is stuck in the closed position	Inspect, repair or replace if necessary
	Check valve is installed backwards	Make sure valve is installed in the correct direction of flow
	Worn, damaged or clogged pump parts	Inspect for wear, damage or clog and clean or replace if necessary
Discharge head exceeds pump capacity	If pumping height is over 25', the pump will not move water. See performance chart	
Pump does not shut off	Float switch is obstructed or stuck	Remove obstruction
	Defective Float Switch	Replace switch