

PARTS INCLUDED

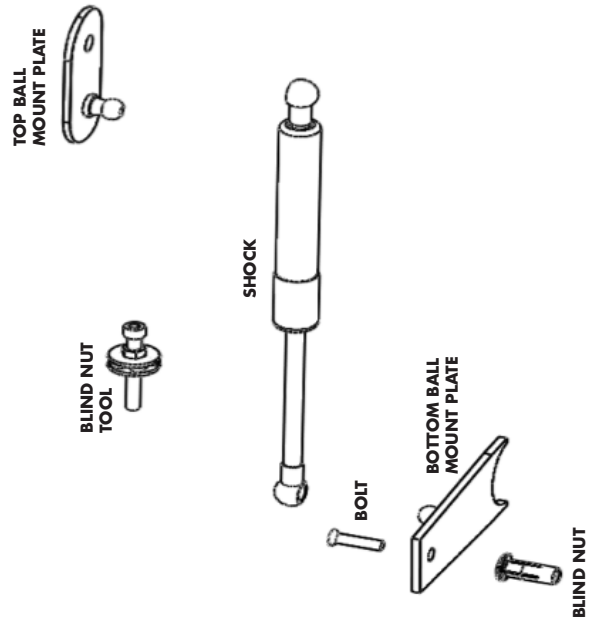

PARTS LIST

SHOCK	1
TOP BALL MOUNT PLATE	1
BOTTOM BALL MOUNT PLATE	1
BLIND NUT TOOL	1
BLIND NUT/NUTSERT	1
MYLAR	1

TOOLS REQUIRED:

- 10MM WRENCH
- 13MM WRENCH
- M4 ALLEN WRENCH/SOCKET
- M5 ALLEN WRENCH
- TAPE MEASURE
- PLIERS

STEP 1

*** NOTE: THIS PRODUCT CAN ONLY BE INSTALLED ON THE DRIVER'S SIDE.**

Using a M5 Allen wrench and a 10mm wrench, install the blind nut in the opening by the tailgate pivot point. The nutsert should be tightened at least nine 360 degree turns. Mark one side of the nut and count the number of revolutions to insure the correct number of turns. After the nine turns, if the blind nut can still be moved or rotates, continue tightening an additional 1 - 2 turns. Re-check blind nut, repeat as needed.

Remove the nutsert tool when installation is complete.

WARNING: Overtightening the nutsert can strip the threads and cause the nutsert to be unusable.



STEP 2

Install the bottom ball mount plate by placing the bolt through the hole in the plate into the nutsert. Tighten with M4 allen. Torque to 8 ft-lbs.



STEP 3

Remove the tailgate cable and use a 13mm wrench/socket to remove the cable bolt.

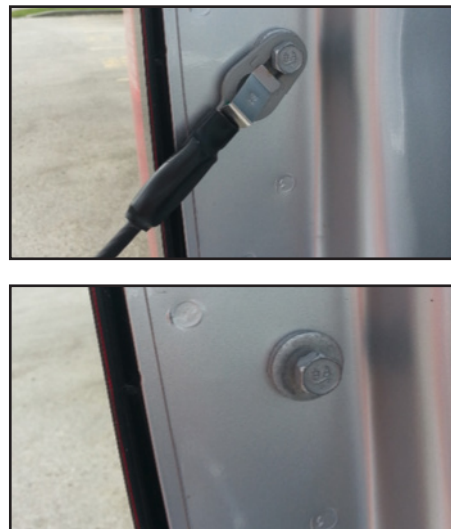

STEP 4

Using the bolt removed in the previous step, attach the top ball mount plate using a 13mm wrench/socket.

Hold the plate in place vertically when tightening as it will rotate if not held.



STEP 5

Re-attach the tailgate cable.



STEP 6

A Mylar sheet has been provided to help prevent components from rubbing against the truck bed and tailgate in the event that any part becomes loose. Using scissors, cut the mylar to the size needed. Apply the mylar to the truck bed and tailgate where tailgate assist components will be in close proximity during opening/closing. The red lines show the area where the mylar has been installed.



The vehicle shown is an example of how the mylar can be installed. Your vehicle may differ from the vehicle shown.



STEP 7

Install the larger part of the shock on the top ball mount.



Install the narrow end of the shock on the bottom ball platemount



*Periodically check the upper and lower mounting locations to insure that parts have not loosened through repeated use. If either mounting location is found to be loose, re-tighten the hardware as needed.

FAQ's

Can the Tailgate Assist be installed on the passenger's side?

No. The unit will not work on the passenger side of the truck bed. Installing the tailgate assist on the passenger side can cause the tailgate to come off the truck.

Are there installation videos?

Yes. All installation videos can be viewed at: www.deezee.com/tailgateassist

DEE ZEE, INC. WARRANTY COVERAGE

Dee Zee, Inc. guarantees the original purchaser a limited warranty against manufacturer defects in materials, workmanship, and design under normal use.

Tailgate Assist has a 3-year limited warranty. Operational and wear items such hardware have a one-year (1) warranty. To read the complete warranty policy for your product visit: www.deezee.com/warranty

Buyer assumes all risk, liability, and cost for the installation and use of Dee Zee products. Dee Zee, Inc. assumes no liability for injury, loss, incidental or consequential damages in the event of an accident.

WARRANTY & RETURN SUBMISSION PROCEDURE

Please contact the original point of purchase for: shipping damage, returns, or warranty claims. Contact Dee Zee directly for missing parts or hardware.

All warranty claims will be initiated at the place of purchase. The original purchaser will be required to present the original sales receipt with purchase date shown and provide photographs of the defect.

DZ 43100 CHEVY TAILGATE ASSIST 2007-CURRENT



INSPECT YOUR PRODUCT FOR DAMAGE & MISSING PARTS BEFORE PROCEEDING TO INSTALLATION

1-800-779-2102

Mon – Thurs: 8:00am - 5:00pm | Friday: 8:00am - 4:00pm (CST)

WWW.DEEZEE.COM

**REGISTER YOUR PRODUCT ONLINE: www.deezee.com/registration
VIEW INSTRUCTIONS ONLINE: www.deezee.com/instructions**

⚠️ WARNING: Cancer and Reproductive Harm
www.P65Warnings.ca.gov