



1-800-779-2102

Mon – Thurs: 8:00am - 5:00pm | Friday: 8:00am - 4:00pm CST

**INSPECT YOUR PRODUCT FOR DAMAGE & MISSING
PARTS BEFORE PROCEEDING TO INSTALLATION**

PROCEDURE FOR RETURNS OR MISSING HARDWARE

-PLEASE CONTACT THE ORIGINAL POINT OF PURCHASE FOR:
SHIPPING DAMAGE, RETURNS, OR WARRANTY CLAIMS

-CONTACT DEE ZEE DIRECTLY FOR MISSING PARTS OR HARDWARE

WWW.DEEZEE.COM

REGISTER YOUR PRODUCT ONLINE: www.deezee.com/registration

VIEW INSTRUCTIONS ONLINE: www.deezee.com/instructions

⚠️ WARNING: Cancer and Reproductive Harm
www.P65Warnings.ca.gov

Operating, servicing, and maintaining a passenger vehicle can expose you to chemicals such as lead, phthalates, engine exhaust, and carbon monoxide that are known to the State of California cause cancer and birth defects or other reproductive harm. To minimize exposure, service your vehicle and its accessories in a well-vented area and wear gloves or wash your hands frequently.



DEE ZEE, INC. WARRANTY AGREEMENT

Dee Zee, Inc. guarantees the original purchaser a limited lifetime warranty against manufacturer defects in materials, workmanship, and design under normal use, excluding damage resulting from road hazards such as gravel or other debris, product misuse, improper installation, impairments from accidents, product modifications, improper repairs, spills, vandalism, product neglect, or acts of God.

This warranty applies only to the original purchaser of new product(s) and is limited to the replacement of genuine Dee Zee products. Modification of any kind to Dee Zee products voids all warranty coverage. Warranty does not include electrical components, installation, cost of removal, labor, transportation costs, loss of use, inconvenience, or consequential damages.

WARRANTY COVERAGE - MATERIALS & WORKMANSHIP

LIMITED LIFETIME WARRANTY:

- **STAINLESS STEEL:** Side Steps, Grill Guards, Bull Bars, Bed Caps, and Side Rails
- **ALUMINUM:** Side Steps, Running Boards, Storage Boxes, Transfer Tanks, Bed Protection, Side Rails, Invis-A-Racks, and Cab Racks
- **PLASTIC:** Storage Boxes
- **OTHER:** Front and Rear Bumpers

THREE-YEAR WARRANTY:

- **POWDER-COATED / E-COATED STEEL:** Side Steps, Running Boards, Storage Boxes, Transfer Tanks, Cab Racks, Sport Bar Ladder Racks, Cargo Carriers, Mounting Brackets (NX, Rough Step, and Bumper Guards only)
- **OTHER:** Tailgate Assist, Bed Mats, Floor Mats, Auxiliary Fuel Connection Kits, and All Products Not Otherwise Listed Individually

WARRANTY COVERAGE – FINISH PROTECTION

The finish of all Dee Zee products is covered for one-year (1) from the date of purchase. Dee Zee products have a high quality finish that must be cared for and maintained like any other exposed finish on the vehicle. Protect the finish with non-abrasive automotive wax (e.g. Pure Carnauba) on a regular basis. Applying soaps, polishes, or waxes that contain an abrasive compound may scratch the finish and leave the exposed material susceptible to corrosion.

WARRANTY COVERAGE – COMPONENT PARTS

Operational items such as shocks, latches, hinges, and wear items including, but not limited to, mud flaps, step pads, toolbox tray, end caps, hardware, seals, etc. have a one-year (1) warranty. Replacement component parts can be ordered via credit card (MasterCard or VISA) by calling 1-800-779-2102. All replacement parts are non-returnable and non-refundable.

GPI® FUEL PUMPS & ACCESSORIES

All Great Plains Industries (GPI) products, including transfer tank pumps and fuel meters are covered by GPI's warranty policies. Dee Zee's warranty terms do not apply to GPI products. To submit a warranty claim, please contact GPI at 1-800-835-0113 or visit www.gpi.net.

WARRANTY SUBMISSION PROCEDURE

All warranty claims will be initiated at the place of purchase. The original purchaser will be required to present the original sales receipt with purchase date shown and provide photographs of the defect.

In the event the originally purchased product style is no longer available, Dee Zee will warranty the defective part with a current equivalent. If a comparable product is no longer available, the product would be returned to the store of purchase for a refund or the applicable cost difference can be paid to choose an alternate style.

DISCLAIMER

All products are sold as appearance accessories and should not be relied upon as protection for the vehicle or its occupants in the event of an accident. Vehicles equipped with a supplemental restraints system (air bags) deployed by impact and collision avoidance systems should not be modified in any way. Always consult the vehicle manufacturer if you have any questions regarding supplemental restraint systems and sensors.

Buyer must accommodate front and rear sensors during product installation and assumes all risk should these be tampered, rerouted, severed, or disconnected. This includes disabling visual, audio, or vibration alerts into the cab. Buyer assumes all risk and responsibility for wiring any supplemental auxiliary lights.

Buyer assumes all risk, liability, and cost for the installation and use of Dee Zee products. Dee Zee, Inc. assumes no liability for injury, loss, incidental or consequential damages in the event of an accident.



Thank you for choosing Dee Zee to add function and accessorize your vehicle. Dee Zee has been a staple brand in the truck accessory market since 1977 and we hold a reputation of quality manufacturing based in America's Heartland. Our products are born through careful engineering and backed by industry leading warranty programs. We appreciate the opportunity to serve you and your vehicle!

Review the instruction pages in their entirety to prepare the required tools

Warning: Please check for wiring or other obstructions before drilling any holes in the vehicle. If it is necessary to drill any holes, Dee Zee recommends putting a sealant or rust inhibitory around all holes drilled into the body of the vehicle.

It is the sole responsibility of the vehicle owner to check for tire clearance. It is unlawful and dangerous to ride on any external vehicle step while the vehicle is in motion.

Cleaning: To be entitled to all warranty rights offered with the product, Dee Zee steps need to be cleaned regularly with a mild detergent. Do NOT use abrasive cleaners. For stainless steel products, the application of a high grade automotive wax is recommended.



Dee Zee Cares - Please Recycle

For an electronic version of these instructions visit: www.deezee.com/instructions

Register your product online: www.deezee.com/registration

NXc Running Board Installation Instructions

DZ 16224 (2015-Current) FORD EDGE

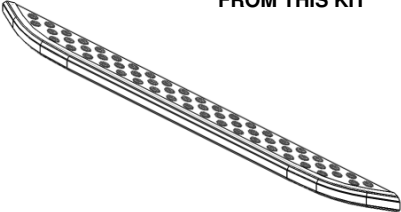
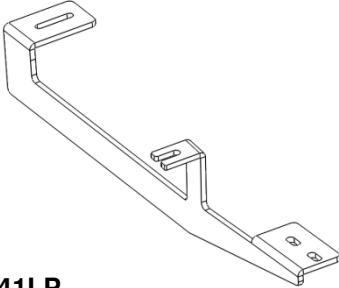
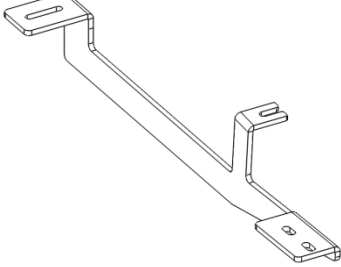
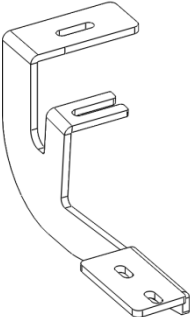
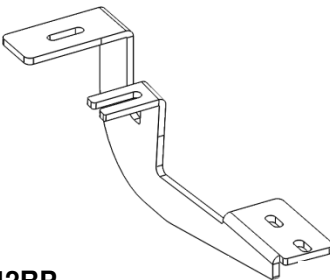
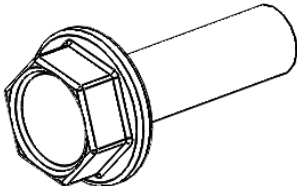
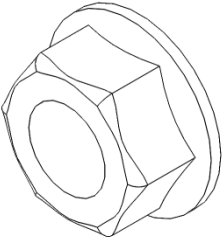
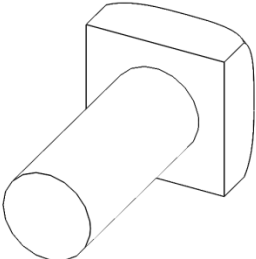
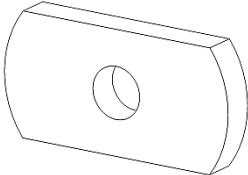
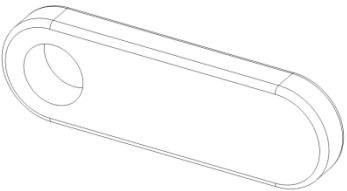
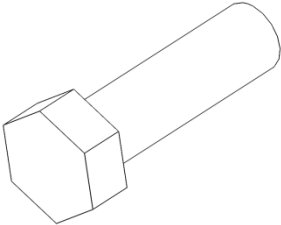
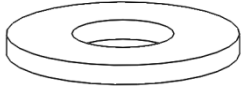
<p>A NXc Running Board *SOLD SEPARATELY FROM THIS KIT*</p>  <p>Various X2</p>	<p>B Driver Front Bracket</p>  <p>B 2341LP X1</p>	<p>C Passenger Front Bracket</p>  <p>B 2341RP X1</p>
<p>D Driver Rear Bracket</p>  <p>B 2342LP X1</p>	<p>E Passenger Rear Bracket</p>  <p>B 2342RP X1</p>	<p>F M8 X 25mm Hex Head Flange Bolt</p>  <p>PN 525 X4</p>
<p>G M8 Hex Head Flange Nut</p>  <p>PN 526 X8</p>	<p>H M8 X 18 mm Square Head Bolt</p>  <p>PN 524 X8</p>	<p>I 8mm Threaded Plate</p>  <p>PN 835 X4</p>
<p>J Offset Threaded Plate</p>  <p>PN 742 X4</p>	<p>K 3/8 X 1 1/4" Hex Head Bolt</p>  <p>PN 114B X4</p>	<p>L 3/8" Flat Washer</p>  <p>PN 113B X4</p>

<p>Tools Required:</p> <p>Needle Nose Pliers</p> <p>T30 Torque Bit</p>	 <p>Straight Blade Screwdriver</p>		<p>7/32"</p> <p>9/16"</p> <p>10mm</p> <p>13mm</p>
---	---	--	---

1

Place two 8mm square head bolts (H) into each of the two bolt channels of the running board (A) and slide toward either end of the board. For this application, there should be two bolts in each channel on opposite ends of the board.

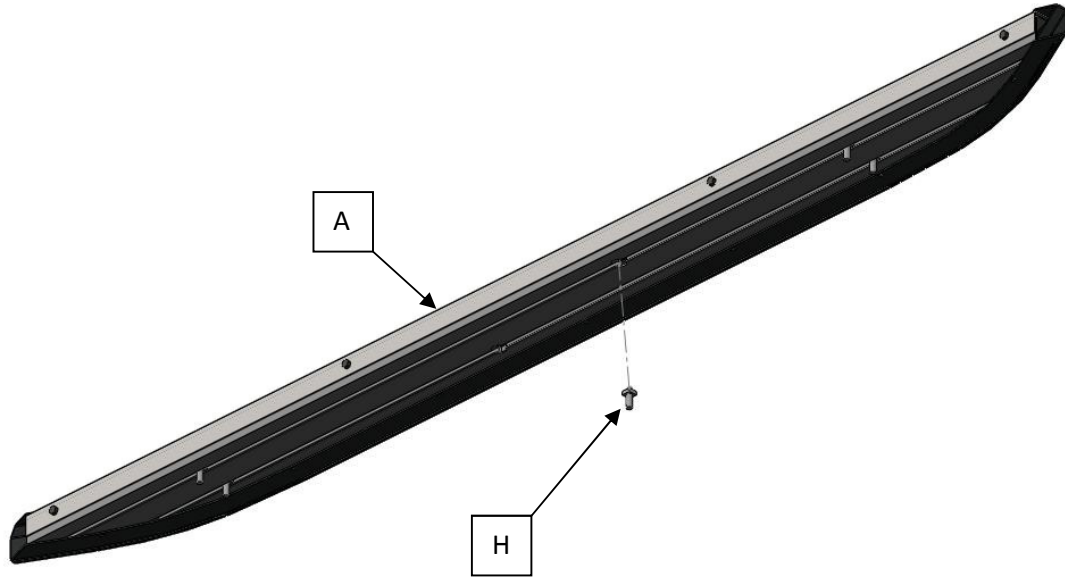

- 2** Remove the two plastic covers and the two fabric covers from under the vehicle. There will be a large fabric cover that runs most of the vehicle and then a smaller plastic cover in front of the rear wheel well, on each side of the vehicle. To remove the fabric cover, use a 10mm socket to remove the seven silver clip nuts, a T30 Torque bit to remove the two T30 bolts, a pair of needle nose pliers to pull down on the three tabs in the middle of the plastic covers, and a 7/32" socket to remove the two bolts located in the front wheel well. To remove the plastic cover, use a screw driver to remove the rear two clips and a T30 torque bit to remove two bolts. In order to install the brackets these covers will either have to be removed or cut.

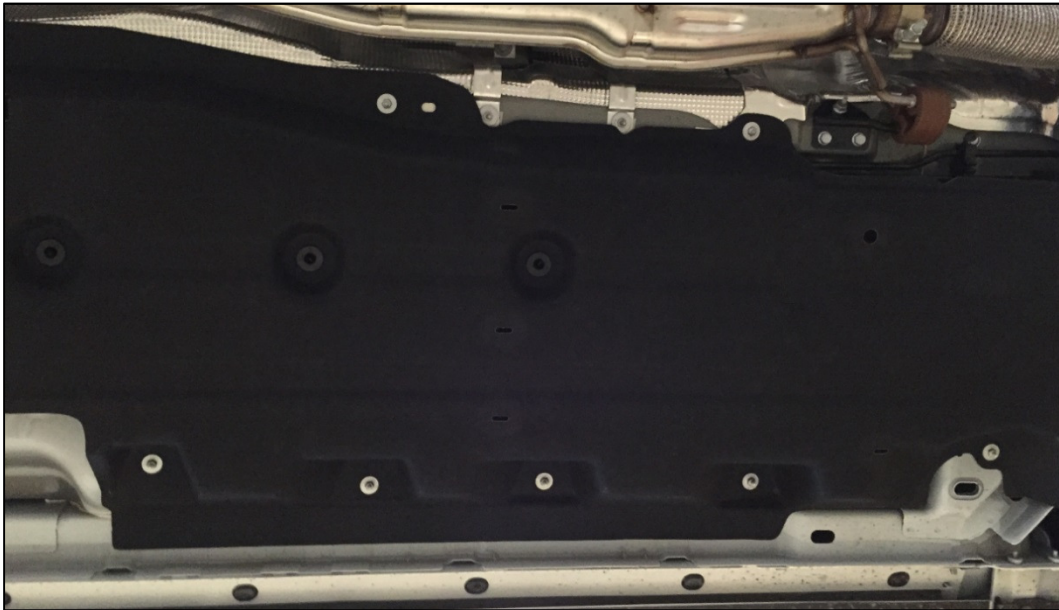

Front Driver's Fabric Cover



Rear Driver's Plastic Cover

- 3** Locate the existing hole locations shown below. There will be two sets of hole locations (Front, Rear).



Outer Mounting Location



Inner Mounting Location

Front Driver



Inner Mounting Location

Outer Mounting Location

Rear Driver

- 4** Using the 3/8" bolt (K), 3/8" washer (L), and offset threaded plate (J), thread the bolt through the hole in the front driver side brace (B).

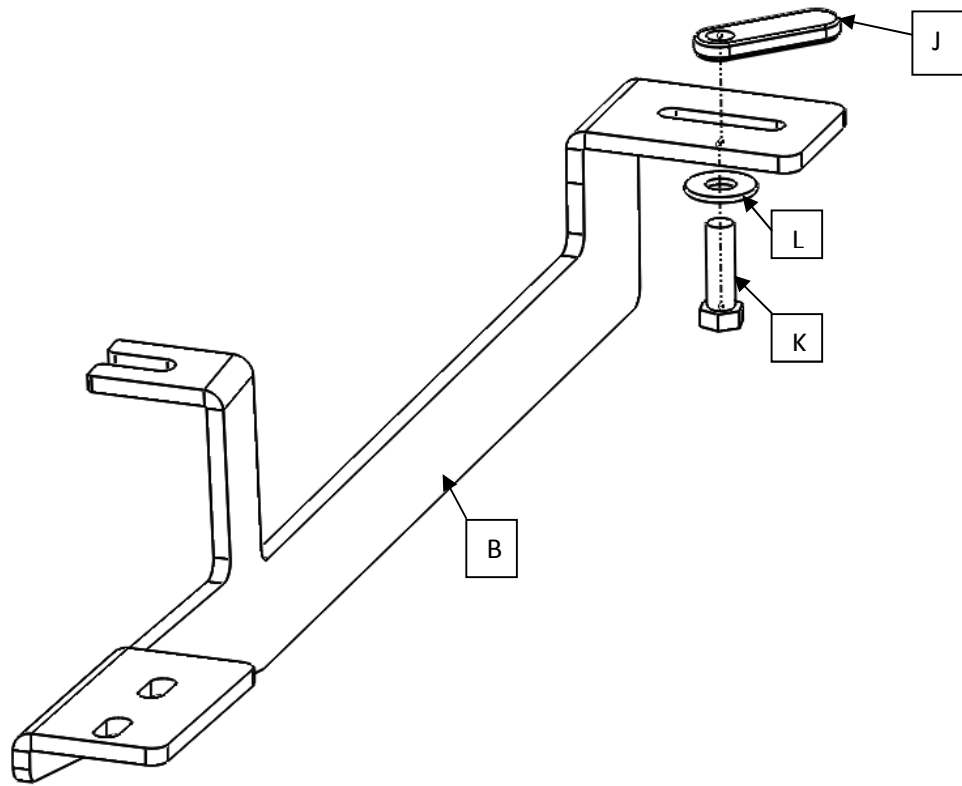

- 5** Using an 8mm bolt (F) and threaded plate (I), thread the bolt into the plate. Repeat this for each 8mm bolt (F) and threaded plate (I).

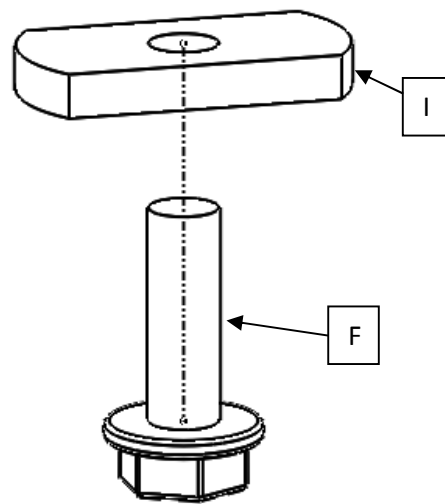

6 Insert the threaded plate (I) into the front outer mounting location



7 Insert the threaded plate that was installed to the inner mounting location on the vehicle.

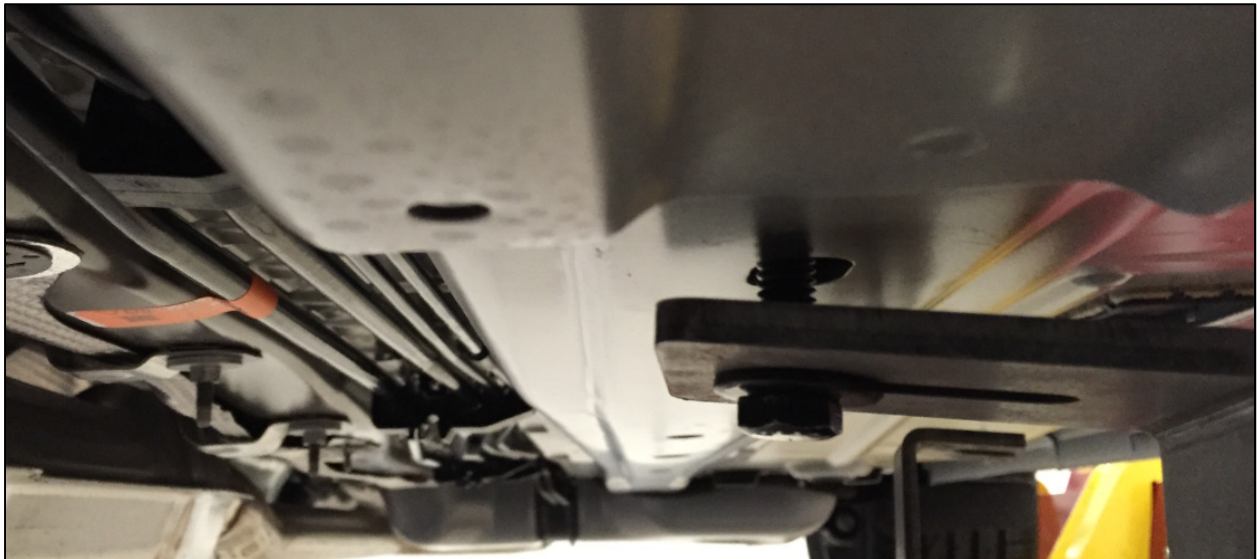

- 8** When the inner plate is in the vehicle, rotate the brace around and capture the bolt from the outer mounting location in the open ended slot.



- 9** Pull down on the brace to put the threaded plate under tension and tighten the inner mounting location with a 9/16" socket. Pull down on the brace to put the threaded plate under tension and tighten the outer mounting location with a 13mm socket.

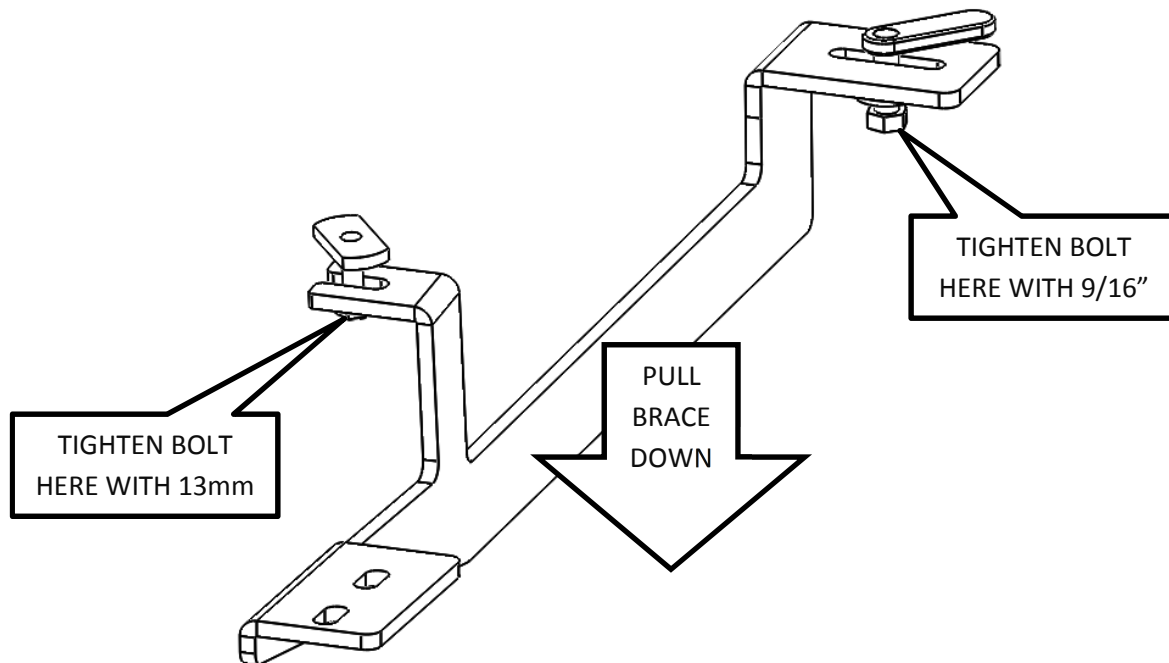

- 10** Using a 3/8" bolt (K), washer (L), and offset threaded plate (J), thread the bolt through the slot in the rear driver side brace (D).

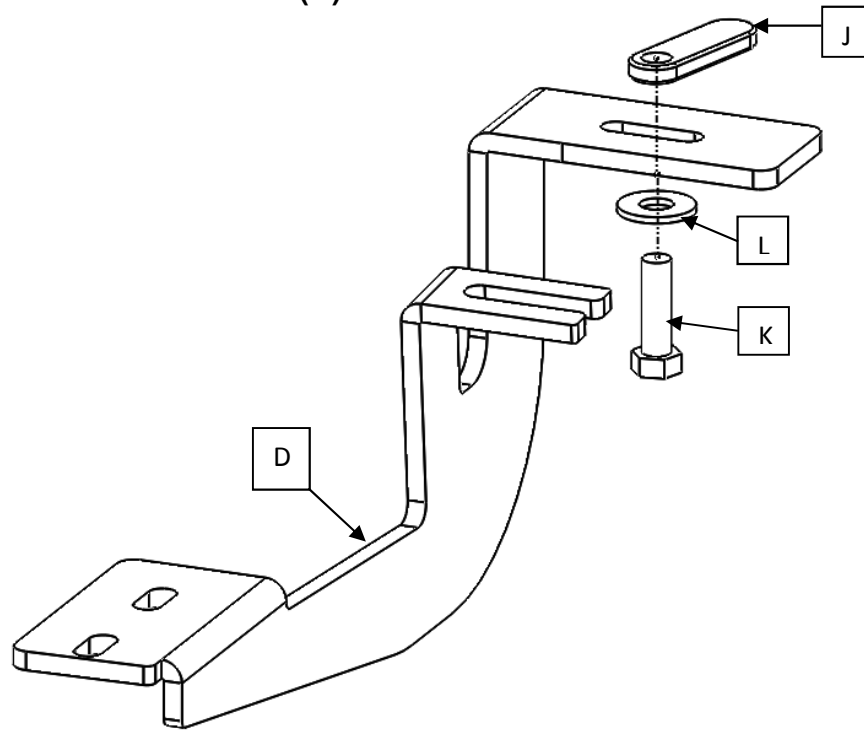

- 11** Insert a threaded plate (I), made in step 5, into the rear outer mounting location



- 12** Once the threaded plate is in the opening, insert the threaded plate that was installed to the inner mounting location on the rear brace into the inner mounting location on the vehicle.



- 13** When the threaded plate is in the vehicle, rotate the brace around and capture the bolt from the outer mounting location in the open ended slot.



- 14** Pull down on the brace to put the threaded plate under tension and tighten the inner mounting location with a 9/16" socket. Pull down on the brace to put the threaded plate under tension and tighten the outer mounting location with a 13mm socket.

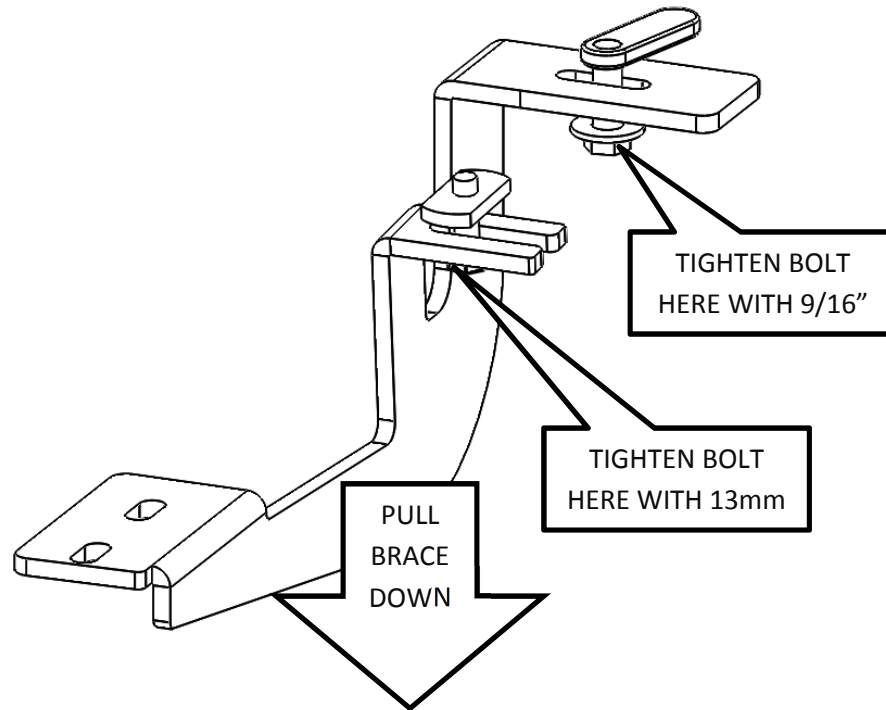

- 15** Attach the running board (A) to the driver brackets (B&D) using M8 nuts (G) and the square head bolts installed in step one. Move the running board to the desired location on the vehicle and then tighten the hardware with a 13mm socket.

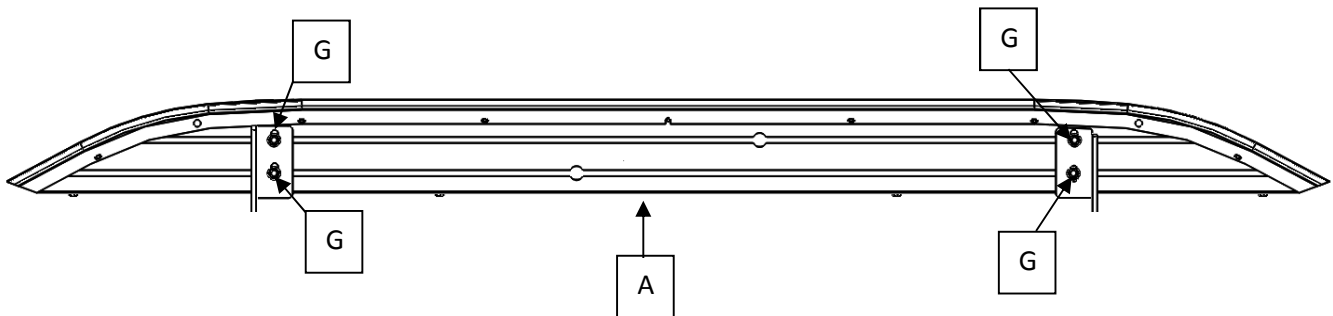

- 16** Repeat steps 4-15 on the passenger's side using the passenger brackets (C&E).