

newair[®]

AC-14100E
AC-14100H

Portable Air Conditioner



OWNER'S MANUAL

Read and save these instructions.



Manual v1.2

A Name You Can Trust

Trust should be earned and we will earn yours. Customer happiness is the focus of our business.

From the factory to the warehouse, from the sales floor to your home, the whole NewAir family promises to provide you with innovative products, exceptional service, and support when you need it the most.

Count on NewAir.

As a proud NewAir owner, welcome to our family. There are no robots here, real people shipped your product and real people are here to help you.

Contact Us:

For questions regarding your product, please contact us at:

Call: 1-855-963-9247
Email: support@newair.com
Online: www.newair.com

Connect with Us:



[Facebook.com/newairusa](https://www.facebook.com/newairusa)



[Instagram.com/newairusa](https://www.instagram.com/newairusa)



[YouTube.com/newairusa](https://www.youtube.com/newairusa)



[Twitter.com/newairusa](https://www.twitter.com/newairusa)

READ AND SAVE THESE INSTRUCTIONS.

TABLE OF CONTENTS

Safety Information & Warnings	5
Safe Operation Guidelines	5
Energy SAving Tips	7
Disposal Guidelines	7
Parts List.....	8
Parts Diagram.....	9
Assembly & Installation	10
Installation	10
Installing the Activated Carbon Filter	13
Operating Instructions	14
Control Panel Diagram.....	15
Control Operation.....	16
Energy Efficiency Boosting Function.....	18
Automatic Functions.....	19
Draining the Unit.....	20
Continuous Drainage	21
Heating Mode	21
Cleaning & Maintenance.....	22
Cleaning Your Portable Air Conditioner	22
End of Season Storage	23
Troubleshooting.....	23
Limited Manufacturer's Warranty	25

SPECIFICATIONS

MODEL NO.	AC-14100E	AC-14100H
VOLTAGE:	115V	
FREQUENCY:	60Hz	
POWER CONSUMPTION, COOLING:	1417W / 12.8A	
POWER CONSUMPTION, HEATING:	N/A	1270W / 11.4A
AIR VOLUME (MAX SPEED):	250 CFM	
DEHUMIDIFICATION CAPACITY:	2.96 pints/hour	

REFRIGERANT TYPE:	R-410A
NUMBER OF FAN SPEEDS:	3
TIMER:	1 – 24hours
EXHAUST PIPE DIMENSIONS:	5.59" x 59.06" (120 x 1500 mm)
COOLING CAPACITY:	8,500 BTUs
CEER:	7.66
NOISE RATING:	57 dB

SAFETY INFORMATION & WARNINGS

SAFE OPERATION GUIDELINES

To reduce the risk of fire, electrical shock and/or injury to persons or property please follow basic safety precautions. Be sure to read all instructions before using this appliance and observe the following safety tips:



ALWAYS DO THIS:

- ✓ Your air conditioner should be used in such a way that it is protected from moisture: e.g. condensation, splashed water, etc. Do not place or store your air conditioner where it can fall or be pulled into water or any other liquid. If your unit becomes wet, unplug immediately.
- ✓ Always transport your air conditioner in a vertical position and stand on a stable, level surface during use.
- ✓ Turn the product off when not in use.
- ✓ Contact a qualified person to carry out repairs. If the power cord is damaged it must be repaired by a qualified technician.
- ✓ Keep an air path of at least 14" (36 cm) all around the unit from walls, furniture and curtains.
- ✓ If the air conditioner is knocked over during use, turn off the unit and unplug it from the power supply immediately.



NEVER DO THIS:

- Do not operate your air conditioner in a wet room such as a bathroom or laundry room.
- Do not touch the unit with wet or damp hands or when barefoot.
- Do not press the buttons on the control panel with anything other than your fingers.
- Do not remove any fixed covers.
- Never use this appliance if it is not working properly, or if it has been dropped or damaged.
- Never use the plug to start and stop the unit. Always use the switch on the control panel.
- Do not place objects on the unit, and do not cover or obstruct the inlet or outlet grilles.
- Do not use hazardous chemicals to clean or come into contact with the unit. Do not use the unit in the presence of flammable substances or vapor such as alcohol, insecticides, gasoline, etc.
- Do not allow children to operate the unit unsupervised.

- Do not use this product for functions other than those described in this instruction manual.



Shock Hazard – Electrical Grounding Required

- Never attempt to repair or perform maintenance on the unit until the electricity has been disconnected.
- Never remove the round grounding prong from the plug and never use a two-prong grounding adaptor.
- Altering or cutting of power cord, removal of power cord, removal of power plug, or direct wiring can cause serious injury, fire, loss of property and/or life, and will void the warranty.
- Never use an extension cord to connect power to the unit.
- Avoid operating this beverage cooler in excessively moist or humid environments.



Important Precautions:

- Do not lift unit by door handle.
- Never install or operate the unit behind closed doors.
- Failure to clean the condenser every six months can cause the unit to malfunction.
- Allow unit temperature to stabilize for 24 hours before use.
- Do not block any internal fans.
- Keep the beverage cooler away from hazardous materials or combustible/flammable substances.
- Use only genuine supplier's replacement parts. Imitation parts can damage the unit, affect its operation or performance, and may void the warranty.

ENERGY SAVING TIPS

For maximum efficiency:

- Use the air conditioner in the recommended room size (Up To 525 Square Feet).
- Keep doors and windows closed while the portable air conditioner is in use.
- Keep curtains and blinds closed during the sunniest part of the day while the air conditioner is in operation.
- Keep the filters clean.
- Once the room or area has reached your desired comfort level, be sure to reduce the unit's temperature and ventilation settings.

DISPOSAL GUIDELINES

Do not dispose of this product as unsorted municipal waste. Collection of such waste separately for special treatment is necessary. Disposing of waste in forests and landscapes endangers your health when hazardous substances leak into the ground-water and find their way into the food chain.

It is prohibited to dispose of this appliance in domestic household waste. For disposal, the following options may be available:

- The municipality has established collection systems, where electronic waste can be disposed of free of charge to the user.
- When buying a new product, the retailer will take back the old product free of charge.
- The manufacturer will take back the old appliance for disposal free of charge to the user.
- As old products contain valuable resources, they can be sold to scrap metal dealers.

PARTS LIST

When you receive your unit, carefully remove the exterior and interior packaging. It is recommended that you retain the packaging for future use.

Check to make sure the following parts are included:

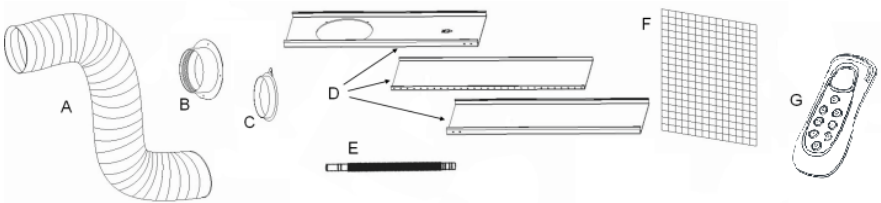

- **Air conditioner**
- **Exhaust hose (A)**
- **Hose adaptor (B)**
- **Adaptor cover (C)**
- **Extendable window kit (3 pcs) (D)**
- **Drain hose (E)**
- **Activated carbon filter (F)**
- **Remote control (G)**
- **1 instruction manual**

PARTS DIAGRAM

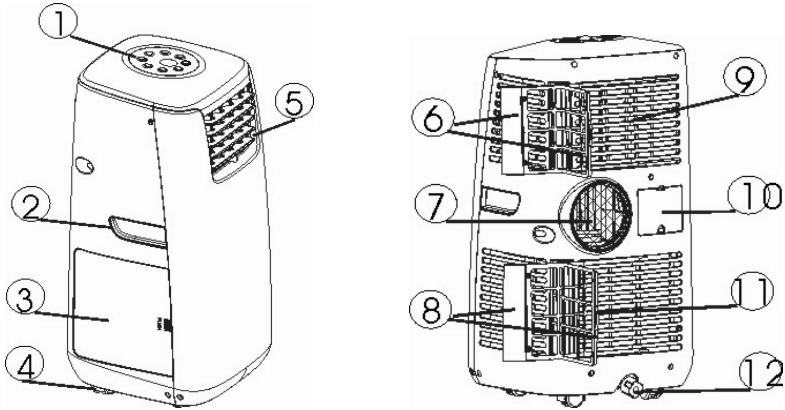

1. Control panel
2. Carrying handle
3. Water tank
4. Casters

5. Air louvers
6. Air filter
7. Exhaust air outlet
8. Air filter

9. Air inlet
10. Cord storage
11. Air inlet
12. Water plug/drainage hole

ASSEMBLY & INSTALLATION

INSTALLATION



Before connecting the appliance to a power source, let it stand upright for approximately 2 hours. This will reduce the possibility of a malfunction in the cooling system from handling during transportation.

LOCATION

This unit is a portable air conditioner that may be moved from room to room. Hot air must be exhausted out of the room for the appliance to work. This can be done with the included window kit or by cutting a hole into a wall.

- The air conditioner should be placed on a firm foundation to minimize noise and vibration.
- The unit has casters to aid placement, but it should only be rolled on smooth, flat surfaces. Use caution when rolling on carpet surfaces. Do not attempt to roll the unit over objects.
- The unit must be placed within reach of a properly rated grounded socket.
- Never place any obstacles around the air inlet or outlet of the unit.
- Allow 12 inches to 40 inches of space from the wall to the window for efficient air conditioning.

WINDOW SLIDER KIT INSTALLATION

Your window slider kit has been designed to fit most standard “vertical” and “horizontal” window applications. However, it may be necessary to improvise/modify some aspects of the installation procedures for certain types of windows.

Note: If the window opening is less than the minimum length of the window slider kit, cut the piece with a hole in it, so that it is the correct size to fit the window opening. Leave the hole in the window slider kit intact. Never cut out the hole in the window slider kit.

1. Open the window and insert the window kit into the open gap.
2. Close the window until the window kit is held securely. You may need to expand the size of the window kit using the included window spacers. This technique can also be used for sash windows.
3. Insert one end of the exhaust hose into the exhaust air outlet located on the back of the air conditioner. Attach the exhaust hose adapter to the other end of the exhaust hose and connect the adapter to the window kit.

Venting through a Wall

1. Cut a 6" (152 mm) diameter hole in the wall.
2. Insert one end of the exhaust hose into the exhaust air outlet located on the back of the air conditioner.
3. Insert the exhaust hose through the hole. On the other side of the wall, attach the round connector to the exhaust hose.
4. When the air conditioner is not in use, cover the hole with the provided exhaust cap.

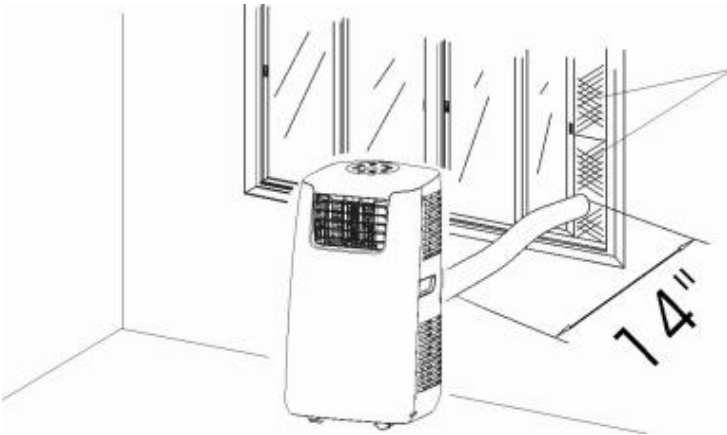

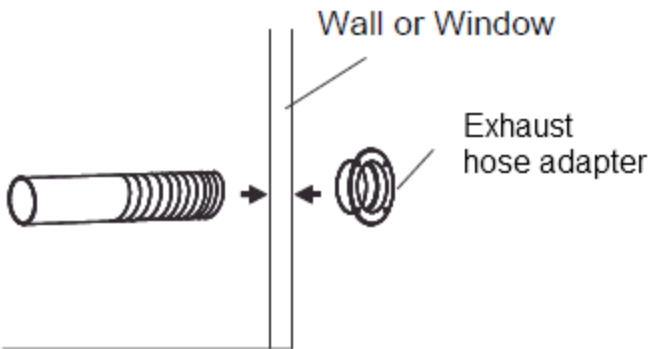

POSITIONING THE EXHAUST HOSE

- Slide the hose adaptor over the opening on the back of the unit.
- Insert one end of the exhaust hose into the adapter.
- Avoid kinks and bends in the exhaust hose. This can cause moist air to accumulate, resulting in overheating and unexpected shut offs.
- The exhaust hose may be extended from 12" (300 mm) to 59" (1500 mm), but for maximum efficiency use the shortest hose length possible.

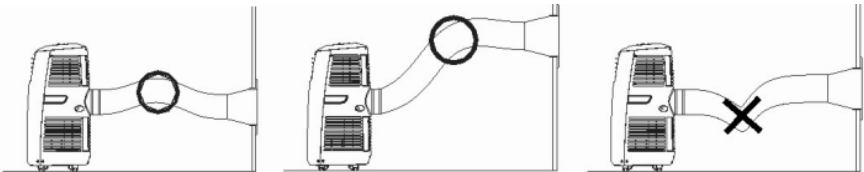

WARNING: The included exhaust hose is specially designed to fit the specifications of this unit. Do not extend it with your own hose, as this can cause the air conditioner to malfunction.

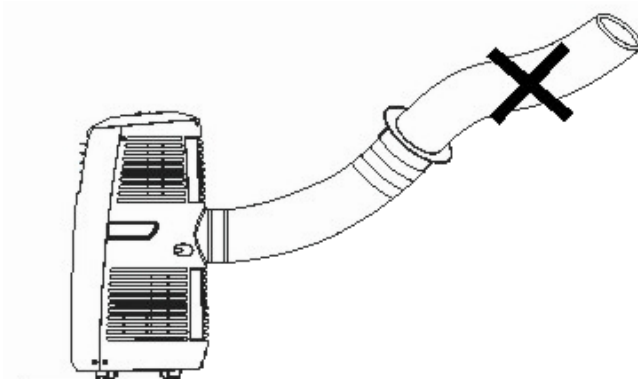

INSTALLING THE ACTIVATED CARBON FILTER

1. Remove the filter from the unit.
2. Separate the filter from the filter holder.

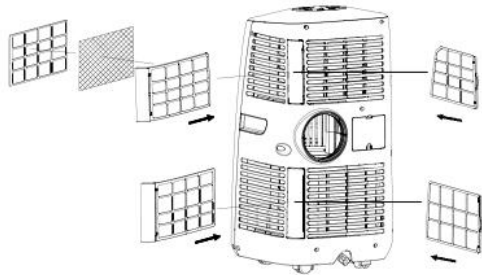

3. Remove the activated carbon filter from its plastic bag.
4. Insert the activated carbon filter into the filter and attach holder.
5. Reattach the filter holder onto the filter (make sure the active carbon filters will be held properly between the two pieces).

Insert the filter set into the unit.

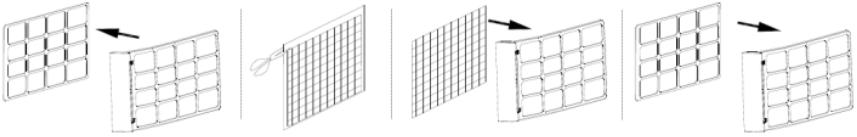

OPERATING INSTRUCTIONS

Before you begin, thoroughly familiarize yourself with the control panel and remote control and all its functions, and then follow the symbols for the functions you desire.

This unit can be controlled by the unit control panel alone or with the remote control.

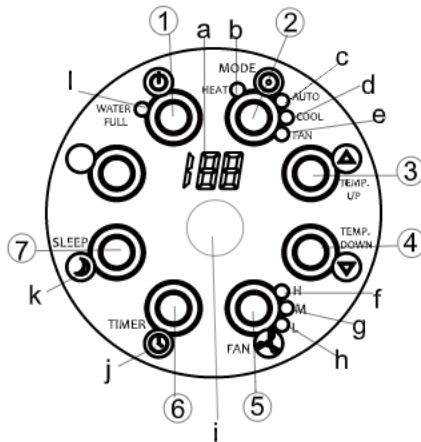
CONTROL PANEL DIAGRAM
**BUTTONS**

1. **ON/OFF (power) button**
2. **Mode button**
3. **Temperature increase button**
4. **Temperature decrease button**
5. **Fan speed (ventilation) button**
6. **Timer button**
7. **Sleep mode button**

LIGHTS AND INDICATORS

- a. **Display**
- b. **Heater indicator (AC-14100H only)**
- c. **Automatic mode indicator**
- d. **Cooling indicator**
- e. **Fan indicator**
- f. **High speed indicator**
- g. **Medium speed indicator**
- h. **Low speed indicator**
- i. **Receiver for remote control**
- j. **Timer indicator**
- k. **Sleep mode indicator**
- l. **Full tank indicator**

CONTROL OPERATION

TURNING THE UNIT ON AND OFF

1. Press the ON/OFF button. The unit will work in cooling mode on low fan speed. The preset temperature is 75°F.
2. At this time, the indicator lights will show any functions that are in progress. Please note the display window will show ambient room temperatures ranging from 32°F to 122°F.
3. To turn the unit off, press the ON/OFF button again.

SETTING THE FAN/VENTILATION SPEED

Press the fan speed button to select the desired fan speed (high, medium, or low). The desired fan speed will be shown in the display screen.

SETTING THE TIMER

1. Press the time button to set the desired number of operating hours (from 1 to 24 hours). When the set time has been reached, the machine will automatically turn off. The display window will show the number of hours being set as you press the TIMER button. If the TIMER is not set, the unit will work continuously.
2. By pressing the timer button without selecting any other modes or settings, you can set the number of hours to be delayed before the unit turns on. For example, if you press the timer to "2", the unit will automatically turn on after 2 hours.

HEATING MODE (AC-14100H model only)

This portable air conditioner can work as a heater because it has a heat pump. Ambient warm air is recycled and used to heat your immediate area. The exhaust hose will still need to be fitted onto the unit in order for the cold air to be removed. When in heating mode, the machine can be set on HIGH or LOW speed.

DEHUMIDIFICATION FUNCTION:

When the air conditioner is in dehumidification mode, the temperature cannot be adjusted, and the fan speed will automatically be set to low.

SETTING THE MODE/FUNCTION

1. Press the MODE button to select the desired mode (cooling, heating and fan). Heating mode is only available on the AC-14100H.
2. The selected mode's indicator light will turn on.

SETTING THE TEMPERATURE

1. Press the increase temperature or decrease temperature button to change the set temperature.
2. The display window will then indicate the set temperature. If no temperature is set, the display will show the room's ambient temperature.
3. Please note that the default temperature of this portable air conditioner is 75°F for cooling and 68°F for heating.

SLEEP MODE

1. When in cooling mode, press the sleep button. The set temperature will increase 1°F on the first hour, another 1°F on the second hour, and then maintain that temperature onwards.
2. When in heating mode, press the sleep button. The set temperature will decrease 1°F on the first hour, another 1°F on the second hour, and then maintain that temperature onwards.
3. In sleep mode, the fan will automatically be set to low. By pressing the sleep button again, the set temperature and fan speed will revert back to the previous settings.
4. The unit will shut down automatically after it has been in sleep mode for 12 hours.
5. Sleep mode will not work when the unit is in the fan, dehumidification, or auto mode. It will only work in cooling or heating mode.

ERROR MESSAGES:

This machine is equipped with a self-diagnosis function. If there is an error with the air conditioner, the LCD screen will display "E1" or "E2." If either of these error messages appears, please contact the manufacturer or a service center.



All the above functions can be controlled with the included remote. The remote requires 2 AAA batteries.

ENERGY EFFICIENCY BOOSTING FUNCTION

This unit is equipped with an energy efficiency boosting function. By adding water to the tank as shown below, energy efficiency can be increased, therefore saving you money on your energy bill and conserving the environment. The water helps to cool the compressor, cooling the exhaust and minimizing frost accumulation.

This is very effective for dry, arid climates because an air conditioner needs some humidity to work efficiently and cooling the compressor will provide cooler air. However, it is not recommended for especially humid areas because the unit will have plenty of moisture in the air with which to run efficiently.

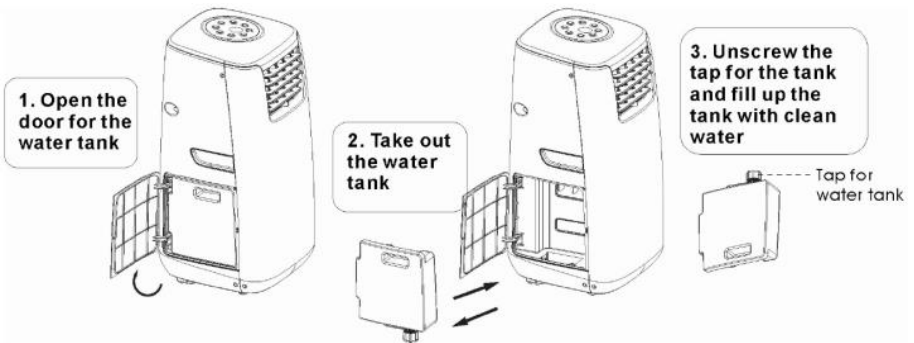

Please note: To use the energy efficiency boosting function, please follow the steps above at least one hour before operation.



CAUTION: After turning off the unit, please wait at least 3 minutes before turning it back on. This will prolong the life of the compressor.

AUTOMATIC FUNCTIONS

- The cooling system will turn off if the ambient temperature is lower than the set temperature. However, the fan will continue operating at the set level. Once the ambient temperature rises above the set temperature, cooling will resume.
- The heating system will turn off if the ambient temperature is higher than the set temperature. However, the fan will continue operating at the set level. Once the ambient temperature drops below the set temperature, heating will resume.
- This machine is equipped with an ANTI-FROST function. When using the heating function in low temperature the heater will occasionally stop heating in order to melt any frost that has accumulated within the air conditioner. Normal operation will resume in a few moments.

DRAINING THE UNIT

During the cooling and dehumidifying processes, some water will be extracted from the air and stored within the unit's water reservoir.

If the water reservoir is full, both the compressor and motor will stop and the unit will beep (press any button to stop the beeping sound). The full water tank indicator light will also start flashing.

To resume cooling, first empty the reservoir by following these steps:

1. Turn off the air conditioner and unplug it from the wall socket. To prevent water leakage, avoid moving the unit when full.
2. Place a container (such as a small pan) underneath the drainage port.
3. Remove the water plug from the drainage port and allow the water to drain out.
4. When the container is almost full, replace the water plug back into the drainage port and empty the water container.
5. Repeat until the water reservoir is completely empty.
6. Replace the water plug back into the drainage port and make sure it is firmly in place.
7. Turn the unit back on. The warning signal should be off.

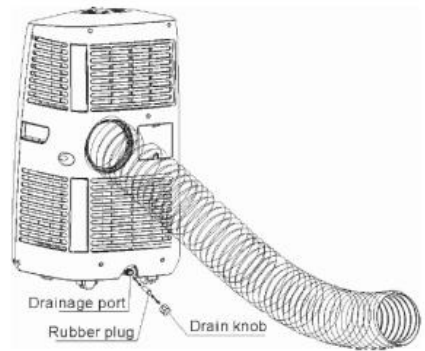

CONTINUOUS DRAINAGE

To operate the unit continuously without manually emptying the tank, follow these steps:

1. Remove the drain plug from the back of the unit and retain it for future use.
2. Connect the drainage hose included with the unit to the drainage port as shown.
3. Connect the other end of the hose into a drain.

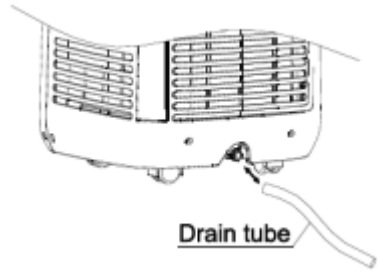

Please note:

- The drain must be at or below the level of the drainage port.
- The full water tank indicator will not work when the unit is being continuously drained.
- To extend the drainage hose, you can add an extension hose with an overall diameter of approximately 0.7" (18 mm).

HEATING MODE

MODEL AC-14000H ONLY.

- In order to properly exhaust cool air, make sure the exhaust hose and window kit are installed correctly.
- Set up the air conditioner for continuous drainage using the included drain tube.
- The working range for the heating function is 45°F to 77°F. The unit may not provide optimal heating if used in temperatures outside this range.

CLEANING & MAINTENANCE

CLEANING YOUR PORTABLE AIR CONDITIONER

Always unplug the air conditioner from the power supply before cleaning. To maximize the efficiency of the air conditioner, regularly clean the unit.

CLEANING THE HOUSING

- Use a soft, damp cloth to wipe the body clean.
- Never use strong chemicals, gasoline, detergents, chemically-treated cloths, or any other cleaning solutions to clean the air conditioner, as these can all potentially damage the unit's housing.

CLEANING THE FILTERS

- Clean the air filter at least once every two weeks to prevent interior fan malfunction due to dust.
- Use a vacuum cleaner or tap the filter lightly to remove loose dust and dirt from the filters and then rinse them thoroughly under running water (no warmer than 104°F).
- Thoroughly dry the filters before replacing them back into the unit.

PLEASE NOTE: NEVER OPERATE THE UNIT WITHOUT FILTERS.

END OF SEASON STORAGE

1. Completely drain any condensed water from the unit.
2. Set the air conditioner on fan mode for a few hours to thoroughly dry the inside of the unit.
3. Clean or change the filter.
4. Unplug and store the power cord behind panel as shown.
5. Place the unit back in its original carton and store it in a clean, dry area.

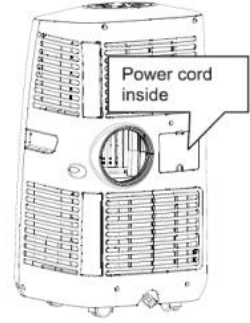

TROUBLESHOOTING

Problem	Possible Causes	Solution
The air conditioner does not function.	The unit may be plugged in using a different voltage.	Check if using the wrong voltage.
	The circuit breaker may be tripped or there is a blown fuse.	Reset the circuit breaker or check for a blown fuse.
	The water tank is full.	If the full water tank indicator light is flashing, empty the water reservoir.
	The ambient room temperature is lower than the set temperature.	Lower the set temperature.
The unit does not produce adequate cooling.	The unit is in direct sunlight.	Close any curtains or move the unit to a more shaded area.
	Too many windows or doors are open.	Close doors and windows.

Problem	Possible Causes	Solution
	There is an additional heat source in the room or there are too many people in the room.	Lower the set temperature.
	The filter is dusty or dirty.	Clean the filter per instructions above.
	Air inlet or air outlet is blocked.	Make sure there are no obstructions to proper air circulation through the unit.
	The ambient room temperature is lower than the set temperature.	Lower the set temperature.
The unit is noisy.	The unit is not leveled.	Ensure the unit is positioned on a flat, level surface.
The compressor does not work.	The compressor has overheated and shut off.	Wait for temperature to drop and then turn the unit on again.

**NEVER TRY TO REPAIR OR DISMANTLE THE UNIT YOURSELF.
UNAUTHORIZED REPAIRS CAN VOID THE WARRANTY AND ENDANGER THE
UNIT.**

LIMITED MANUFACTURER'S WARRANTY

This appliance is covered by a limited manufacturer's warranty. For one year from the original date of purchase, the manufacturer will repair or replace any parts of this appliance that prove to be defective in materials and workmanship, provided the appliance has been used under normal operating conditions as intended by the manufacturer.

Warranty Terms:

During the first year, any components of this appliance found to be defective due to materials or workmanship will be repaired or replaced, at the manufacturer's discretion, at no charge to the original purchaser. The purchaser will be responsible for any removal or transportation costs.

Warranty Exclusions:

The warranty will not apply if damage is caused by any of the following:

- Power failure
- Damage in transit or when moving the appliance
- Improper power supply such as low voltage, defective household wiring or inadequate fuses
- Accident, alteration, misuse or abuse of the appliance such as using non-approved accessories, inadequate air circulation in the room or abnormal operating conditions (extreme temperatures)
- Use in commercial or industrial applications
- Fire, water damage, theft, war, riot, hostility or acts of God such as hurricanes, floods, etc.
- Use of force or damage caused by external influences
- Partially or completely dismantled appliances
- Excess wear and tear by the user

Obtaining Service:

When making a warranty claim, please have the original bill of purchase with the purchase date available. Once confirmed that your appliance is eligible for warranty service, all repairs will be performed by a NewAir™ authorized repair facility. The purchaser will be responsible for any removal or transportation costs. Replacement parts and/or units will be new, re-manufactured or refurbished and is subject to the manufacturer's discretion. For technical support and warranty service, please email support@newairusa.com.