

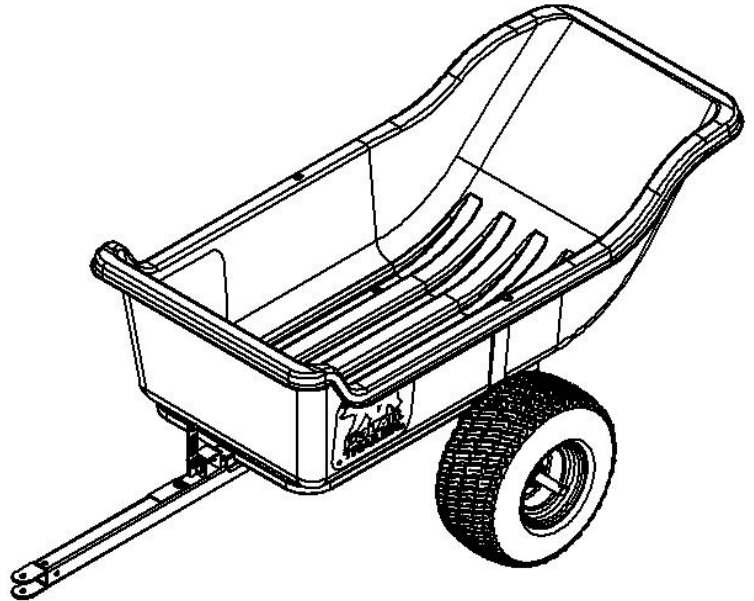

HD 1200



- SPECIFICATIONS

Model Number:	8232
Part Number:	108383
Load Capacity:	1200 lbs. Load
Load Size:	15 Cubic Feet
Overall Dimensions:	84" x 45" x 31"
Overall Weight:	107 lbs.
Body Dimensions:	62" x 31" x 18"
Tire Size:	18 x 8.5-8
Instruction P/N	102653-B

NOTICE: Once used, this trailer cannot be returned to the store. If you have a warranty claim, please read and follow Warranty Information directions below.

WARRANTY INFORMATION

CLAM OUTDOORS INC. warrants to the original retail purchaser its product be free from manufacturers defects for (3) years from the date of the original purchase. Clam Outdoors Inc will replace or repair any part found defective within the (3) years time limit. All parts must be returned to Clam Outdoors Inc. Before returning any parts, you must first call or write and acquire a return authorization. All returns must be returned postage-prepaid and include the original cash register receipt (date and purchase price).

To submit a warranty claim request, please use one of the following methods:

- Customer Service Hrs: 9am to 4pm, Monday – Friday Central Standard Time
- Clam Corporation
Attn: Customer Service – Warranty Department
12135 Brockton Lane
Rogers, MN 55369
- Phone: 763-231-4120
- Fax: 763-231-4121
- Email: customerservice@clamcorp.com
- Website: Clamoutdoors.com

The warranty does not apply to any Polar Trailer which has been subjected to an accident, improper installation, modification, adjustment, repair, misuse, misapplication, neglect, including but not limited to improper maintenance, or use of unauthorized parts or attachments.

LIMITATION OF LIABILITY

It is expressly understood that Clam Outdoors Inc. liability for its products, whether due to breach of warranty, negligence, strict liability, or otherwise, is limited to the repair of the product as stated above. Clam Outdoor Inc. is not liable for any injury, loss, damage, or expense, whether direct or consequential, including but not limited to loss of use, income, profit, or damage to material arising in connection with the sale, installation, use of, inability to use, or the repair or replacement of Clam Outdoor Inc. products. Clam Outdoor Inc. reserves the right to make alterations or modifications in its products at any time, which in its opinion, may improve the performance and efficiency of the product. It shall not be obligated to make such alterations or modifications to products already in service.

WARNING:

- **THIS ATTACHMENT IS INTENDED FOR USE IN LAWN CARE AND HOME APPLICATIONS.**
- **DO NOT TOW BEHIND A VEHICLE ON A HIGHWAY OR IN ANY HIGH SPEED APPLICATION.**
- **THIS PRODUCT HAS BEEN DESIGNED FOR OFF-ROAD USE ONLY.**
- **MAXIMUM TOW SPEED IS 10 MPH.**

 THE FOLLOWING STATEMENTS ARE SUGGESTIONS AND DO NOT SUPERCEDE OR ELIMINATE ANY TOWING AND SAFETY INSTRUCTIONS LISTED IN ANY OWNERS MANUALS FOR ANY PRODUCT BEING USED FOR THE PURPOSE OF TOWING ANY CLAM OUTDOORS INC. PRODUCTS. ALWAYS REFER TO THE TOWING VEHICLES MANUAL, GUIDELINES OR INSTRUCTIONS.

Transporting Loads Safely

- Stopping distance increases with speed and weight of towed load. Travel slowly and allow extra time and distance to stop.
- Total towed weight must not exceed limits specified in towing vehicle operator's manual.
- Excessive towed load can cause loss of traction and loss of control on slopes. Reduce towed weight when operating on slopes.
- Never allow children or others in or on towed equipment.
- Use only approved hitches. Tow only with a machine that has a hitch designed for towing. Do not attach towed equipment except at the approved hitch point.
- Follow the manufacturer's recommendations for weight limits for towed equipment and towing on slopes.
- Do not turn sharply. Use additional caution when turning or operating under adverse surface conditions. Use care when reversing.
- Do not shift to neutral and coast downhill

Protect Bystanders

- Keep bystanders away when you operate a towed attachment.
- Before you back machine and attachment, look carefully behind attachment for bystanders.

Keep Riders off Towed Attachment

- Keep riders off of a towed attachment.
- Riders on a towed attachment are subject to injury, such as being struck by objects and being thrown off the attachment during sudden starts, stops and turns.
- Riders obstruct the operator's view, resulting in the attachment being used in an unsafe manner.
- Keep riders off of the hitch bracket or trailer tongue.

Disconnecting Towed Attachment

- Unload trailer.
- Stop attachment on level ground.
- Stop machine engine.
- Lock machine park brake.
- Block attachment wheels

Lock Pin Hole

- A hole has been provided in the Latch Plate to lock the Latch Mechanism if desired.

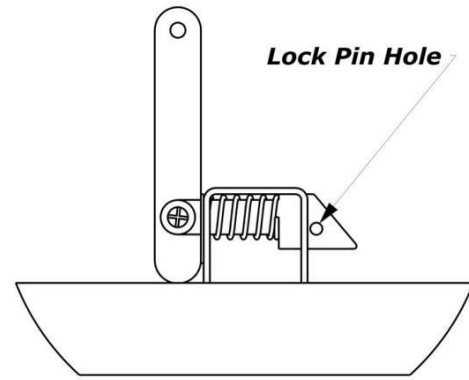

- Replacement Parts

ITEM NO.	PART NUMBER	DESCRIPTION	QTY.
1	102587	TIRE, 18X8.50-8 TURF	2
2	101721	PIVOT TUBE, 2" X 2"	1
3	101743	AXLE WELDMENT	1
4	101312	WASHER, 1/2" FLAT	6
5	101313	NUT, 1/2-13 NYLOCK	6
6	101739	BOLT, 1/2-13 X 3.50"	6
7	101740	NUT, 3/8-16 NYLOCK	6
8	101741	WASHER, 3/8" FLAT	6
9	101749	BOLT, 3/8-16 X 1.25"	6
10	101755	U-FRAME WELDMENT	1
11	101824	BLACK PULL SUPPORT PLATE	1
12	101732	WASHER, 1" FLAT	4
13	101823	1/4" LYNCH PIN	2
14	101822	HITCH PULL WELDMENT	1
15	102238	HITCH ASSEMBLY	1
16	101939	BASE, 1200 POLAR TRAILER	1
17	102654	DECAL, POLAR, HD1200	1
18	102658	DECAL, POLAR, ONE TOUGH TRAILER	1
19	103280	SQUARE WASHER	4
20	109265	#4 PHILLIPS SCREW DRIVER	1
21	102653	ASSEMBLY INSTRUCTIONS	1

DO NOT FULLY TIGHTEN THE NUTS AND BOLTS UNTIL THE TRAILER IS FULLY ASSEMBLED. THIS WILL AID GREATLY IN THE ASSEMBLY PROCESS.

STEP ONE

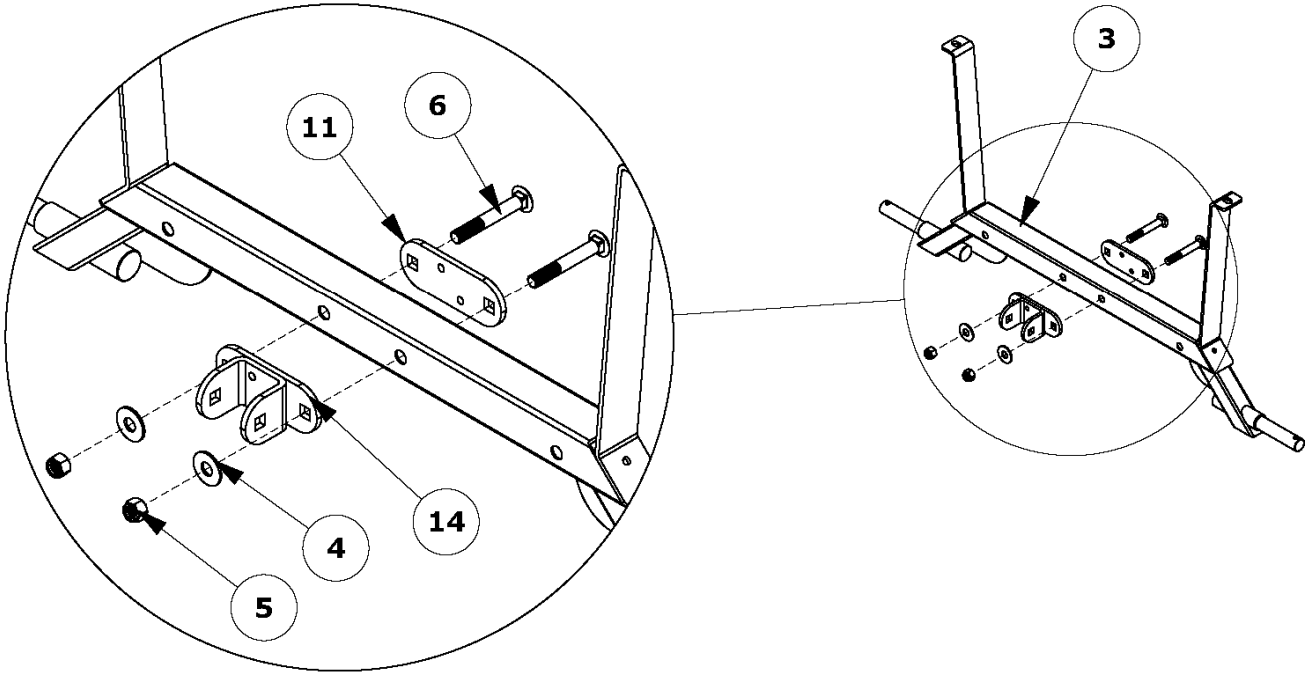

STEP TWO

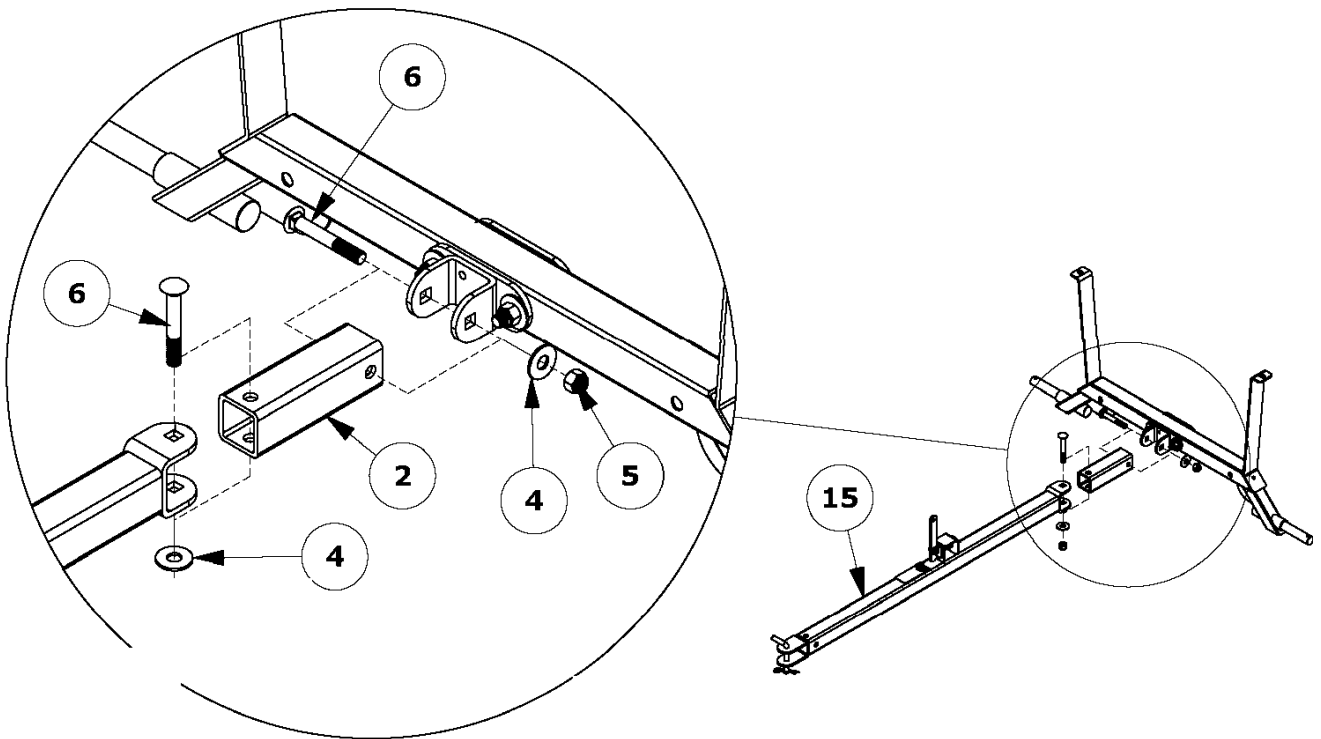

STEP THREE

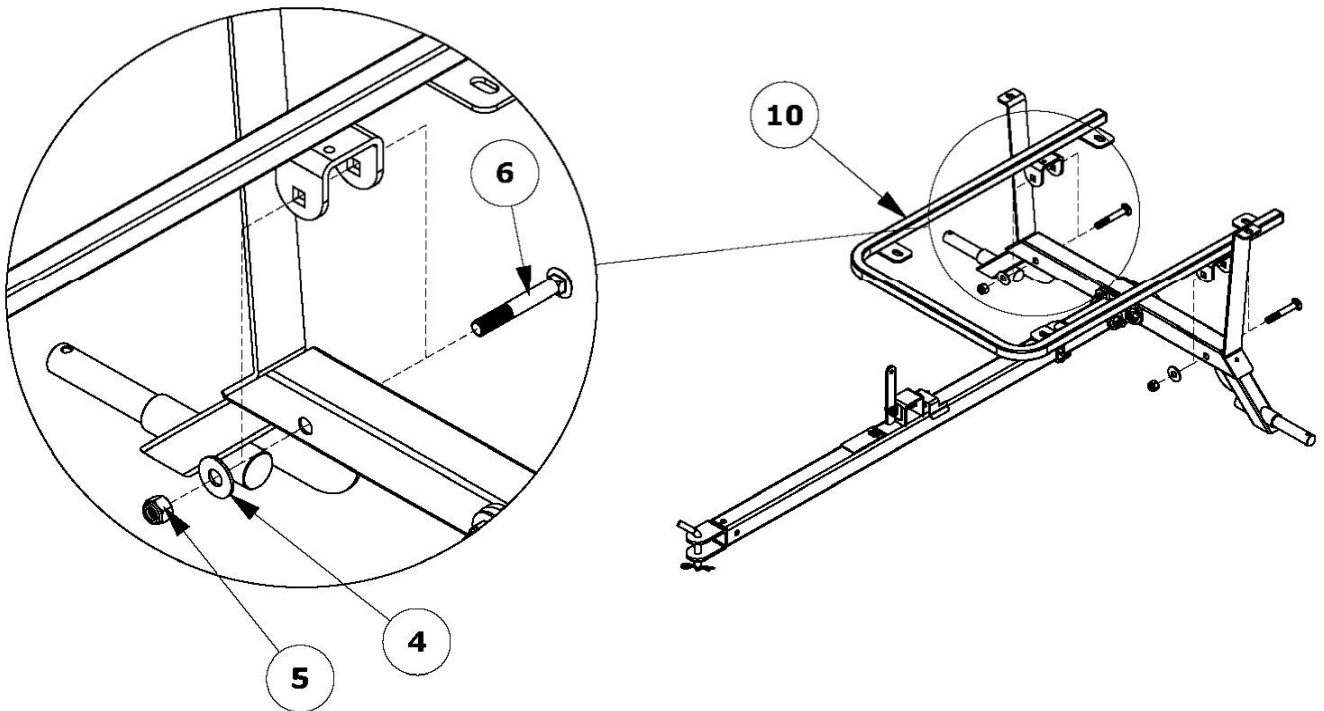

STEP FOUR

Insert pin after wheel is installed.

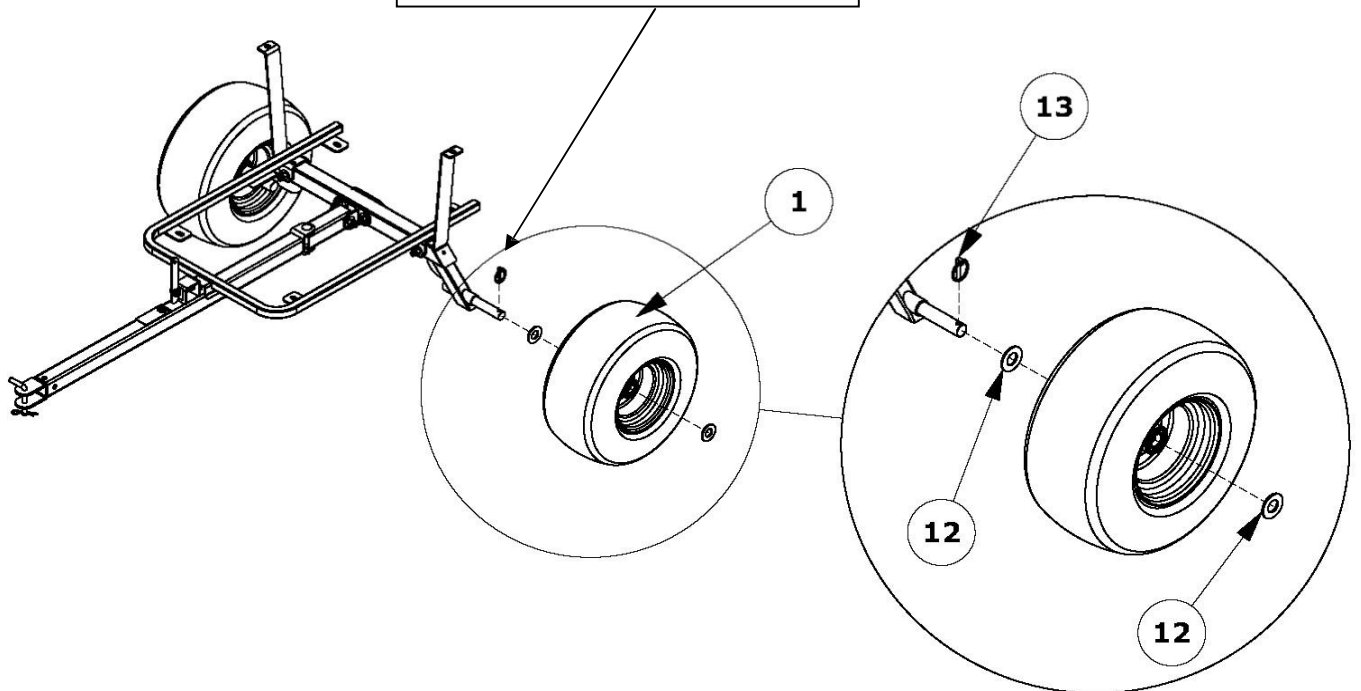

STEP FIVE

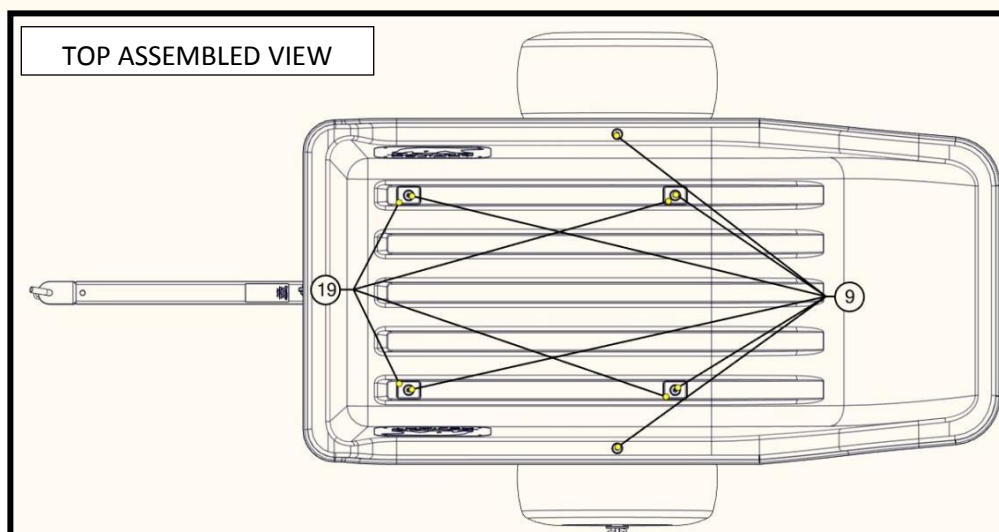
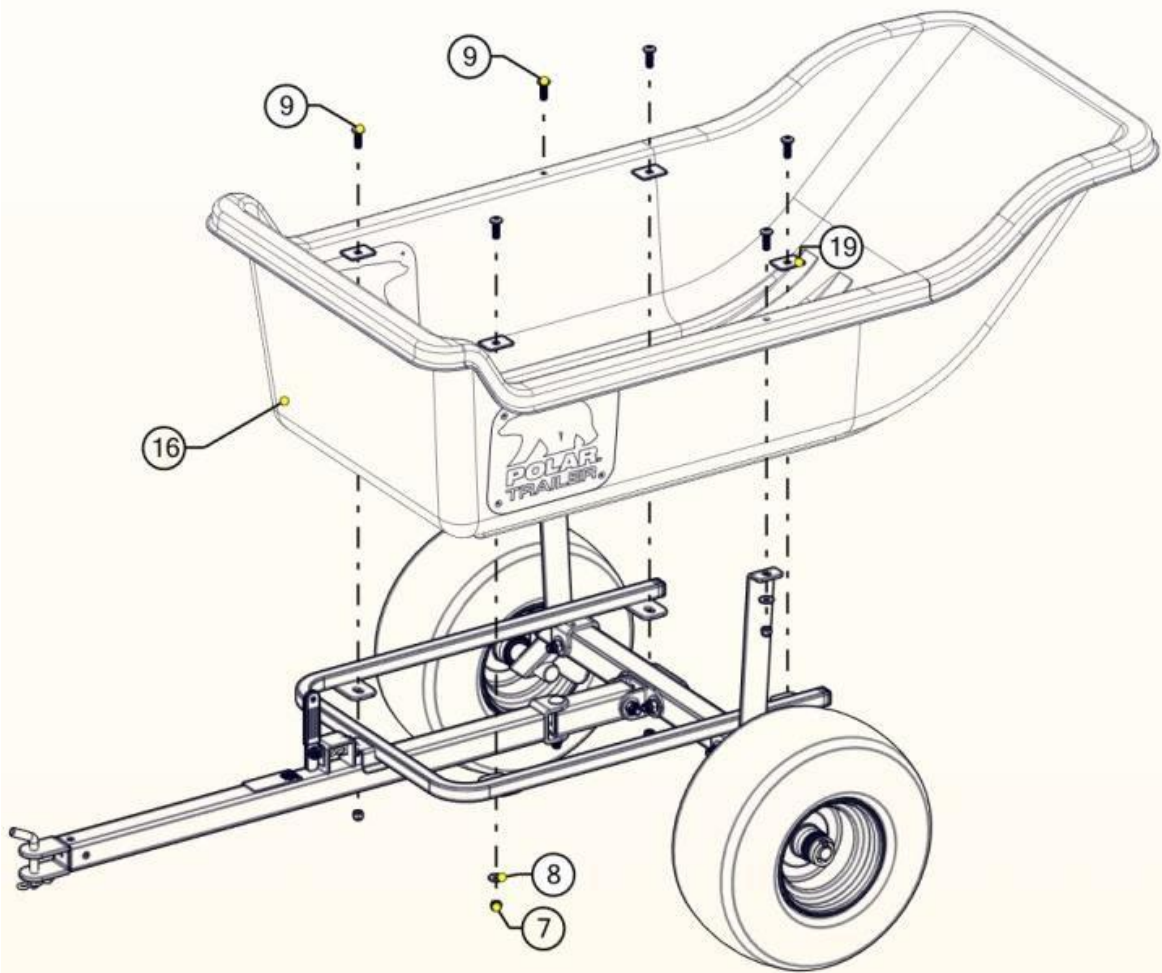

At this point tighten all of the nuts and bolts to finish the assembly process.