

Installation Instructions (Continued)

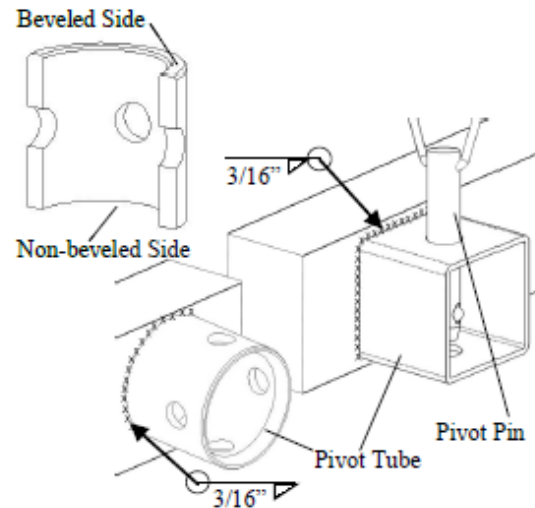

To attach a handle assembly:

- 1) Insert the long spacer into the roller followed by the thin spacer and the bolt.
- 2) Secure to the crank stem with the nut provided.

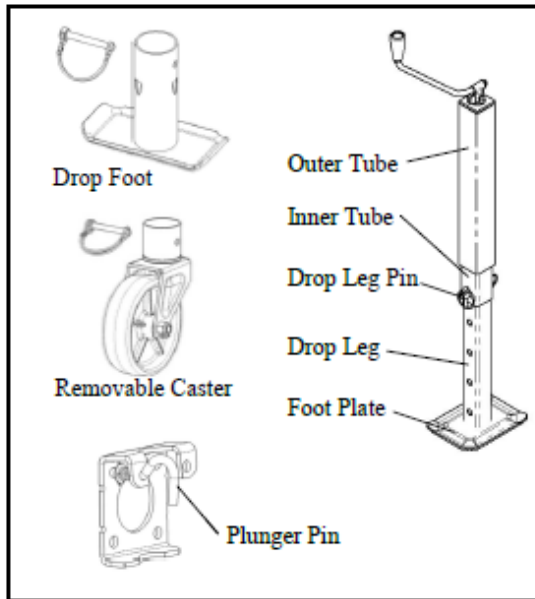
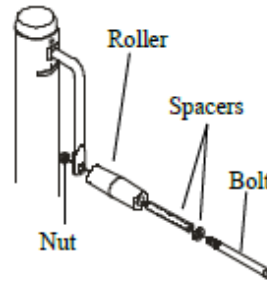

To attach a wheel assembly:

- 1) Insert the long spacer into the wheel.
- 2) Set the wheel into the caster body and place the bolt through the caster body and wheel.
- 3) Secure with the nut provided.

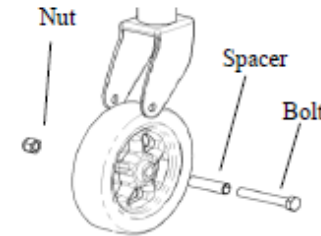

To attach a top-wind handle assembly:

- 1) Place the washer over the screw stem and then place the handle over the screw stem.
- 2) Secure the handle to the screw stem with the bolt and nut provided.

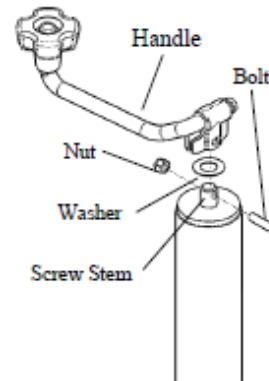

Heavy Duty Caster:

- 1) Jack capacity limited to lesser of jack or caster.
- 2) Use 4 3/8" bolts, washers, and locknuts as shown.

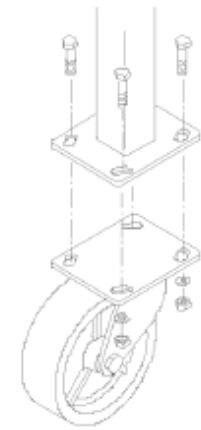

Weld-on Pivot Tube Mounting Instructions (Round and Square Pivot Tubes):

- 1) All welding must be performed by an AWS certified welder.
- 2) The non-beveled side of the pivot tube is welded to the tongue unless otherwise specified on hardware.
- 3) Place the weld-on pivot tube against the tongue and weld all around with a 3/16" fillet weld. Align one set of pivot mount holes vertically.
- 4) Mate the jack to the pivot tube and secure with the supplied pin.