

AUTO-LOCK GATE - Model MG15

FOR OPENINGS 26" (66cm) - 40" (102cm)

JAN2021

ASSEMBLY INSTRUCTIONS

GATE IS RECOMMENDED FOR CHILDREN BETWEEN 6 AND 24 MONTHS.
IF INSTALLING AT TOP OF STAIRS, INSTALL A MINIMUM OF THREE INCHES FROM END OF FIRST STEP.

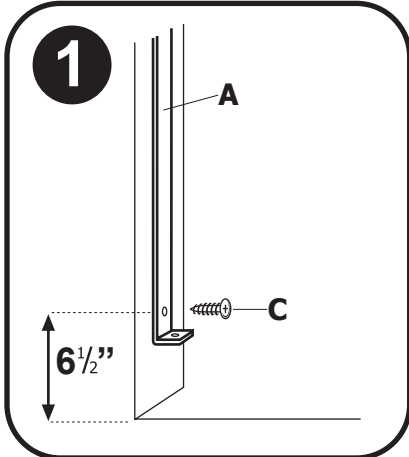
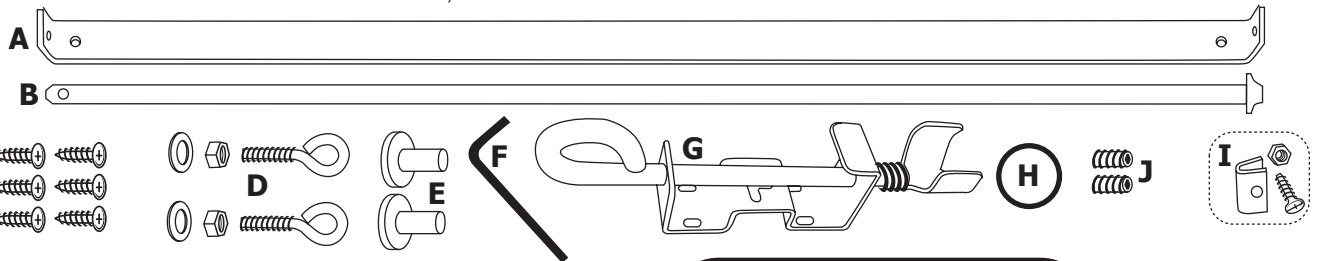

1. Install hinge bracket (A) to wall (stationary side of gate) using Phillips screw (C) beginning 6 1/2" above floor surface.

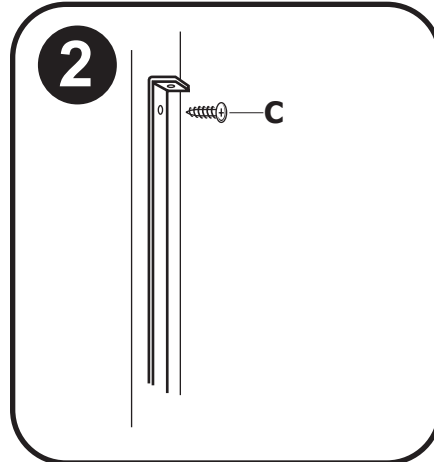

2. Install second screw (C) in top of hinge bracket securing it to the wall.

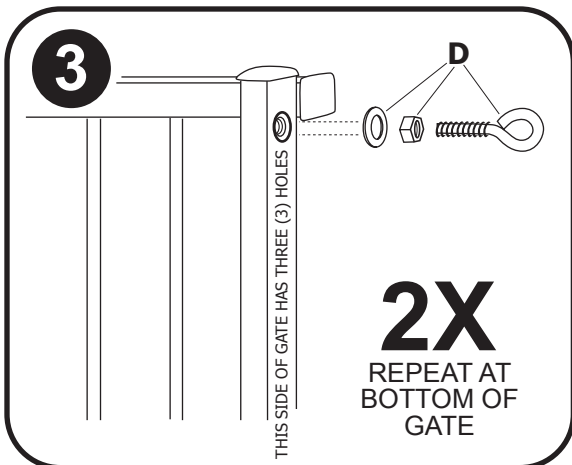

3. Insert eye bolts (D) into top and bottom of hinge side gate (side with three holes). Be sure nuts are tight.

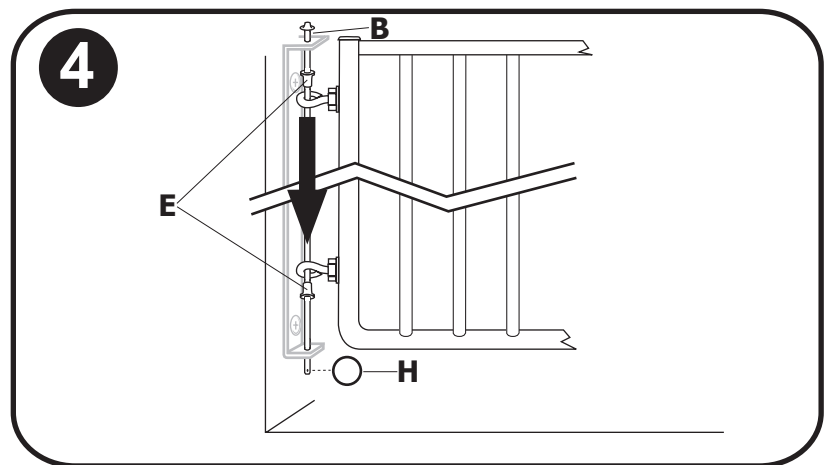

4. Hang gate by inserting hinge rod (B), through top of mounted hinge bracket (A), through upper plastic shoulder washer (E), through both eye bolts, through lower plastic shoulder washer (E), and finally through bottom of hinge bracket. To secure hinge rod, insert key ring (H) through hole in end of hinge rod.

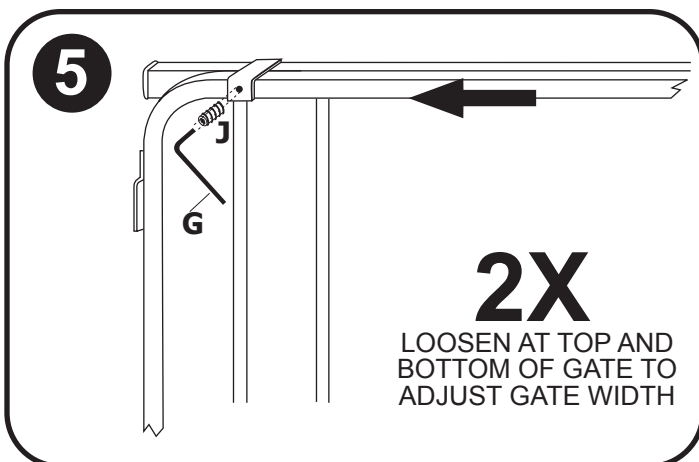

5. Set gate to width by holding latch assembly against mounting wall (see beginning of **STEP 6**). Use Allen wrench (F) to insert set screws (J) and tighten top and bottom of gate.

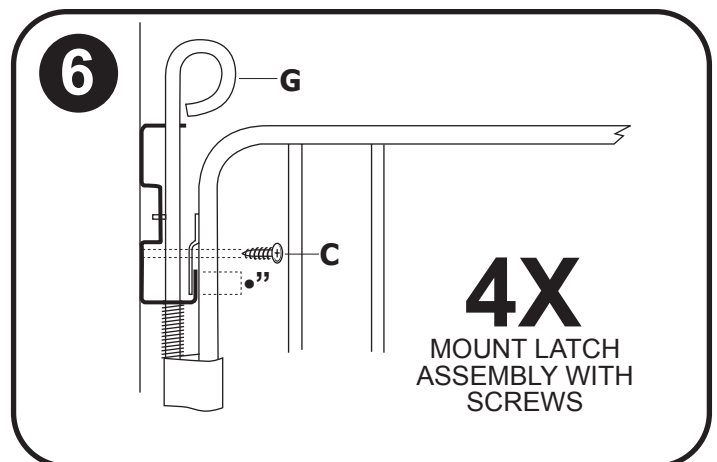

6. Hold latch assembly (G) against opposite wall and extend gate until at least 1/2" of safety bracket will interlock with flange of latch. Mark position of latch assembly screw holes with pencil. Swing gate out of way and mount latch assembly to wall. Check closure of gate and tighten set screws from STEP 5 to secure gate width.

ONE-WAY STOP BRACKET

Install one-way stop bracket (I) on one side of latch to have gate open in only one direction.

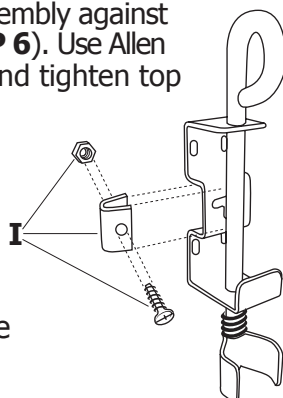

WARNING

Children have died or been seriously injured when gates are not securely installed.

- ALWAYS install and use gates as directed using all required parts.
- STOP using when a child can climb over or dislodge the gate.
- Use only with the latching mechanism securely engaged.
- NEVER use to keep child away from pool.

GATE OPERATION

FOR OPENING:

STEP ONE: Lift latch hook with finger.

STEP TWO: Twist latch in direction desired to open gate.

STEP THREE: Leave latch open.

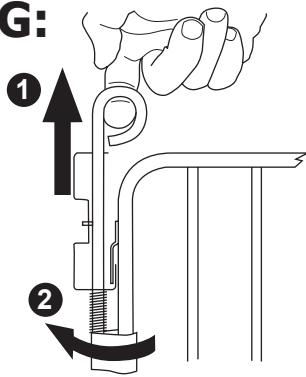

FOR CLOSING:

Simply push gate back into latch assembly from the direction opened until a "click" sound is heard.

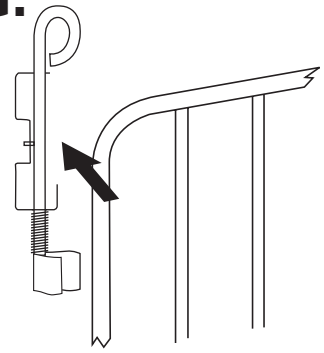

GATE MAINTENANCE

To clean, rinse with lukewarm water, wash gently with mild soap or detergent and lukewarm water, using a soft cloth or sponge. Rinse again. Dry with a soft cloth or sponge to prevent water spotting. **DO NOT SCRUB** or use brushes or squeegees.

Discontinue use of the gate if it becomes damaged, broken, or disassembled.

GATE CARE & REMINDERS

At **CARDINAL GATES, INC.**, we design what we believe to be the very best, and most user friendly gates available. Our gates are built to last many years with proper use and care. Here are a few suggestions...

- Close gates gently - do not slam - to prevent damage to latch mechanism.
- When closing, be sure safety bracket on gate frame engages as depicted in instructions.
- For safety, always close gate when not in use. Children should not be allowed to swing on an open gate as this can damage hinge mount.
- Keep allen wrench in a secure place. We suggest removing set screws when separating sections for cleaning. Periodically check all screws, bolts, etc. for security and proper adjustment.

CARDINAL GATES, INC., offers many accessories such as extensions, stair kits, and other safety products. Check with your dealer or call **CARDINAL GATES, INC.** at 1-800-318-3380.

We sincerely hope that you thoroughly enjoy many years of service from your **CARDINAL GATE**.

GATE WARRANTY

Your Cardinal Gate is warranted to be free of manufacturing defects for a period of one year from the date of purchase when used in homes, and according to manufacturers instructions. When used commercially, such as day care centers, the warranty is 90 days.

Cardinal Gates, Inc. will either repair or replace, at our option, any parts necessary to correct defects in material or workmanship during the warranty period. The warranty disclaims liability for incidental, special and consequential damages of any nature.

TO EXERCISE WARRANTY:

Ship your gate in a protective carton, freight prepaid to:
CARDINAL GATES, INC.
79 Amlajack Way
Newnan, GA 30265

You must include the following:

1. Proof of purchase (store receipt, etc.).
2. Brief note describing problem with gate.
3. Full return address along with phone number.

FOR FURTHER ASSISTANCE

Call 1-800-318-3380

CARDINAL GATES

If it's a Cardinal, It's the Best!

79 Amlajack Way
Newnan, GA 30265
770-252-4200

www.cardinalgates.com