

HARDWARE PACKAGE

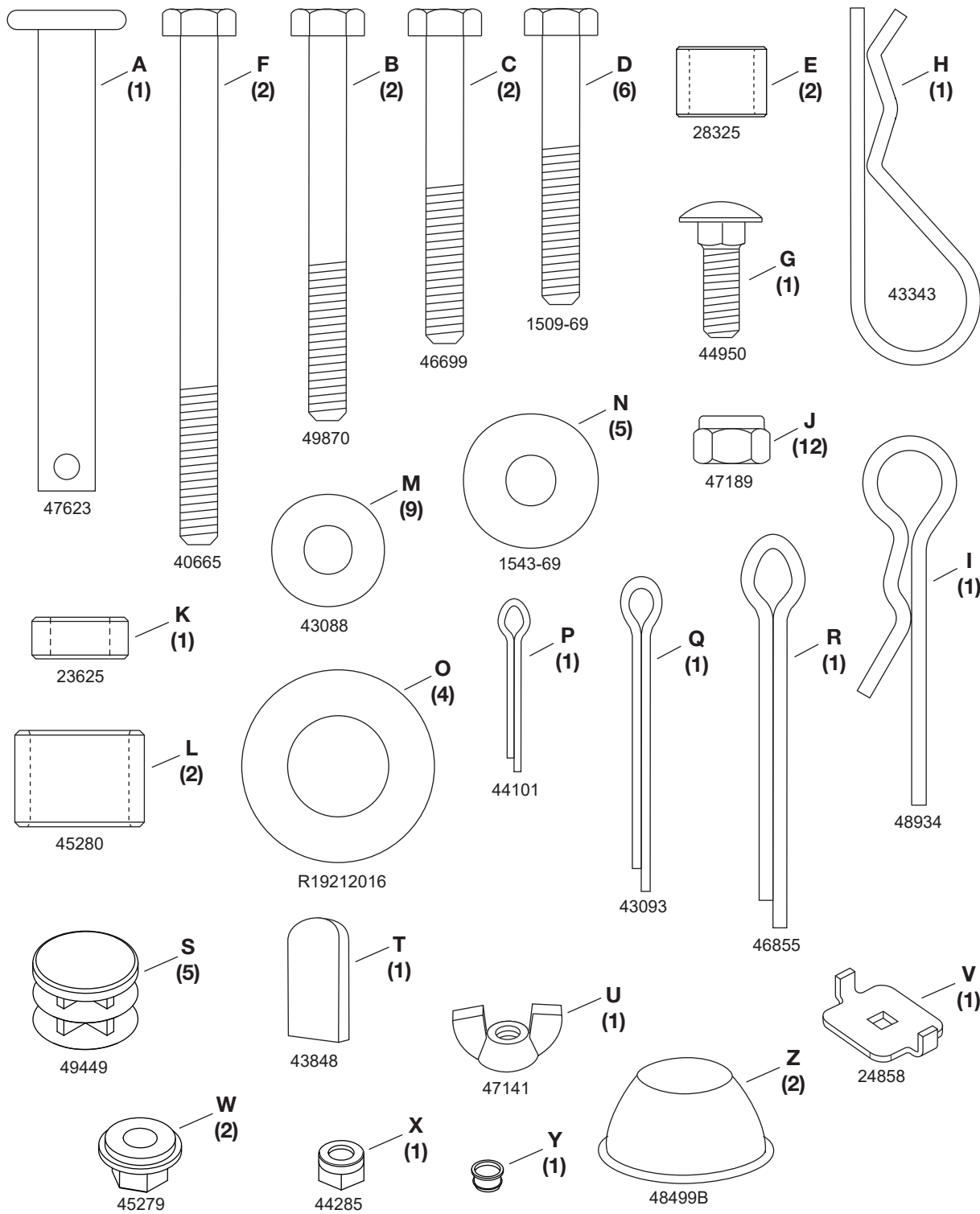

TOOLS REQUIRED FOR ASSEMBLY

- (1) Hammer
- (1) Pliers
- (2) 7/16" Wrenches
- (2) 1/2" Wrenches

IMPORTANT: To avoid assembly difficulties, **DO NOT TIGHTEN** bolts until STEP 13 unless otherwise instructed. If you have difficulty assembling parts, the bolts may need to be loosened.

STEP 1: (SEE FIGURE 1)

- Insert a plug (S) in to the end of the hitch tube (8).
- Install the hitch pin (A) in the hitch bracket and hitch tube and secure it with the hairpin cotter (H).

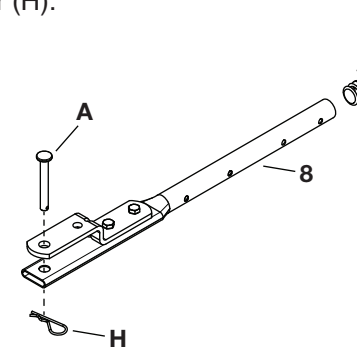

Figure 1

STEP 2: (SEE FIGURE 2)

- Attach the hitch support tubes (3), and (4) to the hitch tube using one 1/4" x 3-1/2" hex bolt (F) and 1/4" nylock nut (J). **Do not tighten completely.**

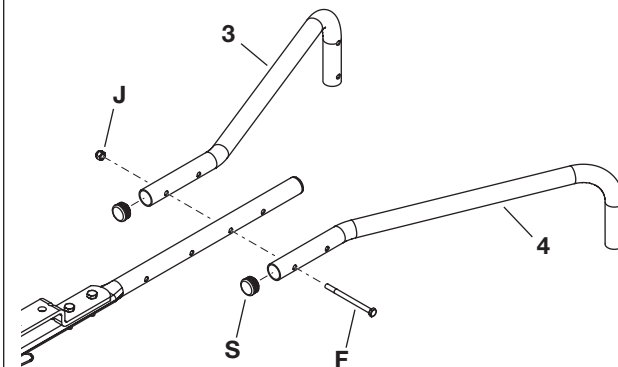

Figure 2

STEP 3: (SEE FIGURE 3)

- Insert the hex bushings (W) into the ends of the hopper support tubes (5).
- Assemble the axle/gearbox assembly and hopper support tubes (5) to the hitch support tubes as shown one 1/4" x 2" hex bolt (C), spacer (E), and 1/4" nylock nut (J). **Do not tighten completely.**
- Orient the axle/gearbox assembly so that the end of the axle with the hole is placed on the left side of the spreader.

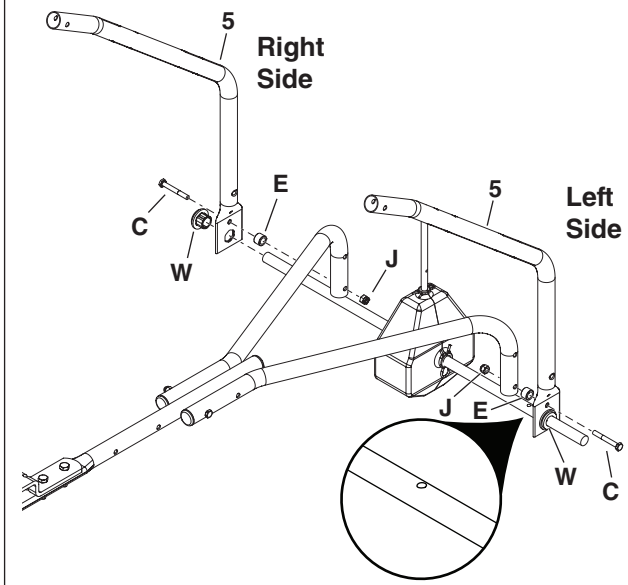

Figure 3

STEP 4: (SEE FIGURE 4)

- Insert the bushing (Y) into the cross brace (7).
- Attach the cross brace to the hopper support tubes using two 1/4" x 2-1/2" hex bolts (B) and 1/4" nylock nuts (J). **Do not tighten completely.**

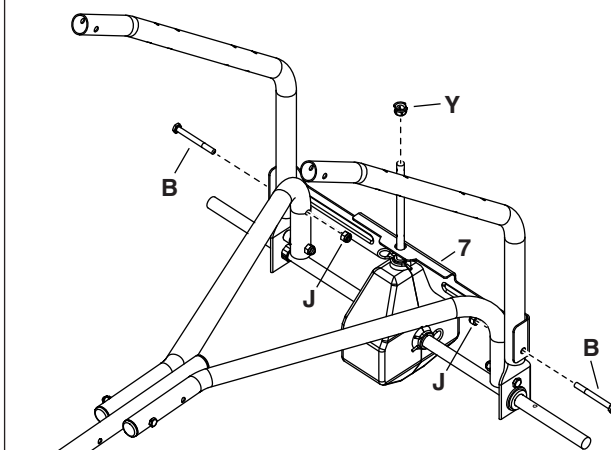

Figure 4

STEP 5: (SEE FIGURE 5)

- Insert plugs (S) into the ends of the hopper support tubes (5).

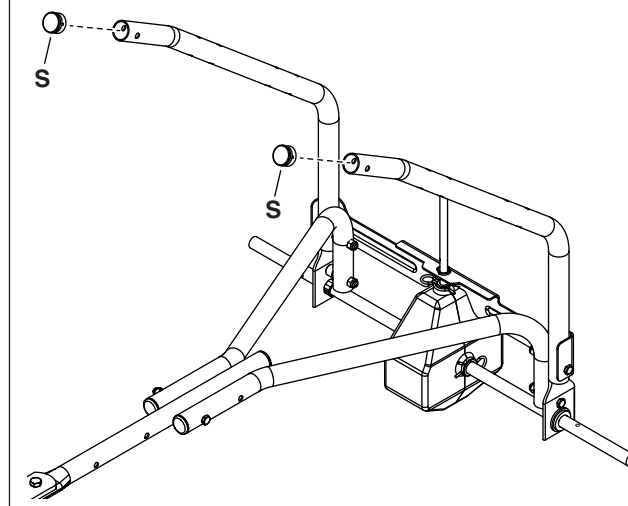

Figure 5

STEP 6: (SEE FIGURE 6)

- Slide the spreader impeller (11) onto the spreader shaft and secure it with a 1/8" x 1-1/2" cotter pin (Q) by spreading the ends of the pin

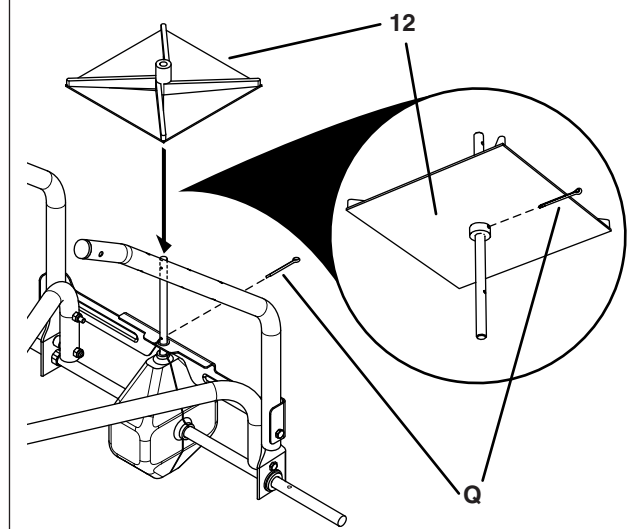

Figure 6

STEP 7: (SEE FIGURE 7)

- Place the hopper on the hopper support tubes, inserting the spreader shaft up through the square hole in the bottom of the hopper.
- Slide the hopper bushing (X) onto the spreader shaft and insert it into the bottom of the hopper.
- Slide the spacer (K) onto the spreader shaft.
- Install the agitator hairpin (I) in the spreader shaft.

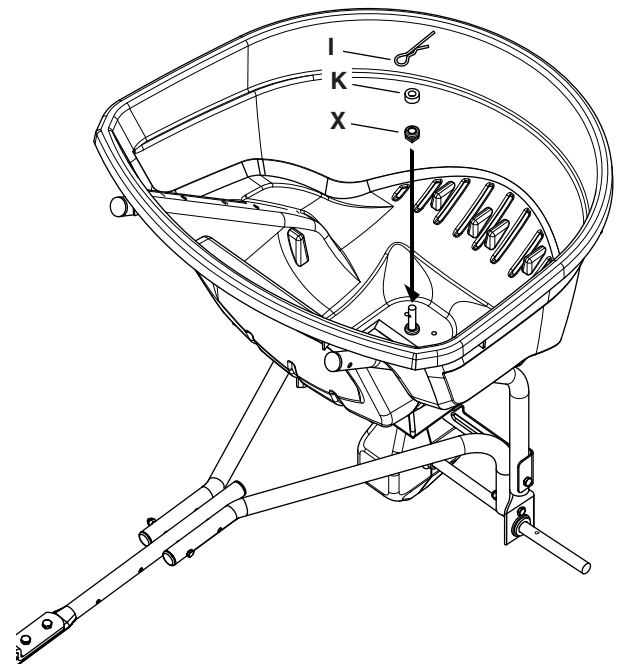

Figure 7

STEP 8: (SEE FIGURE 8)

- Attach the hopper to the upper set of holes in the hopper support tubes using four 1/4" x 1-3/4" hex bolts (D), 1/4" washers (M), nylon washers (N) and 1/4" nylock nuts (J). **Make only finger tight.**

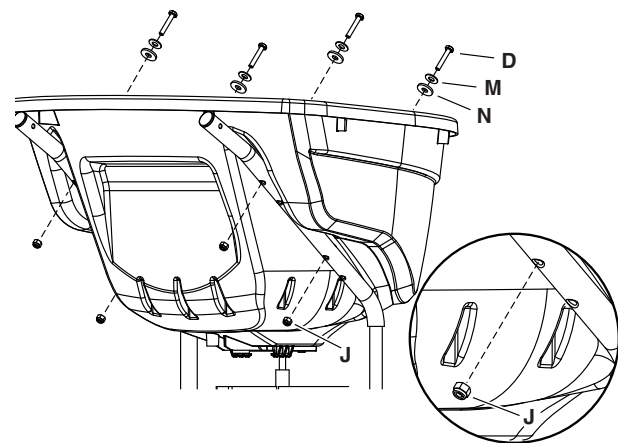

Figure 8

STEP 9: (SEE FIGURE 9)

- Install the grip (T) onto the flow control arm.
- Assemble the adjustable stop (V) to the flow control bracket using the 1/4" x 3/4" carriage bolt (G), nylon washer (N) and wing nut (U).

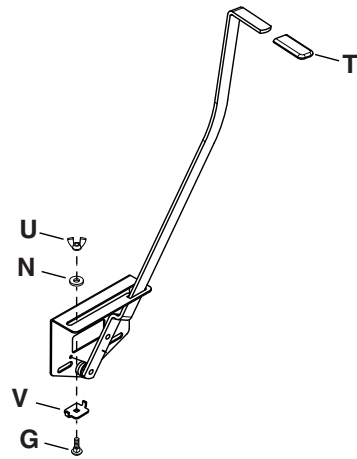

Figure 9

STEP 10: (SEE FIGURE 10)

- Attach the flow control bracket to the hitch tube using two 1/4" x 1-3/4" hex bolts (D), four 1/4" washers (M) and two 1/4" nylock nuts (J). **Do not tighten completely.**

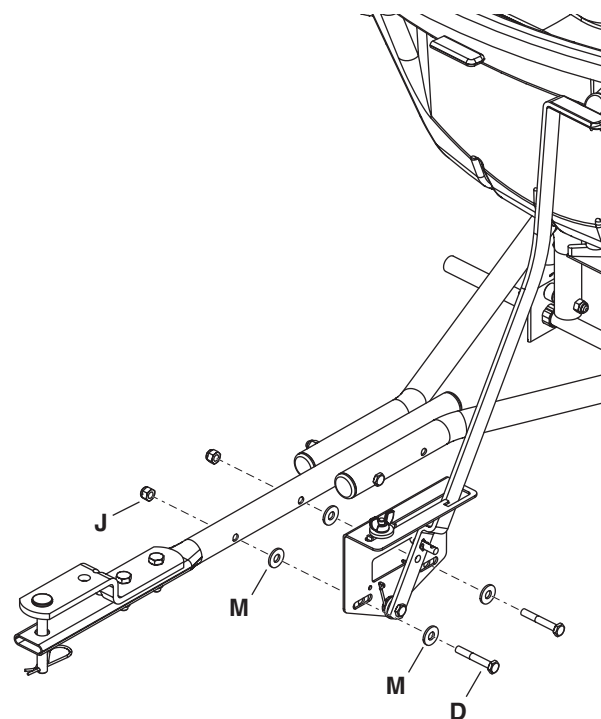

Figure 10

STEP 11: (SEE FIGURE 11)

- Install the end of the flow control rod (9) with no hole into the elongated hole in the flow plate on the bottom of the hopper. Lock the rod in the flow plate by rotating the rod.

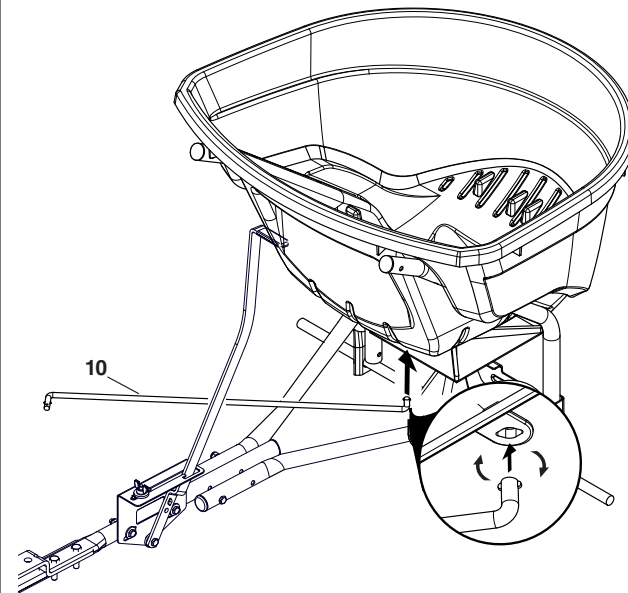

Figure 11

STEP 12: (SEE FIGURE 12)

- Swing the flow control rod around and insert the end of the rod into the flow control arm. Secure it with a 1/4" washer (M) and a 3/32" x 3/4" cotter pin (P).

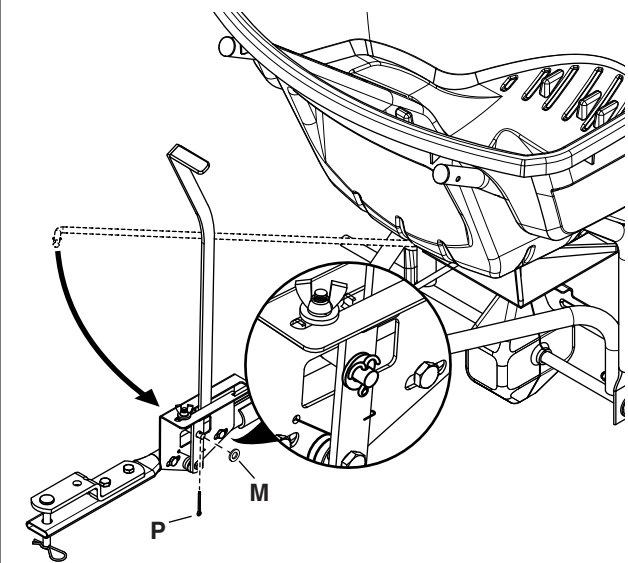

Figure 12

STEP 13: (SEE FIGURE 13)

- Fasten the hopper braces (11) to the hopper support tubes using the nylock nuts (J) that were assembled earlier. **Do not tighten completely.**
- Fasten the loose ends of the hopper braces to the hitch tube using a 1/4" x 3-1/2" hex bolt (F) and a 1/4" nylock nut (J). **Do not tighten completely.**

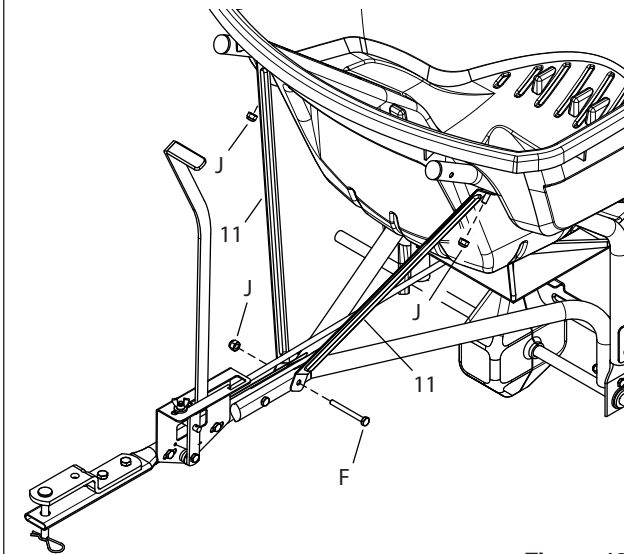

Figure 13

STEP 14:

- **Tighten** all bolts and nuts **except** for those shown in step 9 that fasten the control bracket to the hitch tube.

STEP 15: (SEE FIGURE 14)

- Slide a 5/8" washer (O), a spacer (L), a 5/8" washer (O) and a wheel onto the end of the axle with a hole.
- **Insert a 3/16" x 2" cotter pin (R) into the wheel stud and out through the other end. Spread both ends of the cotter pin.**
- Carefully hammer a hub cap (Z) onto the axle.

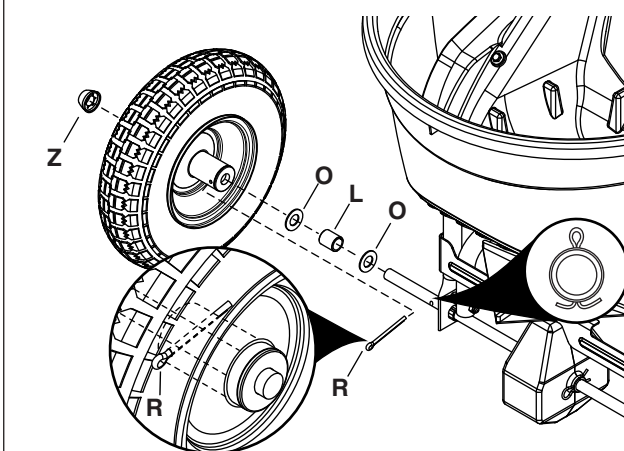

Figure 14

STEP 16: (SEE FIGURE 15)

- Slide a 5/8" washer (O), a spacer (L), a 5/8" washer (O) and a wheel onto the end of the axle with no hole.
- Carefully hammer a hub cap (Z) onto the axle.

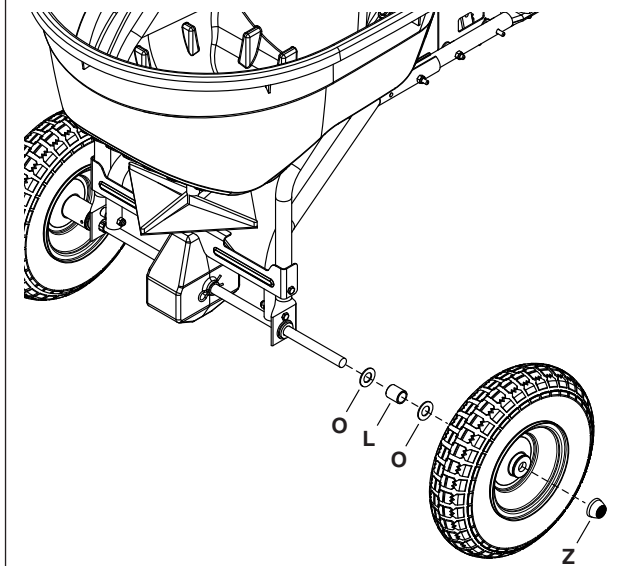

Figure 15

STEP 17: (SEE FIGURE 16)

- Set the adjustable stop at "5" and move the control handle back against it.
- Slide the control bracket along the hitch tube until the flow plate in the bottom of the hopper is open half way.
- **Tighten** the bolts and nuts fastening the control bracket. **Do not deform** the control bracket.
- Make sure the flow plate will open and close all the way. Readjust if necessary.

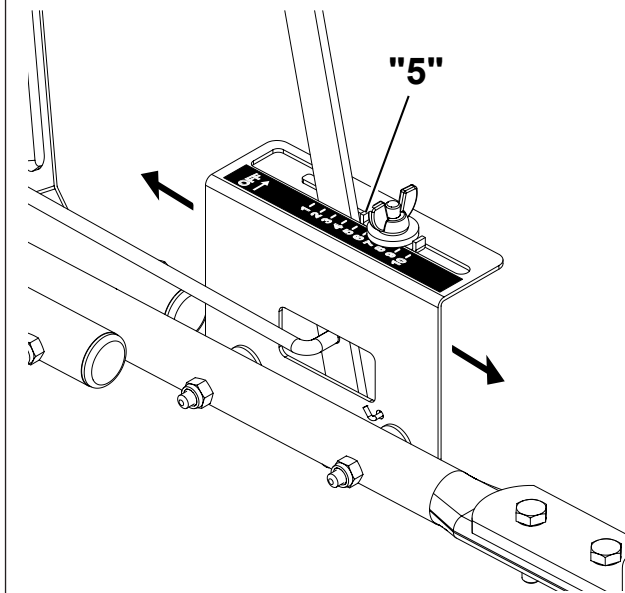

Figure 16