



**RESIDENTIAL & COMMERCIAL
EVAPORATIVE
COOLERS**



EXCEPTIONAL QUALITY
PROVEN RELIABILITY
ENERGY EFFICIENT

WINDOW COOLERS

MCP44

$\frac{1}{3}$ HP Motor
Cools up to 1,600 square feet
4,400 CFM Industry Standard Rating

MCP59

$\frac{1}{2}$ HP Motor
Cools up to 2,000 square feet
5,900 CFM Industry Standard Rating

EASY TO INSTALL AND USES UP TO 75% LESS ENERGY THAN STANDARD AIR CONDITIONING



FEATURES

- Slim 10 Exterior Profile
- 3-Speed Axial Fan
- Weather and UV Resistant Material
- Quiet and Efficient Cooling
- Low Maintenance
- Digital Control with Remote
- 2 Rigid Media Certified to UL Greenguard Standards
- 2-Year Limited Warranty on Motor
- 1-Year Limited Warranty on Unit
- Reduces Temperature by up to 37°F

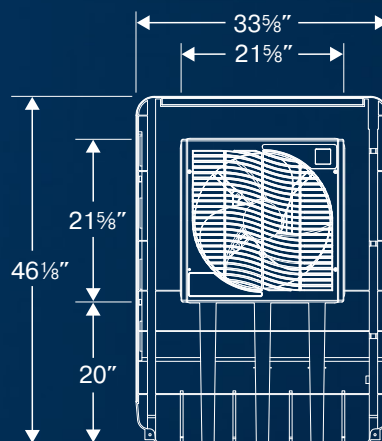

FRONT VIEW

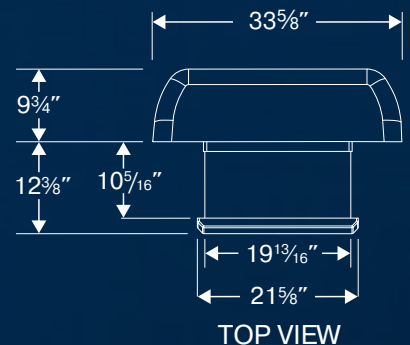

TOP VIEW





ACCESSORIES (SOLD SEPARATELY)



PURGE PUMP KIT MCP44-PPK

Expels water from cooler
Reduces mineral build-up
Extends media life
Carton dimensions (inches):
10 7/8H x 7 3/8W x 5 1/4D



EXTERIOR WINTER COVER MCP44-EC

Keeps cold air out
Weather proof exterior cover
protects unit
Carton dimensions (inches):
11 3/4H x 1 1/8W x 2 7/8D



INTERIOR GRILLE COVER MCP44-IC

Snaps in place over grill
Keeps cold air and dust out
during winter
Carton dimensions (inches):
22 5/8H x 22 3/8W x 5 7/8D



MEDIA REPLACEMENT MCP44-PAD

Double construction
Munters CELdek® rigid media
5-year limited warranty
Carton dimensions (inches):
35 1/2H x 35 1/4W x 2D

SINGLE INLET COOLERS

ADA/ASA/AUA 51

ADA/ASA/AUA 5112

ADA/ASA/AUA 71

ADA/ASA/AUA 7112

1/3, 1/2, or 3/4 HP Motor *sold separately*
Cools up to 1,650 Square Feet

1/3, 1/2, or 3/4 HP Motor *sold separately*
Cools up to 1,650 square feet

1/2, 3/4, or 1 HP Motor *sold separately*
Cools up to 2,300 square feet

1/2, 3/4, or 1 HP Motor *sold separately*
Cools up to 2,300 square feet



FEATURES

- Built in the USA and UL Classified
- Limited Lifetime Warranty on Reservoir
- 1-Year Limited Warranty on Cabinet and Parts
- Uses Munters CELdek® Rigid Media
- Polyester-Resin Coating on Exterior
- Perforated Air Inlet Screen
- Weather and Impact Resistant
- Non-Corrosive Thermoplastic Water Reservoir
- Media is Greenguard Certified



Our high quality, American-made coolers are an economical and environmentally-friendly way to cool up to 2,300 square feet. Engineered for maximum airflow and superior durability, the MasterCool® line of coolers not only saves energy dollars, but also offers years of worry-free cooling comfort for you and your family.

SINGLE INLET COOLERS

1 WATER DISTRIBUTION SYSTEM

PVC tubing and protective housing creates even water flow and distribution to media

2 WET SECTION

Wet section can be separated from blower section for easy field installation

3 MOISTURE SHIELD

Non-metallic barrier to prevent water from coming in contact with the steel cabinet

4 MOTOR

Motor and pulley sold separately

5 JUNCTION BOX

Easily accessible for pump and motor plug-in

6 INSPECTION PANEL

Provides easy access for maintenance and cleaning

7 BLOWER CABINET TOP PANEL

Protects motor from outside moisture

8 CABINET

Strong, galvanized steel electrostatically coated with polyester resin for corrosion resistance

9 BLOWER WHEEL

Designed for quiet operation

10 FLOAT

Easily adjusted brass float arm

11 PUMP

Thermally-protected and UL recognized

12 WATER RESERVOIR

Non-corrosive thermoplastic design

13 MUNTERS CELDEK® RIGID MEDIA

Long-lasting and easy to clean with 5-year limited warranty

14 MESH PREFILTER SCREEN

Allows greater air flow while protecting media

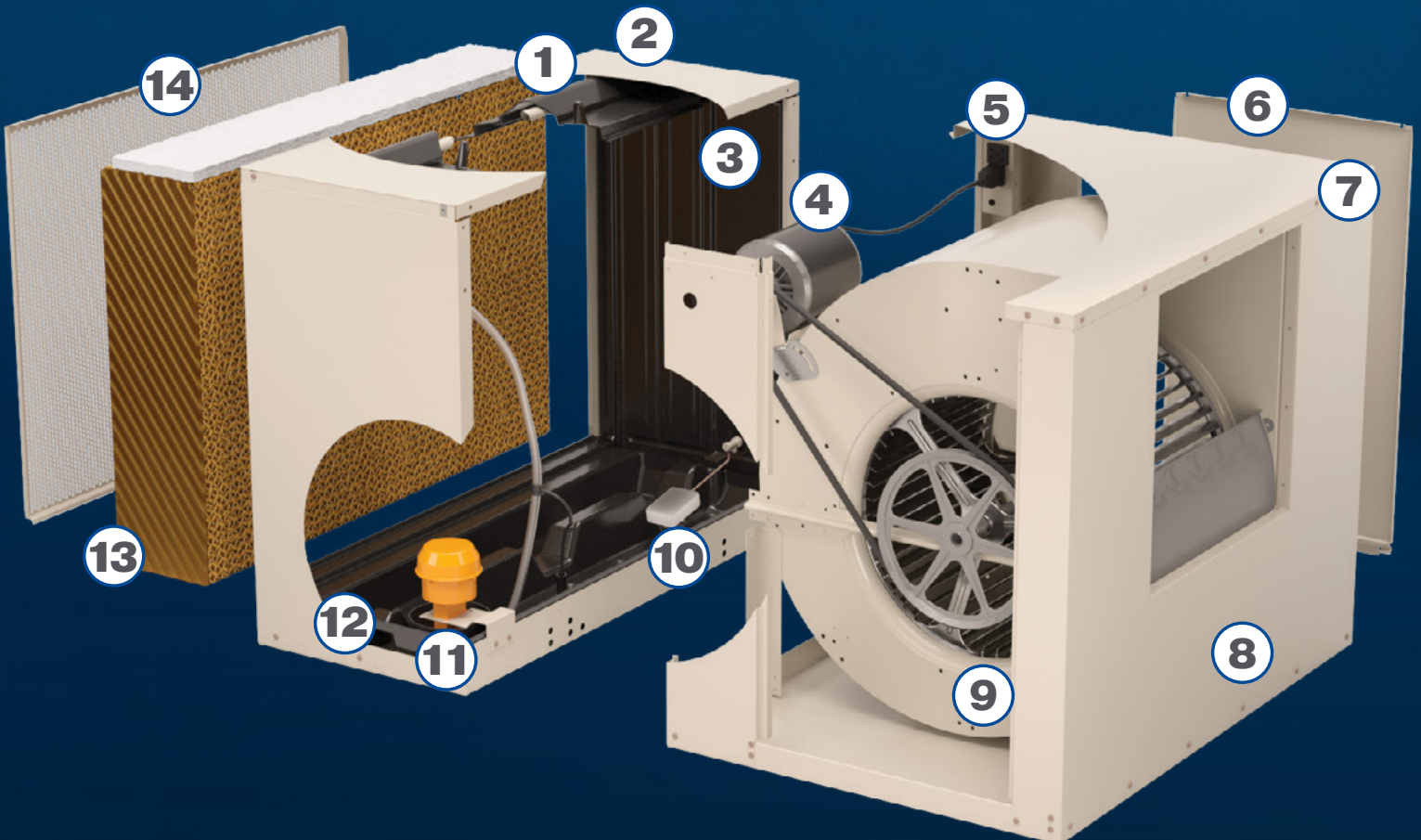

SINGLE INLET - SIDE DRAFT

FRONT

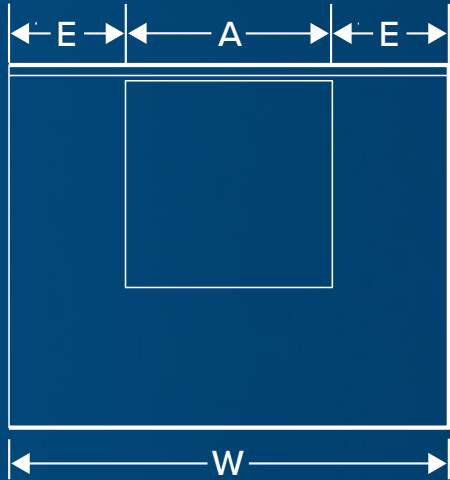

SIDE

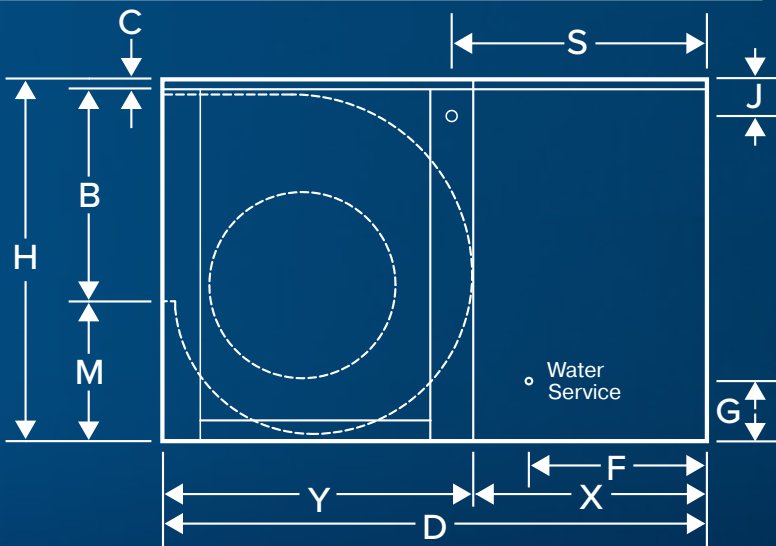

TOP

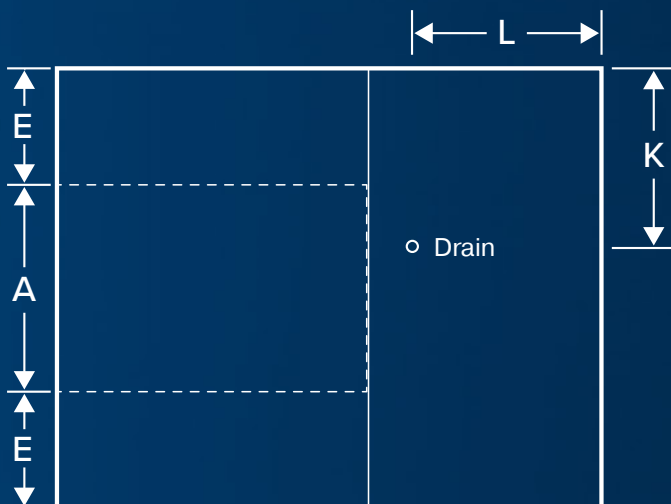

ASA 51 ASA 5112 ASA 71 ASA 7112

OPERATING WEIGHT (LBS)	227	257	263	300
-------------------------------	-----	-----	-----	-----

SHIPPING WEIGHT (LBS)	163	176	193	213
------------------------------	-----	-----	-----	-----

CABINET DIMENSIONS (IN INCHES)

H	28	28	34 5/8	34 5/8
W	42	42	42	42
D	45	49	48	52

DUCT OPENING (IN INCHES)

A	17 3/4	17 3/4	19 3/4	19 3/4
B	17 3/4	17 3/4	19 3/4	19 3/4

DUCT LOCATION (IN INCHES)

C	1 1/2	1 1/2	1 1/2	1 1/2
E	12 1/8	12 1/8	11 1/8	11 1/8
M	8 3/4	8 3/4	13 3/8	13 3/8

WATER SERVICE LOCATION (IN INCHES)

F	13	17	13	17
G	5 3/4	5 3/4	5 3/4	5 3/4

ELECTRICAL SERVICE LOCATION (IN INCHES)

S	20 3/8	24 3/8	20 3/8	24 3/8
J	3 9/16	3 9/16	3 9/16	3 9/16

DRAIN LOCATION (IN INCHES)

K	17	17	17	17
L	14 1/16	18 1/16	14 1/16	18 1/16

MODULE LENGTH (IN INCHES)

X	18 1/4	22 1/4	18 1/4	22 1/4
Y	26 3/4	26 3/4	29 3/4	29 3/4

SHAFT (IN INCHES)

DIAMETER	1	1	1	1
-----------------	---	---	---	---

BLOWER WHEEL (IN INCHES)

DIAMETER	16	16	20	20
WIDTH	16 3/4	16 3/4	16 3/4	16 3/4

MEDIA DIMENSIONS (IN INCHES)

H	22 1/4	22 1/4	28 7/8	28 7/8
W	41 1/4	41 1/4	41 1/4	41 1/4
D	8	12	8	12

ASA51/ASA5112/ASA71/ASA7112

		ASA 51			ASA 5112			ASA 71			ASA 7112		
INDUSTRY STANDARD RATING		4000	4400	5000	4000	4400	5000	5400	6000	7000	5400	6000	7000
COVERAGE UP TO <small>(SQUARE FEET)</small>		1100	1400	1650	1100	1400	1650	1700	2000	2300	1700	2000	2300
MOTOR & PULLEY REQUIREMENTS (SOLD AND SHIPPED SEPARATELY)													
HORSE POWER		1/3	1/2	3/4	1/3	1/2	3/4	1/2	3/4	1	1/2	3/4	1
PULLEY OUTER DIAMETER X BORE <small>(IN INCHES)</small>		3 1/2 x 1/2	4 x 1/2	4 x 1/2	3 1/2 x 1/2	4 x 1/2	4 x 1/2	3 1/2 x 1/2	4 x 1/2	4 x 5/8	3 1/2 x 1/2	4 x 1/2	4 x 5/8
AMPS		8.3	10.9	14.9	8.3	10.9	14.9	10.9	14.9	17.1	10.9	14.9	17.1
INCHES OF STATIC PRESSURE		CUBIC FEET PER MINUTE (CFM)											
0		2873	3321	3788	2750	3149	3606	3987	4564	5024	3922	4488	4941
0.1		2650	3110	3630	2566	2993	3472	3750	4350	4820	3685	4279	4747
0.2		2390	2910	3450	2323	2803	3317	3510	4130	4630	3462	4087	4572
0.3		2060	2650	3260	1997	2564	3135	3270	3940	4450	3212	3888	4394
0.4		1806	2400	3020	1629	2266	2918	3055	3730	4280	2898	3662	4208
0.5		1600	2130	2806	1313	1944	2661	2610	3580	4100	2471	3392	3996
0.6		1370	1940	2570	1039	1648	2379	2210	3180	3900	2002	3049	3749

BELT LENGTH <small>(IN INCHES)</small>												
ASA51	57											
ASA5112	57											
ASA71	67											
ASA7112	67											

*Coverage area depends on outdoor conditions

SINGLE INLET CONTRACTOR LINE

THE SAME SPECIFICATIONS AS THE SINGLE INLET, BUT FULLY ASSEMBLED AND READY TO INSTALL WITH MOTOR, PUMP, PULLEY, PURGE SYSTEM, AND DELUXE THERMOSTAT.

COVERAGE AREA <small>(SQUARE FEET)</small>	MODEL NUMBER	MEDIA THICKNESS <small>(IN INCHES)</small>	MOTOR SPECIFICATIONS		
			HP	SPEED	VOLTS
Up to 1,650	AS1C51 Side Draft	8	3/4	2	115
Up to 1,650	AS2C51 Side Draft	8	3/4	2	230
Up to 1,650	AS1C5112 Side Draft	12	3/4	2	115
Up to 1,650	AS2C5112 Side Draft	12	3/4	2	230
Up to 2,300	AS1C71 Side Draft	8	1	2	115
Up to 2,300	AS2C71 Side Draft	8	1	2	230
Up to 2,300	AS1C7112 Side Draft	12	1	2	115
Up to 2,300	AS2C7112 Side Draft	12	1	2	230

SINGLE INLET - DOWN DRAFT

FRONT

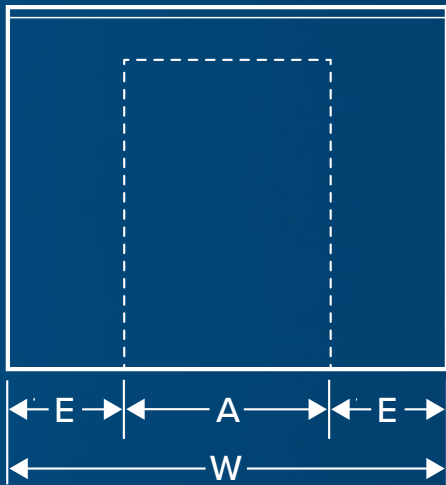

SIDE

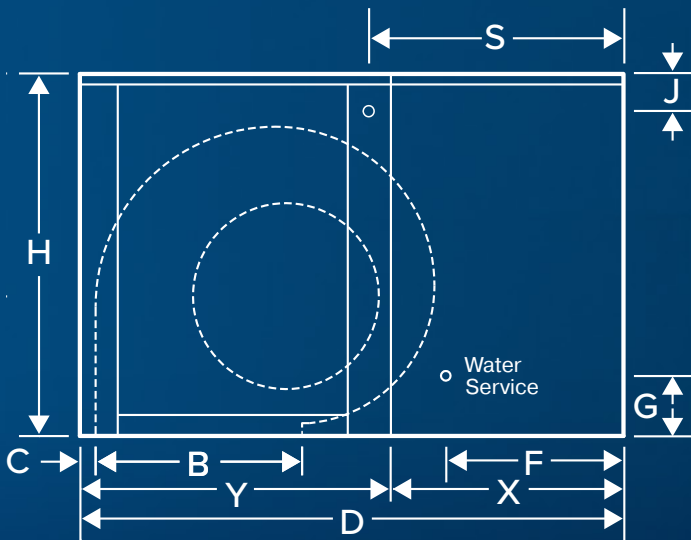

BOTTOM

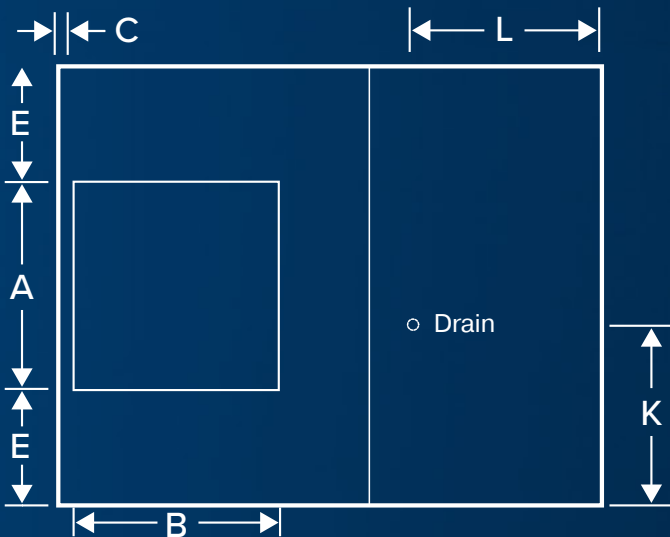

ADA 51 ADA 5112 ADA 71 ADA 7112

OPERATING WEIGHT (LBS)

227	257	263	300
-----	-----	-----	-----

SHIPPING WEIGHT (LBS)

163	176	193	213
-----	-----	-----	-----

CABINET DIMENSIONS (IN INCHES)

H	28	28	34 5/8	34 5/8
W	42	42	42	42
D	45	49	48	52

DUCT OPENING (IN INCHES)

A	17 3/4	17 3/4	19 3/4	19 3/4
B	17 3/4	17 3/4	19 3/4	19 3/4

DUCT LOCATION (IN INCHES)

C	1 1/2	1 1/2	1 1/2	1 1/2
E	12 1/8	12 1/8	11 1/8	11 1/8

WATER SERVICE LOCATION (IN INCHES)

F	13	17	13	17
G	5 3/4	5 3/4	5 3/4	5 3/4

ELECTRICAL SERVICE LOCATION (IN INCHES)

S	20 3/8	24 3/8	20 3/8	24 3/8
J	3 9/16	3 9/16	3 9/16	3 9/16

DRAIN LOCATION (IN INCHES)

K	17	17	17	17
L	14 1/16	18 1/16	14 1/16	18 1/16

MODULE LENGTH (IN INCHES)

X	18 1/4	22 1/4	18 1/4	22 1/4
Y	26 3/4	26 3/4	29 3/4	29 3/4

SHAFT (IN INCHES)

DIAMETER	1	1	1	1
-----------------	---	---	---	---

BLOWER WHEEL (IN INCHES)

DIAMETER	16	16	20	20
WIDTH	16 3/4	16 3/4	16 3/4	16 3/4

MEDIA DIMENSIONS (IN INCHES)

H	22 1/4	22 1/4	28 7/8	28 7/8
W	41 1/4	41 1/4	41 1/4	41 1/4
D	8	12	8	12

ADA51/ADA5112/ADA71/ADA7112

		ADA 51			ADA 5112			ADA 71			ADA 7112		
INDUSTRY STANDARD RATING		4000	4400	5000	4000	4400	5000	5400	6000	7000	5400	6000	7000
COVERAGE UP TO <small>(SQUARE FEET)</small>		1100	1400	1650	1100	1400	1650	1700	2000	2300	1700	2000	2300
MOTOR & PULLEY REQUIREMENTS (SOLD AND SHIPPED SEPARATELY)													
HORSE POWER		1/3	1/2	3/4	1/3	1/2	3/4	1/2	3/4	1	1/2	3/4	1
PULLEY OUTER DIAMETER X BORE <small>(IN INCHES)</small>		3 1/2 x 1/2	4 x 1/2	4 x 1/2	3 1/2 x 1/2	4 x 1/2	4 x 1/2	3 1/2 x 1/2	4 x 1/2	4 x 5/8	3 1/2 x 1/2	4 x 1/2	4 x 5/8
AMPS		8.3	10.9	14.9	8.3	10.9	14.9	10.9	14.9	17.1	10.9	14.9	17.1
INCHES OF STATIC PRESSURE		CUBIC FEET PER MINUTE (CFM)											
0		2873	3321	3788	2750	3149	3606	3987	4564	5024	3922	4488	4941
0.1		2650	3110	3630	2566	2993	3472	3750	4350	4820	3685	4279	4747
0.2		2390	2910	3450	2323	2803	3317	3510	4130	4630	3462	4087	4572
0.3		2060	2650	3260	1997	2564	3135	3270	3940	4450	3212	3888	4394
0.4		1806	2400	3020	1629	2266	2918	3055	3730	4280	2898	3662	4208
0.5		1600	2130	2806	1313	1944	2661	2610	3580	4100	2471	3392	3996
0.6		1370	1940	2570	1039	1648	2379	2210	3180	3900	2002	3049	3749

BELT LENGTH <small>(IN INCHES)</small>	
ADA51	52
ADA5112	52
ADA71	64
ADA7112	64

*3/4 HP requires 53 belt

*Coverage area depends on outdoor conditions

SINGLE INLET CONTRACTOR LINE

THE SAME SPECIFICATIONS AS THE SINGLE INLET, BUT FULLY ASSEMBLED AND READY TO INSTALL WITH MOTOR, PUMP, PULLEY, PURGE SYSTEM, AND DELUXE THERMOSTAT.

COVERAGE AREA <small>(SQUARE FEET)</small>	MODEL NUMBER	MEDIA THICKNESS <small>(IN INCHES)</small>	MOTOR SPECIFICATIONS		
			HP	SPEED	VOLTS
Up to 1,650	AD1C51 Down Draft	8	3/4	2	115
Up to 1,650	AD2C51 Down Draft	8	3/4	2	230
Up to 1,650	AD1C5112 Down Draft	12	3/4	2	115
Up to 1,650	AD2C5112 Down Draft	12	3/4	2	230
Up to 2,300	AD1C71 Down Draft	8	1	2	115
Up to 2,300	AD2C71 Down Draft	8	1	2	230
Up to 2,300	AD1C7112 Down Draft	12	1	2	115
Up to 2,300	AD2C7112 Down Draft	12	1	2	230

SINGLE INLET - UP DRAFT

FRONT

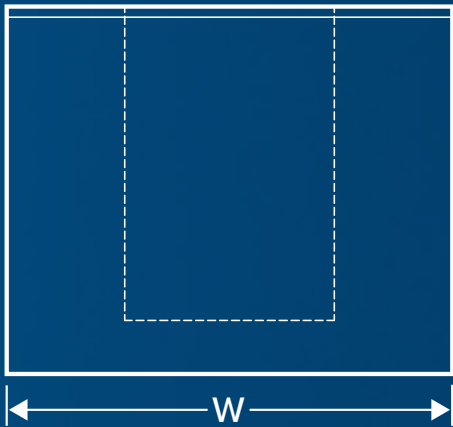

SIDE

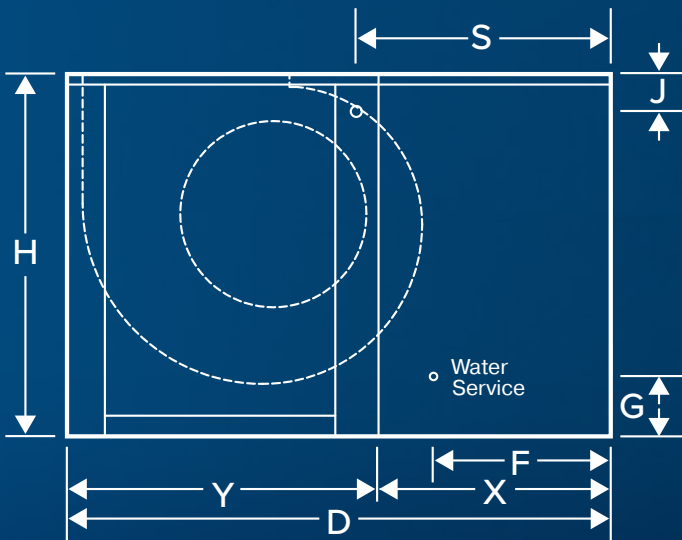

TOP

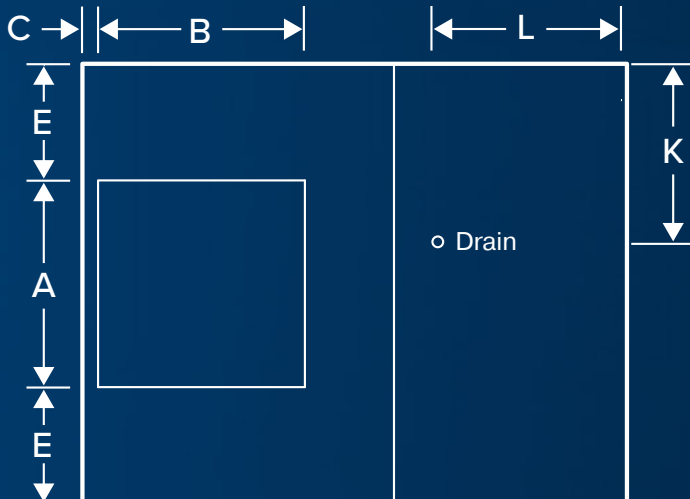

AUA 51 AUA 5112 AUA 71 AUA 7112

OPERATING WEIGHT (LBS)	227	257	263	300
SHIPPING WEIGHT (LBS)	163	176	193	213

CABINET DIMENSIONS (IN INCHES)

H	28	28	34 5/8	34 5/8
W	42	42	42	42
D	45	49	48	52

DUCT OPENING (IN INCHES)

A	17 3/4	17 3/4	19 3/4	19 3/4
B	17 3/4	17 3/4	19 3/4	19 3/4

DUCT LOCATION (IN INCHES)

C	1 1/2	1 1/2	1 1/2	1 1/2
E	12 1/8	12 1/8	11 1/8	11 1/8

WATER SERVICE LOCATION (IN INCHES)

F	13	17	13	17
G	5 3/4	5 3/4	5 3/4	5 3/4

ELECTRICAL SERVICE LOCATION (IN INCHES)

S	20 3/8	24 3/8	20 3/8	24 3/8
J	3 9/16	3 9/16	3 9/16	3 9/16

DRAIN LOCATION (IN INCHES)

K	17	17	17	17
L	14 1/16	18 1/16	14 1/16	18 1/16

MODULE LENGTH (IN INCHES)

X	18 1/4	22 1/4	18 1/4	22 1/4
Y	26 3/4	26 3/4	29 3/4	29 3/4

SHAFT (IN INCHES)

DIAMETER	1	1	1	1
-----------------	---	---	---	---

BLOWER WHEEL (IN INCHES)

DIAMETER	16	16	20	20
WIDTH	16 3/4	16 3/4	16 3/4	16 3/4

MEDIA DIMENSIONS (IN INCHES)

H	22 1/4	22 1/4	28 7/8	28 7/8
W	41 1/4	41 1/4	41 1/4	41 1/4
D	8	12	8	12

AUA51/AUA5112/AUA71/AUA7112

		AUA 51			AUA 5112			AUA 71			AUA 7112		
INDUSTRY STANDARD RATING		4000	4400	5000	4000	4400	5000	5400	6000	7000	5400	6000	7000
COVERAGE UP TO (SQUARE FEET)		1100	1400	1650	1100	1400	1650	1700	2000	2300	1700	2000	2300
MOTOR & PULLEY REQUIREMENTS (SOLD AND SHIPPED SEPARATELY)													
HORSE POWER		1/3	1/2	3/4	1/3	1/2	3/4	1/2	3/4	1	1/2	3/4	1
PULLEY OUTER DIAMETER X BORE (IN INCHES)		3 1/2 x 1/2	4 x 1/2	4 x 1/2	3 1/2 x 1/2	4 x 1/2	4 x 1/2	3 1/2 x 1/2	4 x 1/2	4 x 5/8	3 1/2 x 1/2	4 x 1/2	4 x 5/8
AMPS		8.3	10.9	14.9	8.3	10.9	14.9	10.9	14.9	17.1	10.9	14.9	17.1
INCHES OF STATIC PRESSURE		CUBIC FEET PER MINUTE (CFM)											
0		2873	3321	3788	2750	3149	3606	3987	4564	5024	3922	4488	4941
0.1		2650	3110	3630	2566	2993	3472	3750	4350	4820	3685	4279	4747
0.2		2390	2910	3450	2323	2803	3317	3510	4130	4630	3462	4087	4572
0.3		2060	2650	3260	1997	2564	3135	3270	3940	4450	3212	3888	4394
0.4		1806	2400	3020	1629	2266	2918	3055	3730	4280	2898	3662	4208
0.5		1600	2130	2806	1313	1944	2661	2610	3580	4100	2471	3392	3996
0.6		1370	1940	2570	1039	1648	2379	2210	3180	3900	2002	3049	3749

BELT LENGTH (IN INCHES)	
AUA51	51
AUA5112	51
AUA71	67
AUA7112	67

*Coverage area depends on outdoor conditions

SINGLE INLET CONTRACTOR LINE

THE SAME SPECIFICATIONS AS THE SINGLE INLET, BUT FULLY ASSEMBLED AND READY TO INSTALL WITH MOTOR, PUMP, PULLEY, PURGE SYSTEM, AND DELUXE THERMOSTAT.

COVERAGE AREA (SQUARE FEET)	MODEL NUMBER	MEDIA THICKNESS (IN INCHES)	MOTOR SPECIFICATIONS		
			HP	SPEED	VOLTS
Up to 2,300	AU1C7112 Up Draft	12	1	2	115
Up to 2,300	AU2C7112 Up Draft	12	1	2	230

COMMERCIAL & INDUSTRIAL COOLERS

AS/AD 100

SAS/SAD 100

AS/AD 10012

SAS/SAD 10012

AS/AD 150

SAS/SAD 150

AS/AD 15012

SAS/SAD 15012

AS/AD/AU 20012



FEATURES

- Heavy-Gauge Galvanized Steel Used for Cabinet and Other Load-Bearing Components
- Non-Corrosive ABS Plastic Water Reservoir
- Limited Lifetime Warranty on Reservoir
- 1-Year Limited Warranty on Cabinet and Parts
- Uses Munters CELdek® Rigid Media
- Electrostatically Applied Polyester-Resin Finish to Protect Against Corrosion



Standard units use Munters CELdek® media and are UL Listed only for installations with duct supplying air to a single room, area, or space.

For installations with duct supplying air to multiple rooms or areas, the use of Munters GLASdek® media is required. For these units add the 'UL' suffix to the standard model number when ordering.



Champion Cooler Corporation certifies that the evaporative air coolers shown herein are licensed to bear the AMCA seal. The ratings shown are based on tests and procedures performed in accordance with AMCA publication 211 and comply with the requirements of the AMCA certified ratings program.

The following chart's dimensional data measurements are in inches. The performance certified is for installation type B-Free inlet, ducted outlet. The power rating (BHP) does not include transmission losses. Performance ratings do not include the effects of appurtenances (accessories). Models include the effects of an appropriate evaporative media on the inlet. When the Cooler Model #, Motor HP, & Blower Speed are determined from the SPECIFICATION table, use this information to select the proper pulley-belt kit from the SHEAVE SELECTION table. Amperage shown is from National Electrical Code. Use amperage shown on motor nameplate to determine motor protector. When selecting motor, be sure to select Pulley-Belt Kit with same pulley bore as shaft size of motor selected. Static Pressure (SP) is measured by inches of water gauge. GPH is used for water consumption at design conditions, but does not include bleed-off amount. Amount of bleed-off will vary with different water sources, but an amount equal to 10% of water consumption at any design condition sufficient for average water. The acronym LAT defines the cooler discharge temperature.

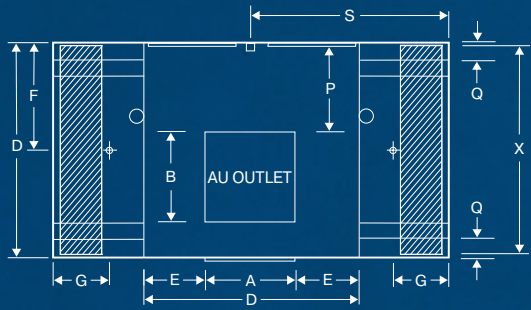

TOP

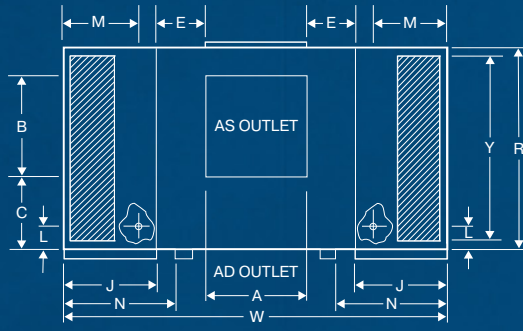

FRONT

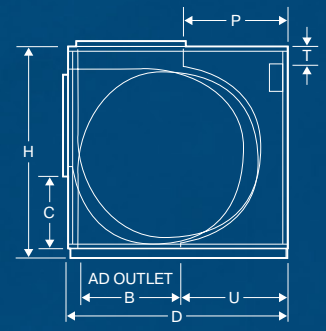

SIDE

DIMENSIONAL DATA (IN INCHES)

CABINET			DUCT OPENING			DUCT LOCATION			DRAIN LOCATION			WET MODULE		MEDIA DIMENSIONS		WATER SERVICE		ELECTRIC SERVICE		SOLID LOCATION		
H	W	D	A	B	C (AS)	U (AD)	P (AD)	E	F	G	J	X	Y	L	M	S	T	N	Q	R		
44	82	45	21 3/4	21 3/4	13 1/2	21 1/2	-	11 5/8	22 1/2	12 1/2	18 1/2	44 3/4	36 3/8	5 7/8	14 3/8	39 7/8	5 1/2	23 1/4	4 3/8	42		

PUMP SPECIFICATIONS/BLOWER & WET MODULE PART NUMBERS

PUMP PART #	VOLTS	AMPS	WATTS	GPM (5 FOOT HEAD)	SIDE DRAFT BLOWER MODULE		DOWN DRAFT BLOWER MODULE		WET MODULE	
					AS100B	AD100B	AS/AD100W (two pumps required)			
110467	115	1	73	4.6						
110468	230	0.58	77	4.6						

SPECIFICATIONS

PERFORMANCE Certified air delivery at .1 Increments of external static pressure (inches static pressure water gauge)

MAX BHP	OPER WGT (LBS)	AD MODEL BELT	AS MODEL BELT	0		0.1		0.2		0.3		0.4		0.5		0.6		0.7		0.8		0.9		1.0	
				CFM	RPM	CFM	RPM	CFM	RPM	CFM	RPM	CFM	RPM	CFM	RPM	CFM	RPM	CFM	RPM	CFM	RPM	CFM	RPM	CFM	RPM
1 1/2	706	A76	A82	7431	391	7323	398	7132	407	6917	416	6680	427	6424	439	6165	451	5897	463	5623	476	5345	490	5054	505
2	710	B77	B83	8231	430	8095	436	7926	444	7740	452	7536	462	7317	472	7088	482	6850	493	6608	505	6360	516	6110	528
3	723	B80	B86	9422	493	9309	498	9169	504	9014	511	8849	518	8670	527	8481	535	8286	544	8084	553	7879	563	7666	573
5	739	B81	B87	11170	584	11082	588	10970	593	10848	599	10718	604	10581	611	10435	617	10284	624	10128	631	9966	639	9798	646

The performance certified is for installation type B-Free inlet, ducted outlet. The power rating (BHP) does not include transmission losses. Performance ratings do not include the effects of appurtenances (accessories). Models include the effects of an appropriate evaporative media on the inlet.

MOTOR SPECIFICATIONS

BLOWER MOTORS				BLOWER MOTORS											
HP	SPEED	VOLTS	PHASE	MOTOR AMPS	SHAFT DIA (INCHES)	MOTOR WGT (LBS)	MOTOR PART	HP	SPEED	VOLTS	PHASE	MOTOR AMPS	SHAFT DIA (INCHES)	MOTOR WGT (LBS)	MOTOR PART
1 1/2	1	115/208-230	1	20/11-10	5/8	41	110459-1	2	1	208 - 230/460	3	7.8-6.8/3.4	7/8	44	110464-9
1 1/2	1	208-230/460	3	6.9-6/3	7/8	40	110463-9	3	1	208 - 230/460	3	11-9.6/4.8	1 1/8	83	110465-9
2	1	115/208-230	1	24/13.2-12	5/8	49	110460-1	5	1	208 - 230/460	3	17.5-15.2/7.6	1 1/8	87	110466-9

SHEAVE SELECTION

MOTOR HP	MAUREY SHEAVE	SHEAVE BORE (IN INCHES)	AD MODEL BELT	AS MODEL BELT	BLOWER RPM/MOTOR SHEAVE 1/2 TURN DOWN (IN INCHES)												AD PULLEY-BELT KIT #	AS PULLEY-BELT KIT #
					12	11	10	9	8	7	6	5	4	3	2	1		
1 1/2	D8450	5/8	A76	A82	391	401	412	422	433	443	454	464	475	485	496	506	3DI-11	3DI-31
1 1/2	D8450	7/8	A76	A82	391	401	412	422	433	443	454	464	475	485	496	506	3DI-10	3DI-30
2	D8450	5/8	B77	B83	414	424	434	445	455	465	475	485	495	506	516	526	3DI-16	3DI-36
2	D8450	7/8	B77	B83	414	424	434	445	455	465	475	485	495	506	516	526	3DI-15	3DI-35
3	D8550	1 1/8	B80	B86	482	492	502	513	523	533	543	553	563	574	584	594	3DI-20	3DI-40
5	D8600	1 1/8	B81	B87	549	559	569	580	590	600	610	620	630	641	651	661	3DI-25	3DI-45

SIZING TABLES

OUTDOOR DRY BULB TEMP	1 1/2 HP MOTOR/CFM-SP									2 HP MOTOR/CFM-SP									3 HP MOTOR/CFM-SP									5 HP MOTOR/CFM-SP									
	7478/0			6424/.5			5054/1.0			8231/0			7317/.5			6110/1.0			9422/0			8670/.5			7666/1.0			11170/0			10581/.5			9798/1.0			
	75°	65°	55°	75°	65°	55°	75°	65°	55°	75°	65°	55°	75°	65°	55°	75°	65°	55°	75°	65°	55°	75°	65°	55°	75°	65°	55°	75°	65°	55°	75°	65°	55°				
85°	LAT	77	69	60	77	68	60	76	68	59	77	69	61	77	69	60	77	68	60	77	69	61	77	69	61	77	69	60	77	69	62	77	69	61	77	69	61
	GPH	7	15	22	6	13	19	5	10	15	8	16	24	7	14	21	6	12	18	9	19	28	9	17	25	8	15	23	11	22	33	10	21	31	10	19	29
95°	LAT	79	70	62	78	70	61	78	69	60	79	71	62	79	70	62	78	69	61	79	71	63	79	71	63	79	70	62	79	72	64	79	71	63	79	71	63
	GPH	15	22	29	13	19	25	10	15	20	16	24	32	14	22	29	12	18	24	19	28	37	17	26	34	15	23	30	22	33	44	21	31	41	19	29	38
105°	LAT	80	72	-	80	71	-	79	71	-	81	74	-	80	72	-	79	71	-	81	73	-	81	73	-	80	72	-	82	74	-	81	73	-	81	73	-
	GPH	22	29	-	19	25	-	15	20	-	22	29	-	18	24	-	28	37	-	26	34	-	23	30	-	33	44	-	31	42	-	29	39	-			
115°	LAT	82	74	-	81	73	-	80	72	-	82	74	-	82	74	-	81	72	-	83	75	-	83	74	-	82	74	-	84	76	-	83	75	-	83	75	-
	GPH	30	37	-	25	32	-	20	25	-	33	40	-	29	36	-	24	30	-	37	46	-	34	43	-	30	38	-	44	55	-	42	52	-	39	48	-

SAS/SAD 100

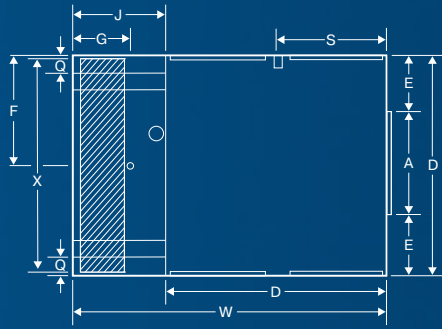

TOP

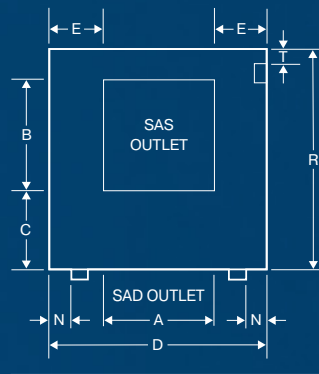

FRONT

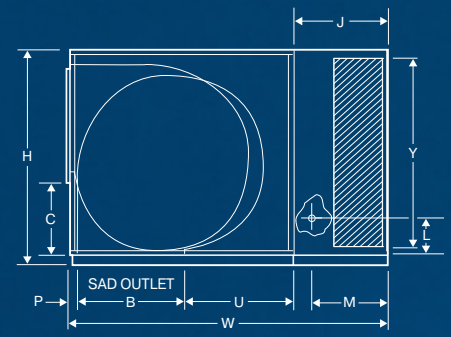

SIDE

DIMENSIONAL DATA (IN INCHES)

CABINET			DUCT OPENING			DUCT LOCATION			DRAIN LOCATION			WET MODULE	MEDIA DIMENSIONS		WATER SERVICE		ELECTRIC SERVICE		SOLID LOCATION		
H	W	D	A	B	C (SAS)	U (SAD)	P (SAD)	E	F	G	J	X	Y	L	M	S	T	N	Q	R	
44	63 3/4	45	21 3/4	21 3/4	13 19/32	21 11/32	1 29/32	11 5/8	22 1/2	12 1/2	18 1/2	44 3/4	36 3/8	5 7/8	14 3/8	12 1/2	5 5/32	4 3/4	4 3/4	42	

PUMP SPECIFICATIONS/BLOWER & WET MODULE PART NUMBERS

PUMP PART #	VOLTS	AMPS	WATTS	GPM (5FT. HEAD)	SIDE DRAFT BLOWER MODULE	DOWN DRAFT BLOWER MODULE	WET MODULE
110467	115	1	73	4.6	SAS100B	SAD100B	SAS/SAD100W (one pump required)
110468	230	0.58	77	4.6			

SPECIFICATIONS

PERFORMANCE Certified air delivery at .1 increments of external static pressure (inches static pressure water gauge)

MAX BHP	OPER WGT (LBS)	AD MODEL BELT	AS MODEL BELT	0		0.1		0.2		0.3"		0.4		0.5		0.6		0.7		0.8		0.9"		1.0	
				CFM	RPM	CFM	RPM	CFM	RPM	CFM	RPM	CFM	RPM	CFM	RPM	CFM	RPM	CFM	RPM	CFM	RPM	CFM	RPM	CFM	RPM
3/4	480	B77	B83	5377	352	5121	364	4863	376	4605	389	4336	402	4058	415	3754	430	3429	448	3097	469	-	-	-	-
1	483	B77	B83	5918	388	5684	398	5451	409	5215	421	4980	432	4734	444	4479	456	4209	470	3924	485	3619	503	3307	523
1 1/2	498	B77	B83	6774	444	6574	453	6366	463	6164	472	5956	482	5751	492	5537	502	5320	513	5095	524	4859	536	4613	548

The performance certified is for installation type B-Free inlet, ducted outlet. The power rating (BHP) does not include transmission losses. Performance ratings do not include the effects of appurtenances (accessories). Models include the effects of an appropriate evaporative media on the inlet.

MOTOR SPECIFICATIONS

BLOWER MOTORS								BLOWER MOTORS							
HP	SPEED	VOLTS	PHASE	MOTOR AMPS	SHAFT DIA (INCHES)	MOTOR WGT (LBS)	MOTOR PART	HP	SPEED	VOLTS	PHASE	MOTOR AMPS	SHAFT DIA (INCHES)	MOTOR WGT (LBS)	MOTOR PART
3/4	1	115/208-230	1	13.8/7.6-6.9	5/8	24	110455	1	2	230	1	8	5/8	29	110458
3/4	2	230	1	6.9	5/8	29	110480	1	1	208-230/460	3	4.8-4.2/2.1	7/8	34	110462-9
3/4	1	208-230/460	3	3.5-3.2/1.6	5/8	20	110461	1 1/2	1	115/208-230	3	20/11-10	5/8	41	110459-1
1	1	115/230	1	16/8	5/8	28	110457	1 1/2	1	208-230-460	3	6.9-6/3	7/8	40	110463-9

SHEAVE SELECTION

MOTOR HP	MAUREY SHEAVE	SHEAVE BORE (IN INCHES)	SAD MODEL BELT	SAS MODEL BELT	BLOWER RPM/MOTOR SHEAVE 1/2 TURN DOWN												SAD PULLEY-BELT KIT #	SAS PULLEY-BELT KIT #
					12	11	10	9	8	7	6	5	4	3	2	1		
3/4, 1	8350K	5/8	B77	B83	303	313	323	333	343	353	364	374	384	394	404	414	3DI-90	3DI-110
3/4, 1, 1 1/2	8450K	5/8	B77	B83	414	424	434	445	455	465	475	485	495	506	516	526	3DI-95	3DI-115
1	8350K	7/8	B77	B83	303	313	323	333	343	353	364	374	384	394	404	414	3DI-100	3DI-120
1, 1 1/2	8450K	7/8	B77	B83	414	424	434	445	455	465	475	485	495	506	516	526	3DI-105	3DI-125

SIZING TABLES

3/4 HP MOTOR/CFM-SP

1 HP MOTOR/CFM-SP

1 1/2 HP MOTOR/CFM-SP

OUTDOOR DRY BULB TEMP	OUTDOOR WET BULB TEMP																											
	5377/0			4058/.5			3097/.8			5918/0			4734/.5			3307/1.0			6774/0			5751/.5			4613/1.0			
	75°	65°	55°	75°	65°	55°	75°	65°	55°	75°	65°	55°	75°	65°	55°	75°	65°	55°	75°	65°	55°	75°	65°	55°	75°	65°	55°	
85°	LAT	77	69	61	77	69	60	76	67	59	77	69	62	77	69	61	77	68	60	77	70	62	77	69	61	77	69	61
	GPH	5	10	15	4	8	12	3	6	9	6	11	17	5	9	14	3	7	10	6	13	19	6	11	17	5	9	13
95°	LAT	79	71	63	79	70	62	77	69	60	79	72	64	79	71	63	78	70	61	80	72	64	79	71	64	79	70	63
	GPH	10	15	21	8	12	16	6	9	12	11	17	22	9	14	19	7	10	13	13	19	25	11	17	22	9	13	18
105°	LAT	81	73	-	80	72	-	79	70	-	82	74	-	81	73	-	80	71	-	82	74	-	81	74	-	81	73	-
	GPH	15	21	-	12	16	-	9	12	-	17	22	-	14	19	-	10	13	-	19	25	-	17	22	-	13	18	-
115°	LAT	83	75	-	82	74	-	80	72	-	84	76	-	83	75	-	81	73	-	84	77	-	84	76	-	83	75	-
	GPH	21	26	-	16	21	-	12	15	-	22	28	-	19	23	-	13	16	-	25	32	-	22	28	-	18	22	-

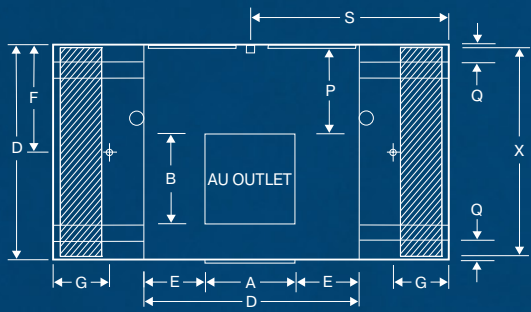

TOP

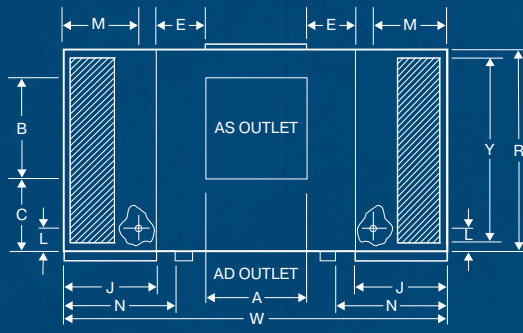

FRONT

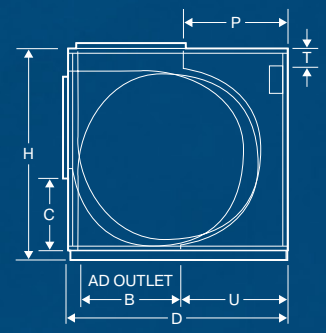

SIDE

DIMENSIONAL DATA (IN INCHES)

CABINET			DUCT OPENING		DUCT LOCATION			DRAIN LOCATION		WET MODULE	MEDIA DIMENSIONS		WATER SERVICE		ELECTRIC SERVICE		SOLID LOCATION			
H	W	D	A	B	C (AS)	U (AD)	P (AU)	E	F	G	J	X	Y	L	M	S	T	N	Q	R
44	90	45	21¾	21¾	13 ¹⁹ / ₃₂	21 ¹¹ / ₃₂	-	11%	22 ½	16½	22½	44¾	36%	5 ⁷ / ₁₆	18%	43 ⁷ / ₁₆	5 ⁵ / ₁₆	27¼	4¾	42

PUMP SPECIFICATIONS/BLOWER & WET MODULE PART NUMBERS

PUMP PART #	VOLTS	AMPS	WATTS	GPM (5FT. HEAD)	SIDE DRAFT BLOWER MODULE		DOWN DRAFT BLOWER MODULE		WET MODULE	
					AS100B	AD100B	AS/AD10012W (two pumps required)			
110467	115	1	73	4.6						
110468	230	0.58	77	4.6						

SPECIFICATIONS

PERFORMANCE Certified air delivery at .1 increments of external static pressure (inches static pressure water gauge)

MAX BHP	OPER WGT (LBS)	AD MODEL BELT	AS MODEL BELT	PERFORMANCE																							
				0		0.1		0.2		0.3		0.4		0.5		0.6		0.7		0.8		0.9"		1.0			
				CFM	RPM	CFM	RPM	CFM	RPM	CFM	RPM	CFM	RPM	CFM	RPM	CFM	RPM	CFM	RPM	CFM	RPM	CFM	RPM	CFM	RPM	CFM	RPM
1½	801	A76	A82	7431	382	7255	390	7052	400	6835	411	6611	424	6376	437	6131	450	5877	464	5610	477	5327	492	5031	507		
2	805	B77	B83	8178	421	8024	427	7842	436	7649	446	7450	457	7244	468	7030	480	6809	492	6580	504	6343	517	6095	529		
3	818	B80	B86	9362	482	9235	487	9075	494	8914	502	8744	511	8572	520	8393	531	8209	541	8024	551	7827	562	7631	672		
5	834	B81	B87	11099	571	11001	575	10868	581	10736	587	10598	594	10457	601	10313	609	10165	617	10016	625	9862	634	9709	643		

The performance certified is for installation type B-Free inlet, ducted outlet. The power rating (BHP) does not include transmission losses. Performance ratings do not include the effects of appurtenances (accessories). Models include the effects of an appropriate evaporative media on the inlet.

MOTOR SPECIFICATIONS

BLOWER MOTORS								BLOWER MOTORS							
HP	SPEED	VOLTS	PHASE	MOTOR AMPS	SHAFT DIA (INCHES)	MOTOR WGT (LBS)	MOTOR PART	HP	SPEED	VOLTS	PHASE	MOTOR AMPS	SHAFT DIA (INCHES)	MOTOR WGT (LBS)	MOTOR PART
1½	1	115/208 - 230	1	20/11-10	5/8	41	110459-1	2	1	208 - 230/460	3	7.8-6.8/3.4	7/8	44	110464-9
1½	1	208 - 230/460	3	6.9-6/3	7/8	40	110463-9	3	1	208 - 230/460	3	11-9.6/4.8	1	83	110465-9
2	1	115/208 - 230	1	24/13.2-12	5/8	49	110460-1	5	1	208 - 230/460	3	17.5-15.2/7.6	1	87	110466-9

SHEAVE SELECTION

MOTOR HP	MAUREY SHEAVE	SHEAVE BORE (IN INCHES)	AD MODEL BELT	AS MODEL BELT	BLOWER RPM/MOTOR SHEAVE ½ TURN DOWN												AD PULLEY-BELT KIT #	AS PULLEY-BELT KIT #
					12	11	10	9	8	7	6	5	4	3	2	1		
1½	D8450	5/8	A76	A82	391	401	412	422	433	443	454	464	475	485	496	506	3DI-11	3DI-31
1½	D8450	7/8	A76	A82	391	401	412	422	433	443	454	464	475	485	496	506	3DI-10	3DI-30
2	D8450	5/8	B77	B83	414	424	434	445	455	465	475	485	495	506	516	526	3DI-16	3DI-36
2	D8450	7/8	B77	B83	414	424	434	445	455	465	475	485	495	506	516	526	3DI-15	3DI-35
3	D8550	1	B80	B86	482	492	502	513	523	533	543	553	563	574	584	594	3DI-20	3DI-40
5	D8600	1	B81	B87	549	559	569	580	590	600	610	620	630	641	651	661	3DI-25	3DI-45

SIZING TABLES

OUTDOOR DRY BULB TEMP	1 ½ HP MOTOR/CFM-SP					2 HP MOTOR/CFM-SP					3 HP MOTOR/CFM-SP					5 HP MOTOR/CFM-SP									
	7431/0		6376/.5		5031/1.0		8178/0		7244/.5		6095/1.0		9362/0		8572/.5		7631/1.0		11099/0		10457/.5		9709/1.0		
	75°	65°	55°	75°	65°	55°	75°	65°	55°	75°	65°	55°	75°	65°	55°	75°	65°	55°	75°	65°	55°	75°	65°	55°	
85°	LAT	76	67	58	76	67	58	76	67	58	76	67	58	76	67	58	76	67	58	76	67	58	76	67	58
	GPH	8	17	25	7	14	21	6	11	17	9	18	28	8	16	24	7	13	20	11	21	32	9	19	28
95°	LAT	77	68	59	77	68	59	77	68	59	77	68	59	77	68	59	77	68	59	77	68	59	77	68	59
	GPH	17	25	34	14	21	28	11	17	22	18	28	37	16	24	32	13	20	27	21	32	42	19	28	38
105°	LAT	78	69	-	78	69	-	77	68	-	78	69	-	78	69	-	78	69	-	78	69	-	78	69	-
	GPH	25	34	-	21	28	-	17	22	-	28	37	-	24	32	-	20	27	-	32	42	-	28	38	-
115°	LAT	79	70	-	79	70	-	78	69	-	79	70	-	79	70	-	79	70	-	79	70	-	79	70	-
	GPH	34	42	-	28	35	-	22	28	-	37	46	-	32	40	-	27	33	-	42	53	-	38	47	-

SAS/SAD 10012

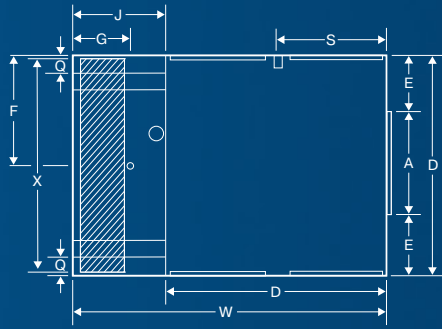

TOP

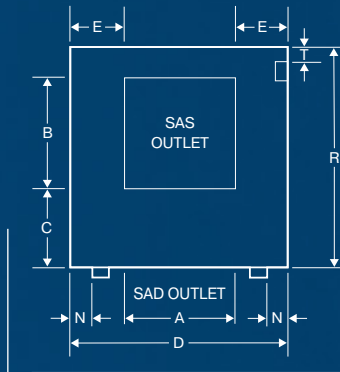

FRONT

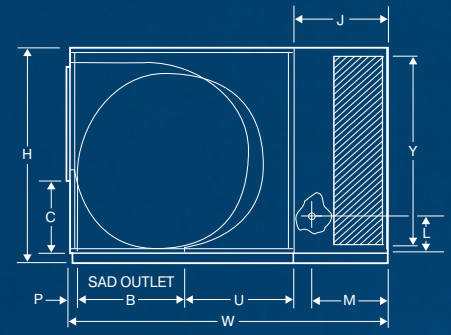

SIDE

DIMENSIONAL DATA (IN INCHES)

CABINET			DUCT OPENING			DUCT LOCATION			DRAIN LOCATION			WET MODULE		MEDIA DIMENSIONS		WATER SERVICE		ELECTRIC SERVICE		SOLID LOCATION		
H	W	D	A	B	C (SAS)	U (SAD)	P (SAD)	E	F	G	J	X	Y	L	M	S	T	N	Q	R		
44	67 $\frac{7}{8}$	45	21 $\frac{3}{4}$	21 $\frac{3}{4}$	13 $\frac{19}{32}$	21 $\frac{11}{32}$	1 $\frac{29}{32}$	11 $\frac{1}{8}$	22 $\frac{1}{2}$	16 $\frac{1}{2}$	22 $\frac{1}{2}$	44 $\frac{3}{4}$	36 $\frac{3}{8}$	5 $\frac{7}{8}$	18 $\frac{3}{8}$	21 $\frac{1}{2}$	5 $\frac{5}{8}$	4 $\frac{3}{4}$	4 $\frac{3}{4}$	42		

PUMP SPECIFICATIONS/BLOWER & WET MODULE PART NUMBERS

PUMP PART #	VOLTS	AMPS	WATTS	GPM (5FT. HEAD)	SIDE DRAFT BLOWER MODULE	DOWN DRAFT BLOWER MODULE	WET MODULE
110467	115	1	73	4.6	SAS100B	SAD100B	SAS/SAD10012W (one pump required)
110468	230	0.58	77	4.6	SAS100B	SAD100B	SAS/SAD10012W (one pump required)

SPECIFICATIONS

PERFORMANCE Certified air delivery at .1 increments of external static pressure (inches static pressure water gauge)

MAX BHP	OPER WGT (LBS)	SAD MODEL BELT	SAS MODEL BELT	0		0.1		0.2		0.3		0.4		0.5		0.6		0.7		0.8		0.9		1.0	
				CFM	RPM	CFM	RPM	CFM	RPM	CFM	RPM	CFM	RPM	CFM	RPM	CFM	RPM	CFM	RPM	CFM	RPM	CFM	RPM	CFM	RPM
3/4	527	B77	B83	5371	362	5064	374	4794	386	4536	397	4269	410	3985	423	3667	439	3318	458	2952	481	2591	507	2261	534
1	530	B77	B83	5911	359	5627	410	5375	420	5142	431	4907	441	4663	453	4399	465	4115	479	3809	495	3480	514	3145	536
1 1/2	545	B77	B83	6767	457	6513	466	6286	475	6076	484	5872	494	5666	503	5456	513	5238	523	5008	534	4755	546	4497	560

The performance certified is for installation type B-Free inlet, ducted outlet. The power rating (BHP) does not include transmission losses. Performance ratings do not include the effects of appurtenances (accessories). Models include the effects of an appropriate evaporative media on the inlet.

MOTOR SPECIFICATIONS

BLOWER MOTORS				PHASE	MOTOR AMPS	SHAFT DIA (INCHES)	MOTOR WGT (LBS)	MOTOR PART	BLOWER MOTORS				PHASE	MOTOR AMPS	SHAFT DIA (INCHES)	MOTOR WGT (LBS)	MOTOR PART
HP	SPEED	VOLTS	HP						SPEED	VOLTS							
3/4	1	115/208 - 230	1	13.8/7.6-6.9	5/8	24	110455	1	2	230	1	8	5/8	29	110458		
3/4	2	230	1	6.9	5/8	29	110480	1	1	208-230/460	3	4.8-4.2/2.1	7/8	34	110462-9		
3/4	1	208-230/460	3	3.5-3.2/1.6	5/8	20	110461	1 1/2	1	115/208-230	1	20/11-10	5/8	41	110459-1		
1	1	115/230	1	16/8	5/8	28	110457	1 1/2	1	208-230/460	3	6.9-6/3	7/8	40	110463-9		

SHEAVE SELECTION

MOTOR HP	MAUREY SHEAVE	SHEAVE BORE (IN INCHES)	SAD MODEL BELT	SAS MODEL BELT	BLOWER RPM/MOTOR SHEAVE 1/2 TURN DOWN												SAD PULLEY-BELT KIT #	SAS PULLEY-BELT KIT #
					12	11	10	9	8	7	6	5	4	3	2	1		
3/4, 1	8350K	5/8	B77	B83	303	313	323	333	343	353	364	374	384	394	404	414	3DI-90	3DI-110
3/4, 1, 1 1/2	8450K	5/8	B77	B83	414	424	434	445	455	465	475	485	495	506	516	526	3DI-95	3DI-115
1	8350	7/8	B77	B83	303	313	323	333	343	353	364	374	384	394	404	414	3DI-100	3DI-120
1, 1 1/2	8450K	7/8	B77	B83	414	424	434	445	455	465	475	485	495	506	516	526	3DI-105	3DI-125

SIZING TABLES

3/4 HP MOTOR/CFM-SP

1 HP MOTOR/CFM-SP

1 1/2 HP MOTOR/CFM-SP

OUTDOOR DRY BULB TEMP	OUTDOOR WET BULB TEMP																											
	5371/00			3985/.5			2261/1.0			5911/0			4663/.5			3145/1.0			6767/0			5666/.5			4497/1.0			
	75°	65°	55°	75°	65°	55°	75°	65°	55°	75°	65°	55°	75°	65°	55°	75°	65°	55°	75°	65°	55°	75°	65°	55°	75°	65°	55°	
85°	LAT	76	67	58	76	67	58	76	66	57	76	67	58	76	67	58	76	67	58	76	67	59	76	67	58	76	67	58
	GPH	6	12	17	6	12	13	2	5	7	6	13	19	6	13	19	5	10	16	7	14	22	6	12	18	5	10	15
95°	LAT	77	68	59	77	68	59	76	67	58	77	68	59	77	68	59	77	68	58	77	69	60	77	68	60	77	68	59
	GPH	12	17	23	12	17	23	5	7	9	13	19	25	10	15	20	7	10	13	14	22	29	12	18	25	10	15	19
105°	LAT	78	69	-	78	69	-	77	68	-	78	69	-	78	68	-	78	68	-	79	70	-	78	70	-	78	69	-
	GPH	17	23	-	12	16	-	7	9	-	19	25	-	15	20	-	10	13	-	22	29	-	18	25	-	15	19	-
115°	LAT	79	70	-	79	70	-	78	68	-	79	71	-	79	70	-	78	69	-	80	71	-	80	71	-	79	70	-
	GPH	23	29	-	16	20	-	9	11	-	25	32	-	20	25	-	13	16	-	29	36	-	25	31	-	19	24	-

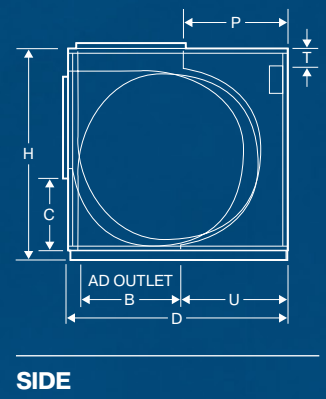
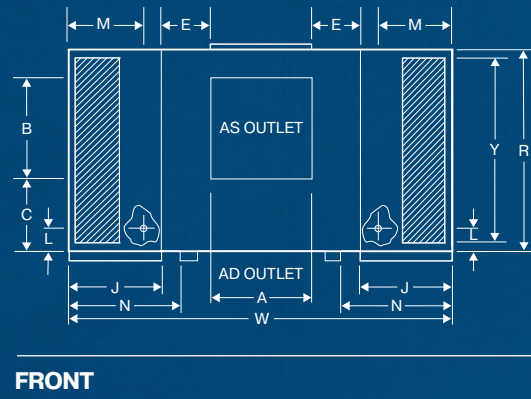
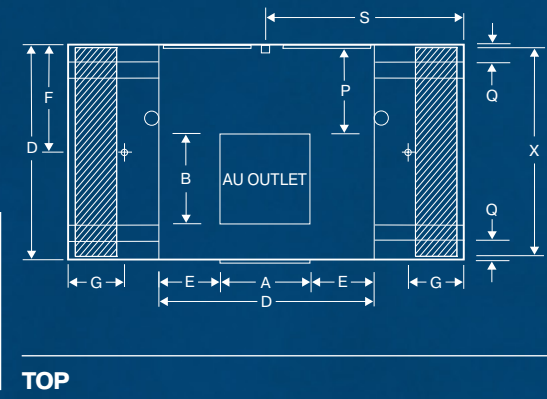

DIMENSIONAL DATA (IN INCHES)

CABINET			DUCT OPENING			DUCT LOCATION			DRAIN LOCATION		WET MODULE	MEDIA DIMENSIONS		WATER SERVICE		ELECTRIC SERVICE		SOLID LOCATION		
H	W	D	A	B	C (AS)	U (AD)	P (AU)	E	F	G	J	X	Y	L	M	S	T	N	Q	R
54	85 1/4	48 1/4	26 7/8	26 7/8	16 13/16	19 3/32	-	10 1/16	24 1/8	12 1/2	18 1/2	48	46 3/8	5 7/8	14 3/8	41 1/2	5 3/32	23 1/4	4 3/8	52

PUMP SPECIFICATIONS/BLOWER & WET MODULE PART NUMBERS

PUMP PART #	VOLTS	AMPS	WATTS	GPM (5FT. HEAD)	SIDE DRAFT BLOWER MODULE		DOWN DRAFT BLOWER MODULE		WET MODULE	
					AS150B	AD150B	AS/AD150W (two pumps required)			
110467	115	1	73	4.6						
110468	230	0.58	77	4.6						

SPECIFICATIONS

PERFORMANCE Certified air delivery at .1 increments of external static pressure (inches static pressure water gauge)

MAX BHP	OPER WGT (LBS)	AD MODEL BELT	AS MODEL BELT	0		0.1		0.2		0.3"		0.4		0.5		0.6		0.7		0.8		0.9"		1.0	
				CFM	RPM	CFM	RPM	CFM	RPM	CFM	RPM	CFM	RPM	CFM	RPM	CFM	RPM	CFM	RPM	CFM	RPM	CFM	RPM	CFM	RPM
2	854	B90	B96	11405	317	10892	382	10463	338	10064	347	9671	357	9276	367	8874	378	8456	390	8006	403	7530	418	7017	436
3	867	B92	B100	13057	363	12600	373	12204	381	11844	390	11497	398	11153	406	10815	415	10467	424	10113	434	9741	444	9361	456
5	883	B93	B100	15480	430	15082	439	14735	446	14410	454	14106	461	13810	468	13520	475	13234	482	12948	489	12659	496	12361	504
7 1/2	919	B95	B101	17719	492	17364	500	17050	507	16756	513	16479	520	16214	526	15947	532	15694	538	15440	544	15188	550	14937	557

The performance certified is for installation type B-Free inlet, ducted outlet. The power rating (BHP) does not include transmission losses. Performance ratings do not include the effects of appurtenances (accessories). Models include the effects of an appropriate evaporative media on the inlet.

MOTOR SPECIFICATIONS

BLOWER MOTORS								BLOWER MOTORS							
HP	SPEED	VOLTS	PHASE	MOTOR AMPS	SHAFT DIA (INCHES)	MOTOR WGT (LBS)	MOTOR PART	HP	SPEED	VOLTS	PHASE	MOTOR AMPS	SHAFT DIA (INCHES)	MOTOR WGT (LBS)	MOTOR PART
2	1	115/208 - 230	1	24/13.2-12	5/8	49	110460-1	5	1	208 - 230/460	3	17.5-15.2/7.6	1 1/8	87	110466-9
2	1	208 - 230/460	3	7.8-6.8/3.4	7/8	44	110464-9	7 1/2	1	200	3	25	1 3/8	121	110470-92
3	1	208 - 230/460	3	11-9.6/4.8	1 1/8	83	110465-9	7 1/2	1	230/460	3	22/11	1 3/8	121	110470-9

SHEAVE SELECTION

MOTOR HP	MAUREY SHEAVE	SHEAVE BORE (IN INCHES)	AD MODEL BELT	AS MODEL BELT	BLOWER RPM/MOTOR SHEAVE 1/2 TURN DOWN																AD PULLEY-BELT KIT #	AS PULLEY-BELT KIT #
					12	11	10	9	8	7	6	5	4	3	2	1						
2	D8400	5/8	B90	B96	291	299	308	316	325	330	342	350	359	367	376	384	3DI-51	3DI-71				
2	D8450	5/8	B90	B96	347	356	364	371	381	390	398	407	415	424	432	441	3DI-53	3DI-73				
2	D8400	7/8	B90	B96	291	299	308	316	325	330	342	350	359	367	376	384	3DI-50	3DI-70				
2	D8450	7/8	B90	B96	347	356	364	373	381	390	398	407	415	424	432	441	3DI-52	3DI-72				
3	D8450	1 1/8	B92	B100	347	356	364	373	381	390	398	407	415	424	432	441	3DI-56	3DI-75				
5	D8550	1 1/8	B93	B100	403	412	420	429	437	446	454	463	471	480	488	497	3DI-60	3DI-80				
7 1/2	D8600	1 3/8	B95	B101	459	468	476	485	493	502	510	519	527	536	544	553	3DI-65	3DI-86				

SIZING TABLES

OUTDOOR DRY BULB TEMP	2 HP MOTOR/CFM-SP					3 HP MOTOR/CFM-SP					5 HP MOTOR/CFM-SP					7 1/2 HP MOTOR/CFM-SP																					
	11405/0		9276/.5		7017/1.0		13057/0		11153/.5		9361/1.0		15480/0		13810/0		12361/1.0		17719/0		16214/.5		14937/1.0														
	OUTDOOR WET BULB TEMP																																				
85°	LAT	77	69	61	77	68	60	77	68	59	77	69	61	77	69	60	77	69	61	77	70	62	77	70	62	77	69	62									
	GPH	11	22	33	9	18	27	7	14	21	13	26	38	11	22	33	9	18	27	15	30	46	14	27	41	12	24	36	17	34	51	16	32	48	15	29	44
95°	LAT	79	71	63	78	70	62	78	69	61	79	71	63	79	71	62	79	70	62	79	72	64	79	71	63	79	70	62	80	74	64	80	72	64	79	82	64
	GPH	23	33	45	18	27	36	14	21	27	26	38	51	22	33	44	18	27	37	30	46	61	27	41	54	24	36	49	34	51	68	32	48	63	29	44	58
105°	LAT	81	73	-	80	72	-	79	71	-	81	73	-	81	72	-	80	72	-	82	74	-	81	73	-	81	72	-	82	74	-	82	74	-	82	74	-
	GPH	33	45	-	27	36	-	21	27	-	38	51	-	33	44	-	27	37	-	46	61	-	41	54	-	36	49	-	51	68	-	48	63	-	44	58	-
115°	LAT	83	74	-	82	73	-	81	72	-	83	75	-	82	74	-	82	74	-	84	76	-	83	75	-	83	73	-	84	77	-	84	76	-	84	76	-
	GPH	45	56	-	36	46	-	27	35	-	51	64	-	44	55	-	37	46	-	61	76	-	54	68	-	49	60	-	68	85	-	63	79	-	58	73	-

SAS/SAD 150

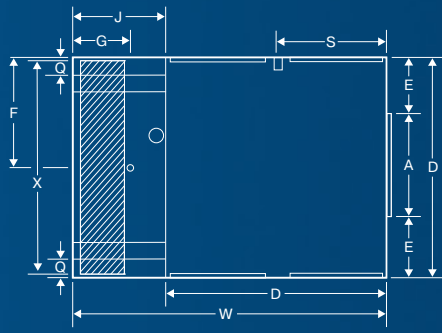

TOP

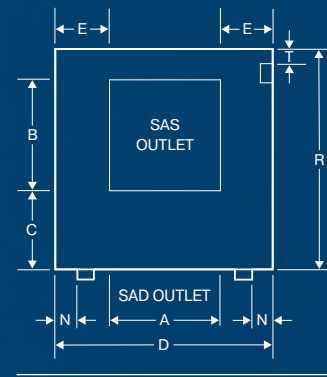

FRONT

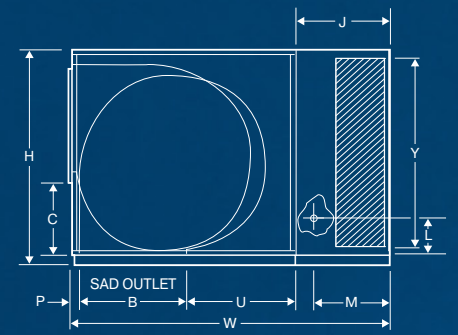

SIDE

DIMENSIONAL DATA (IN INCHES)

CABINET			DUCT OPENING			DUCT LOCATION			DRAIN LOCATION			WET MODULE		MEDIA DIMENSIONS		WATER SERVICE		ELECTRIC SERVICE		SOLID LOCATION		
H	W	D	A	B	C (SAS)	U (SAD)	P (SAD)	E	F	G	J	X	Y	L	M	S	T	N	Q	R		
54	66 5/8	48 1/4	26 7/8	26 7/8	16 1/16	19 5/32	2 7/32	10 11/16	24 1/8	12 1/2	18 1/2	48	46 3/8	5 7/8	14 5/8	23 1/8	5 5/32	4 3/4	4 3/4	52		

PUMP SPECIFICATIONS/BLOWER & WET MODULE PART NUMBERS

PUMP PART #	VOLTS	AMPS	WATTS	GPM (5FT. HEAD)	SIDE DRAFT BLOWER MODULE	DOWN DRAFT BLOWER MODULE	WET MODULE
110467	115	1	73	4.6	SAS150B	SAD150B	SAS/SAD150W (one pump required)
110468	230	0.58	77	4.6			

SPECIFICATIONS

PERFORMANCE Certified air delivery at .1 increments of external static pressure (inches static pressure water gauge)

MAX BHP	OPER WGT (LBS)	SAD MODEL BELT	SAS MODEL BELT	0		0.1		0.2		0.3		0.4		0.5		0.6		0.7		0.8		0.9		1.0	
				CFM	RPM	CFM	RPM	CFM	RPM	CFM	RPM	CFM	RPM	CFM	RPM	CFM	RPM	CFM	RPM	CFM	RPM	CFM	RPM	CFM	RPM
3/4	584	B90	B96	7072	275	6622	287	6203	298	5769	308	5298	321	4777	336	4201	355	3607	378	3041	402	2522	424	2040	443
1	593	B90	B96	7783	302	7372	314	6987	324	6602	333	6199	343	5764	355	5285	369	4764	386	4231	406	3699	427	3199	448
1 1/2	608	B90	B96	8910	346	8548	356	8205	365	7870	374	7533	382	7182	391	6812	401	6416	412	5993	424	5537	439	5067	456
2	612	B90	B96	-	-	9476	390	9159	399	8855	406	8555	414	8244	421	7924	430	7592	438	7236	448	6866	459	6470	471
3	624	B92	B100	-	-	-	-	-	-	-	-	-	-	-	-	-	-	9315	486	9032	493	8741	500	8436	509

The performance certified is for installation type B-Free inlet, ducted outlet. The power rating (BHP) does not include transmission losses. Performance ratings do not include the effects of appurtenances (accessories). Models include the effects of an appropriate evaporative media on the inlet.

MOTOR SPECIFICATIONS

BLOWER MOTORS				MOTOR SPECIFICATIONS				BLOWER MOTORS				MOTOR SPECIFICATIONS			
HP	SPEED	VOLTS	PHASE	MOTOR AMPS	SHAFT DIA (INCHES)	MOTOR WGT (LBS)	MOTOR PART	HP	SPEED	VOLTS	PHASE	MOTOR AMPS	SHAFT DIA (INCHES)	MOTOR WGT (LBS)	MOTOR PART
3/4	1	115/208-230	1	13.8/7.6-6.9	5/8	24	110455	1 1/2	1	115/208-230	1	20/11-10	5/8	41	110459-1
3/4	2	230	1	6.9	5/8	29	110480	1 1/2	1	208-230/460	3	6.9-6/3	7/8	40	110463-9
3/4	1	208-230/460	3	3.5-3.2/1.6	5/8	20	110461	2	1	115/208-230	1	24/13.2-12	5/8	49	110460-1
1	1	115/230	1	16/8	5/8	28	110457	2	1	208-230/460	3	7.8-6.8/3.4	7/8	44	110464-9
1	2	230	1	8	5/8	29	110458	3	1	208-230/460	3	11-9.6/4.8	1 1/8	83	110465-9
1	1	208-230/460	3	4.8-4.2/2.1	7/8	34	110462-9								

SHEAVE SELECTION

MOTOR HP	MAUREY SHEAVE	SHEAVE BORE (IN INCHES)	SAD MODEL BELT	SAS MODEL BELT	BLOWER RPM/MOTOR SHEAVE 1/2 TURN DOWN												SAD PULLEY-BELT KIT #	SAS PULLEY-BELT KIT #
					12	11	10	9	8	7	6	5	4	3	2	1		
3/4, 1	8350K	5/8	B90	B96	253	261	269	278	287	296	304	313	321	330	338	347	3DI-130	3DI-165
3/4, 1, 1 1/2, 2	8450K	5/8	B90	B96	347	356	364	373	381	390	398	407	415	424	432	441	3DI-135	3DI-170
2	8550	5/8	B90	B96	403	412	420	429	437	446	454	463	471	480	488	497	3DI-156	3DI-186
1	8350	7/8	B90	B96	253	261	269	278	287	296	304	313	321	330	338	347	3DI-140	3DI-175
1, 1 1/2, 2	8450K	7/8	B90	B96	347	356	364	373	381	390	398	407	415	424	432	441	3DI-145	3DI-180
1 1/2, 2	8550	7/8	B90	B96	403	412	420	429	437	446	454	463	471	480	488	497	3DI-155	3DI-185
3	8550	1 1/8	B92	B100	403	412	420	429	437	446	454	463	471	480	488	497	3DI-161	3DI-190

SIZING TABLES

OUTDOOR DRY BULB TEMP	3/4 HP MOTOR/CFM-SP					1 HP MOTOR/CFM-SP					1 1/2 HP MOTOR/CFM-SP					2 HP MOTOR/CFM-SP					3 HP MOTOR/CFM-SP																																																	
	7072/0					4777/.5					2040/1.0					7783/0					5764/.5					3199/1.0					8910/0					7182/.5					5067/1.0					9476/.1					8244/.5					6470/1.0					9315/.7					8436/1.0				
	OUTDOOR WET BULB TEMP																																																																					
85°	LAT	77	69	61	77	68	60	76	68	59	77	69	62	77	69	61	76	68	59	78	70	62	77	69	61	77	68	60	77	70	62	77	69	61	77	70	62	77	70	62	77	70	62																											
	GPH	7	14	21	5	9	14	2	5	7	8	15	23	6	11	17	3	7	10	8	17	25	7	14	20	5	9	14	9	17	26	8	15	23	6	12	18	9	17	26	8	15	23																											
95°	LAT	79	71	63	78	70	62	78	69	61	79	72	64	79	71	62	78	69	61	80	72	64	79	71	63	79	70	62	80	72	64	79	71	63	80	72	64	79	71	63	80	72	64	80	72	64																								
	GPH	14	21	28	9	14	18	5	7	9	15	23	30	11	17	22	7	10	14	17	25	34	14	20	27	9	14	19	17	26	34	15	23	31	12	18	24	17	26	34	15	23	31																											
105°	LAT	81	73	-	80	72	-	79	71	-	82	74	-	81	72	-	79	71	-	82	74	-	81	73	-	80	72	-	82	74	-	81	73	-	82	74	-	81	73	-	82	74	-	82	74	-																								
	GPH	21	28	-	14	18	-	7	9	-	23	30	-	17	22	-	10	14	-	25	34	-	20	27	-	14	19	-	26	34	-	23	31	-	18	24	-	26	34	-	23	31	-																											
115°	LAT	83	75	-	82	73	-	81	72	-	84	76	-	82	74	-	81	72	-	84	77	-	83	75	-	82	73	-	84	77	-	84	76	-	83	75	-	84	77	-	84	76	-	84	76	-																								
	GPH	28	35	-	18	23	-	9	11	-	30	38	-	22	28	-	14	17	-	34	42	-	27	34	-	19	23	-	34	43	-	31	39	-	24	30	-	34	43	-	31	39	-																											

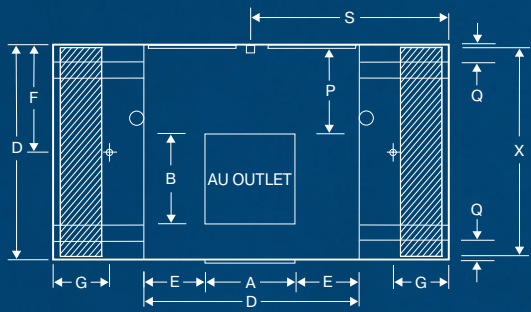

TOP

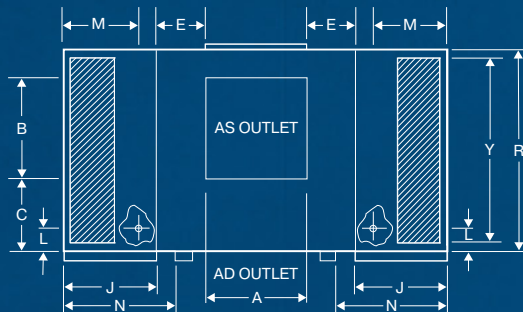

FRONT

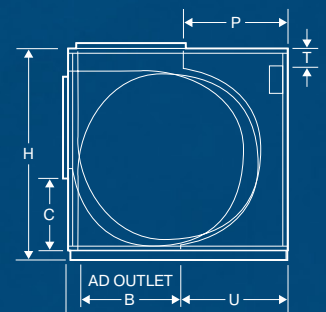

SIDE

DIMENSIONAL DATA (IN INCHES)

CABINET			DUCT OPENING			DUCT LOCATION			DRAIN LOCATION			WET MODULE		MEDIA DIMENSIONS		WATER SERVICE		ELECTRIC SERVICE		SOLID LOCATION		
H	W	D	A	B	C (AS)	U (AD)	P (AU)		E	F	G	J	X	Y	L	M	S	T	N	Q	R	
54	93 1/4	48 1/4	26 7/8	26 7/8	16 13/16	19 5/32	-		10 11/16	24 1/8	16 1/2	22 1/2	48	46 3/8	5 7/8	18 5/8	45 1/2	5 5/32	27 1/4	4 3/4	52	

PUMP SPECIFICATIONS/BLOWER & WET MODULE PART NUMBERS

PUMP PART #	VOLTS	AMPS	WATTS	GPM (5FT. HEAD)	SIDE DRAFT BLOWER MODULE		DOWN DRAFT BLOWER MODULE		WET MODULE	
110467	115	1	73	4.6	AS150B		AD150B		AS/AD15012W (two pumps required)	
110468	230	0.58	77	4.6						

SPECIFICATIONS

PERFORMANCE Certified air delivery at .1 increments of external static pressure (inches static pressure water gauge)

MAX BHP	OPER WGT (LBS)	AD MODEL BELT	AS MODEL BELT	0		0.1		0.2		0.3		0.4		0.5		0.6		0.7		0.8		0.9		1.0	
				CFM	RPM	CFM	RPM	CFM	RPM	CFM	RPM	CFM	RPM	CFM	RPM	CFM	RPM	CFM	RPM	CFM	RPM	CFM	RPM	CFM	RPM
2	967	B90	B96	11375	303	10905	314	10482	324	10079	335	9678	346	9265	365	8830	368	8366	380	7867	394	7352	409	6753	426
3	980	B92	B100	13020	346	12604	356	12225	365	11865	375	11514	384	11165	393	10807	403	10440	413	10058	423	9651	433	9220	445
5	996	B93	B100	15438	410	15084	419	14749	427	14434	435	14133	443	13838	450	13540	458	13246	466	12899	474	12640	482	12328	490
7 1/2	1032	B95	B101	17672	470	17360	477	17060	484	16777	491	16505	498	16242	505	15983	512	15724	519	15463	526	15207	532	14947	539

The performance certified is for installation type B-Free inlet, ducted outlet. The power rating (BHP) does not include transmission losses. Performance ratings do not include the effects of appurtenances (accessories). Models include the effects of an appropriate evaporative media on the inlet.

MOTOR SPECIFICATIONS

BLOWER MOTORS				SHAFT DIA (INCHES)	MOTOR WGT (LBS)	MOTOR PART	BLOWER MOTORS				SHAFT DIA (INCHES)	MOTOR WGT (LBS)	MOTOR PART		
HP	SPEED	VOLTS	PHASE				HP	SPEED	VOLTS	PHASE					
2	1	115/208 - 230	1	24/13.2-12	5/8	49	110460-1	5	1	208 - 230/460	3	17.5-15.2/7.6	1 1/8	87	110466-9
2	1	208 - 230/460	3	7.8-6.8/3.4	7/8	44	110464-9	7 1/2	1	200	3	25	1 1/8	121	110470-92
3	1	208 - 230/460	3	11-9.6/4.8	1 1/8	83	110465-9	7 1/2	1	230/460	3	22/11	1 1/8	121	110470-9

SHEAVE SELECTION

MOTOR HP	MAUREY SHEAVE	SHEAVE BORE (IN INCHES)	AD MODEL BELT	AS MODEL BELT	BLOWER RPM/MOTOR SHEAVE 1/2 TURN DOWN														AD PULLEY-BELT KIT #	AS PULLEY-BELT KIT #
					12	11	10	9	8	7	6	5	4	3	2	1				
2	D8400	5/8	B90	B96	291	299	308	316	325	333	342	350	359	367	376	384	3DI-51	3DI-71		
2	D8450	5/8	B90	B96	347	356	364	373	381	390	398	407	415	424	432	441	3DI-53	3DI-73		
2	D8400	7/8	B90	B96	291	299	308	316	325	333	342	350	359	367	376	384	3DI-50	3DI-70		
2	D8450	7/8	B90	B96	347	356	364	373	381	390	398	407	415	424	432	441	3DI-52	3DI-72		
3	D8450	1 1/8	B92	B100	347	356	364	373	381	390	398	407	415	424	432	441	3DI-56	3DI-75		
5	D8550	1 1/8	B93	B100	403	412	420	429	437	446	454	463	471	480	488	497	3DI-60	3DI-80		
7 1/2	D8600	1 3/8	B95	B101	459	468	476	485	493	502	510	519	527	536	544	553	3DI-65	3DI-86		

SIZING TABLES

OUTDOOR DRY BULB TEMP	2 HP MOTOR/CFM-SP					3 HP MOTOR/CFM-SP					5 HP MOTOR/CFM-SP					7 1/2 HP MOTOR/CFM-SP									
	11375/0					13020/0					15438/0					17672/.1									
	75°	65°	55°	75°	65°	55°	75°	65°	55°	75°	65°	55°	75°	65°	55°	75°	65°	55°	75°	65°	55°	75°	65°	55°	
85°	LAT	76	67	58	76	67	58	76	67	58	76	67	58	76	67	58	76	67	58	76	67	59	76	67	58
	GPH	12	25	37	10	20	30	8	15	23	14	28	42	12	24	36	10	20	30	16	33	49	15	30	45
95°	LAT	77	68	59	77	68	59	77	68	59	77	68	59	77	68	60	77	68	59	77	69	60	77	69	60
	GPH	25	37	49	20	30	40	15	23	30	28	42	56	24	36	48	20	30	40	33	49	66	30	45	59
105°	LAT	78	69	-	78	68	-	77	68	-	78	69	-	78	69	-	78	70	-	78	69	-	79	70	-
	GPH	37	49	-	30	40	-	23	30	-	42	59	-	36	48	-	30	40	-	49	66	-	45	59	-
115°	LAT	79	70	-	79	70	-	78	69	-	79	70	-	79	70	-	79	70	-	80	71	-	79	70	-
	GPH	49	61	-	40	51	-	30	38	-	56	70	-	48	60	-	40	50	-	66	82	-	59	74	-

SAS/SAD 15012

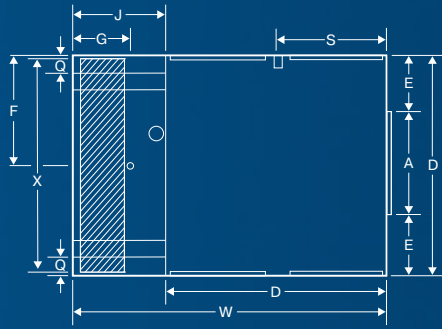

TOP

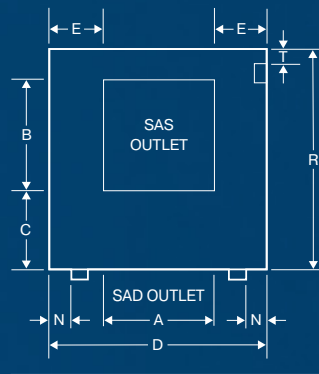

FRONT

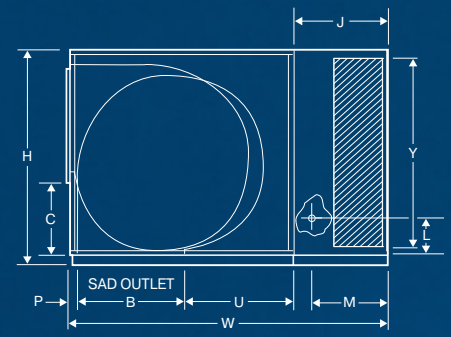

SIDE

DIMENSIONAL DATA (IN INCHES)

CABINET			DUCT OPENING			DUCT LOCATION			DRAIN LOCATION			WET MODULE		MEDIA DIMENSIONS		WATER SERVICE		ELECTRIC SERVICE		SOLID LOCATION		
H	W	D	A	B	C (SAS)	U (SAD)	P (SAD)	E	F	G	J	X	Y	L	M	S	T	N	Q	R		
54	70 3/4	48 1/4	26 3/4	26 3/4	16 1/2	19 1/2	2 3/4	10 1/16	24 1/8	16 1/2	22 1/2	48	46 3/8	5 7/8	18 3/8	23 1/8	5 1/2	4 3/8	4 3/8	52		

PUMP SPECIFICATIONS/BLOWER & WET MODULE PART NUMBERS

PUMP PART #	VOLTS	AMPS	WATTS	GPM (5FT. HEAD)	SIDE DRAFT BLOWER MODULE	DOWN DRAFT BLOWER MODULE	WET MODULE
110467	115	1	73	4.6	SAS150B	SAD150B	SAS/SAD15012W (one pump required)
110468	230	0.58	77	4.6	SAS150B	SAD150B	SAS/SAD15012W (one pump required)

SPECIFICATIONS

PERFORMANCE Certified air delivery at .1 increments of external static pressure (inches static pressure water gauge)

MAX BHP	OPER WGT (LBS)	SAD MODEL BELT	SAS MODEL BELT	0		0.1		0.2		0.3		0.4		0.5		0.6		0.7		0.8		0.9		1.0	
				CFM	RPM	CFM	RPM	CFM	RPM	CFM	RPM	CFM	RPM	CFM	RPM	CFM	RPM	CFM	RPM	CFM	RPM	CFM	RPM	CFM	RPM
3/4	645	B90	B96	6997	267	6539	278	6087	289	5603	301	5051	315	4415	332	3717	353	3058	376	2497	398	2013	419	1571	436
1	649	B90	B96	7702	294	7286	303	6876	314	6450	324	5994	336	5477	349	4893	364	4260	383	3637	404	3085	425	2609	444
1 1/2	665	B90	B96	8817	336	8455	345	8091	353	7734	363	7359	372	6961	382	6525	393	6050	405	5527	419	4976	435	4425	453
2	669	B90	B96	-	-	9375	378	9044	386	8719	394	8389	402	8043	411	7683	420	7293	430	6869	440	6416	452	5932	465
3	681	B92	B100	-	-	-	-	-	-	-	-	-	-	-	-	9377	466	9070	474	8751	482	8407	490	8046	499

The performance certified is for installation type B-Free inlet, ducted outlet. The power rating (BHP) does not include transmission losses. Performance ratings do not include the effects of appurtenances (accessories). Models include the effects of an appropriate evaporative media on the inlet.

MOTOR SPECIFICATIONS

BLOWER MOTORS				PHASE	MOTOR AMPS	SHAFT DIA (INCHES)	MOTOR WGT (LBS)	MOTOR PART	BLOWER MOTORS				PHASE	MOTOR AMPS	SHAFT DIA (INCHES)	MOTOR WGT (LBS)	MOTOR PART
HP	SPEED	VOLTS	VOLTS						SPEED	VOLTS							
3/4	1	115/208 - 230	1	13.8/7.6-6.9	5/8	24	110455	1 1/2	1	115/208 - 230	1	20/11-10	5/8	41	110459-1		
3/4	2	230	1	9.6	5/8	29	110480	1 1/2	1	208 - 230/460	3	6.9-6/3	7/8	40	110463-9		
3/4	1	208 - 230/460	3	3.5-3.2/1.6	5/8	20	110461	2	1	115/208-230	1	24/13.2-12	5/8	49	110460-1		
1	1	115/230	1	16/8	5/8	28	110457	2	1	208 - 230/460	3	7.8-6.8/3.4	7/8	44	110464-9		
1	2	230	1	8	5/8	29	110458	3	1	208-230/460	3	11-9.6/4.8	1 1/8	83	110465-9		
1	1	208 - 230/460	3	4.8-4.2/2.1	7/8	34	110462-9										

SHEAVE SELECTION

MOTOR HP	MAUREY SHEAVE	SHEAVE BORE (IN INCHES)	SAD MODEL BELT	SAS MODEL BELT	BLOWER RPM/MOTOR SHEAVE 1/2 TURN DOWN											SAD PULLEY-BELT KIT #	SAS PULLEY-BELT KIT #	
					12	11	10	9	8	7	6	5	4	3	2			1
3/4, 1	8350K	5/8	B90	B96	253	261	269	278	287	296	304	313	321	330	338	347	3DI-130	3DI-165
3/4, 1, 1 1/2, 2	8450K	5/8	B90	B96	347	356	364	373	381	390	398	407	415	424	432	441	3DI-135	3DI-170
2	8550	5/8	B90	B96	403	412	420	429	437	446	454	463	471	480	488	497	3DI-156	3DI-186
1	8350	7/8	B90	B96	253	261	269	278	287	296	304	313	321	330	338	347	3DI-140	3DI-175
1, 1 1/2, 2	8450K	7/8	B90	B96	347	356	364	373	381	390	398	407	415	424	432	441	3DI-145	3DI-180
1 1/2, 2	8550	7/8	B90	B96	403	412	420	429	437	446	454	463	471	480	488	497	3DI-155	3DI-185
3	8550	1 1/8	B92	B100	403	412	420	429	437	446	454	463	471	480	488	497	3DI-161	3DI-190

SIZING TABLES

OUTDOOR DRY BULB TEMP	3/4 HP MOTOR/CFM-SP					1 HP MOTOR/CFM-SP					1 1/2 HP MOTOR/CFM-SP					2 HP MOTOR/CFM-SP					3 HP MOTOR/CFM-SP							
	6997/0					7702/0					8817/0					9375/.1					9377/.6							
	4415/.5					5477/.5					6961/.5					8043/.5					5932/1.0							
OUTDOOR WET BULB TEMP																												
	75°	65°	55°	75°	65°	55°	75°	65°	55°	75°	65°	55°	75°	65°	55°	75°	65°	55°	75°	65°	55°	75°	65°	55°	75°	65°	55°	
85°	LAT	76	67	58	76	67	58	76	66	56	77	67	58	76	65	57	76	67	59	76	67	58	76	67	58	76	67	58
	GPH	8	15	23	4	9	13	2	4	5	8	16	25	6	12	18	3	6	9	9	19	28	7	15	22	5	10	15
95°	LAT	77	68	59	77	68	59	76	66	56	77	68	60	77	68	59	76	67	58	77	68	60	77	68	59	77	69	60
	GPH	15	23	30	10	14	19	4	5	7	16	25	33	12	18	24	6	9	12	19	28	37	15	22	30	10	15	19
105°	LAT	78	69	-	78	69	-	76	66	-	78	70	-	78	68	-	79	70	-	78	69	-	78	69	-	79	70	-
	GPH	23	30	-	14	19	-	5	7	-	25	33	-	18	24	-	9	12	-	28	37	-	22	30	-	15	19	-
115°	LAT	79	70	-	79	70	-	76	67	-	80	71	-	79	70	-	78	68	-	80	71	-	79	70	-	80	71	-
	GPH	30	38	-	19	24	-	7	9	-	33	41	-	24	30	-	12	15	-	37	47	-	30	37	-	19	24	-

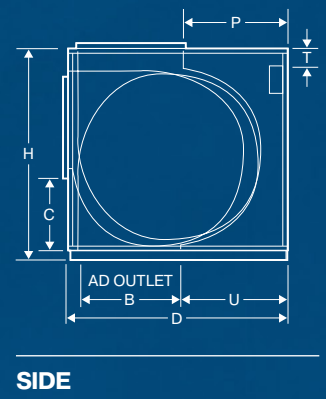
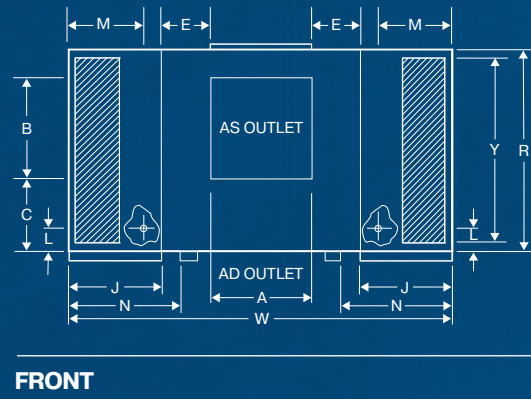
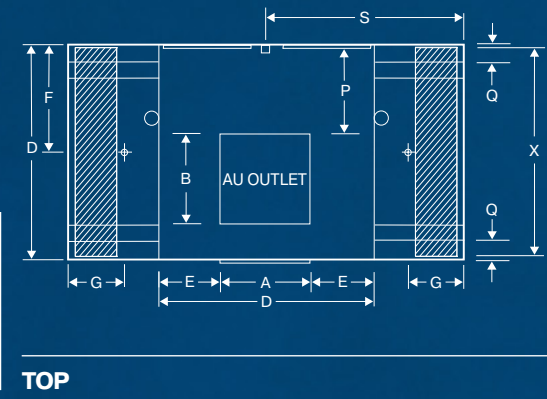

DIMENSIONAL DATA (IN INCHES)

CABINET			DUCT OPENING			DUCT LOCATION			DRAIN LOCATION			WET MODULE		MEDIA DIMENSIONS		WATER SERVICE		ELECTRIC SERVICE		SOLID LOCATION		
H	W	D	A	B	C (AS)	U (AD)	P (AU)	E	F	G	J	X	Y	L	M	S	T	N	Q	R		
59 1/4	105 1/4	60 1/4	31 3/4	31 3/4	18 11/16	25 1/8	24 29/32	14 1/4	30 1/8	16 1/8	22 1/2	60	51 1/8	5 7/8	18 5/8	51 1/8	5 3/32	4 3/4	4 3/4	57 1/4		

PUMP SPECIFICATIONS/BLOWER & WET MODULE PART NUMBERS

PUMP PART #	VOLTS	AMPS	WATTS	GPM (5FT. HEAD)	SIDE DRAFT BLOWER MODULE		DOWN DRAFT BLOWER MODULE		UP DRAFT BLOWER MODULE		WET MODULE	
					AS200B	AD200B	AU200B	AS/AD20012W (two pumps required)				
110467	115	1	73	4.6								
110468	230	0.58	77	4.6								

SPECIFICATIONS

PERFORMANCE Certified air delivery at .1 increments of external static pressure (inches static pressure water gauge)

MAX BHP	OPER WGT (LBS)	AD MODEL BELT	AS MODEL BELT	AU MODEL BELT	0		0.1		0.2		0.3		0.4		0.5		0.6		0.7		0.8		0.9		1.0	
					CFM	RPM	CFM	RPM	CFM	RPM	CFM	RPM	CFM	RPM	CFM	RPM	CFM	RPM	CFM	RPM	CFM	RPM	CFM	RPM	CFM	RPM
3	1249	B100	B112	B92	16267	276	15716	284	15200	292	14696	300	14190	308	13665	317	13110	325	12521	335	11886	346	11194	358	10450	371
5	1264	B100	B112	B92	19286	327	18820	334	18371	341	17943	348	17518	355	17092	361	16661	368	16211	375	15752	383	15272	390	14760	399
7 1/2	1297	B103	B112	B93	22077	374	21670	380	21270	387	20888	393	20514	399	20142	405	19769	410	19395	416	19015	422	18629	428	18229	435
10	1326	B103	B112	B93	24301	412	23929	417	23562	423	23204	429	22866	434	22528	440	22190	445	21852	450	21510	456	21171	461	20823	467

The performance certified is for installation type B-Free inlet, ducted outlet. The power rating (BHP) does not include transmission losses. Performance ratings do not include the effects of appurtenances (accessories). Models include the effects of an appropriate evaporative media on the inlet.

MOTOR SPECIFICATIONS

BLOWER MOTORS				VOLTS	PHASE	MOTOR AMPS	SHAFT DIA (INCHES)	MOTOR WGT (LBS)	MOTOR PART	BLOWER MOTORS				VOLTS	PHASE	MOTOR AMPS	SHAFT DIA (INCHES)	MOTOR WGT (LBS)	MOTOR PART
HP	SPEED									HP	SPEED								
3	1	208-230/460	3	11-9.6/4.8	1 1/8	83	110465-9	7 1/2	1	230/460	3	22/11	1 1/8	121	110470-9				
5	1	208-230/460	3	17.5-15.2/7.6	1 1/8	87	110466-9	10	1	200	3	32	1 1/8	138	110482-92				
7 1/2	1	200	3	25	1 1/8	121	110470-92	10	1	230/460	3	28/14	1 1/8	138	110482-9				

SHEAVE SELECTION

MOTOR HP	MAUREY SHEAVE	SHEAVE BORE (IN INCHES)	AD MODEL BELT	AS MODEL BELT	AU MODEL BELT	SHEAVE SELECTION										AD PULLEY-BELT KIT #	AS PULLEY-BELT KIT #	AU PULLEY-BELT KIT #	
						7	6 1/2	6	5 1/2	5	4 1/2	4	3 1/2	3	2 1/2				2
3	D8350	1 1/8	B100	B112	B92	253	262	272	281	291	300	309	319	328	338	347	3DI-195	3DI-210	3DI-225
5	D8400	1 1/8	B100	B112	B92	291	300	310	319	328	338	347	356	365	375	384	3DI-200	3DI-215	3DI-230
7 1/2	D8450	1 1/8	B103	B112	B93	347	358	369	381	392	403	414	425	437	448	459	3DI-203	3DI-218	3DI-233
10	D8550	1 1/8	B103	B112	B93	403	412	422	431	441	450	459	469	478	488	497	3DI-205	3DI-220	3DI-235

SIZING TABLES

OUTDOOR DRY BULB TEMP	3 HP MOTOR/CFM-SP					5 HP MOTOR/CFM-SP					7 1/2 HP MOTOR/CFM-SP					10 HP MOTOR/CFM-SP																																												
	16267/0					13655/.5					10450/1.0					19286/0					17092/.5					14760/1.0					22077/0					20142/.5					18229/1.0					24301/.0					22528/.5					20823/1.0				
	OUTDOOR WET BULB TEMP																																																											
85°	LAT	76	67	58	76	67	58	76	67	57	76	67	58	76	67	58	76	67	58	76	67	58	76	67	58	76	67	58	76	67	55	76	67	58	76	67	58	76	67	58																				
	GPH	18	36	54	15	31	46	12	24	35	21	42	63	19	38	56	17	33	49	24	48	72	22	44	66	20	40	60	27	53	79	25	49	74	23	46	68																							
95°	LAT	77	68	59	77	68	59	77	67	58	77	68	59	77	68	59	77	68	59	77	68	59	77	68	59	77	68	59	77	68	59	77	68	59	77	68	59	77	68	59																				
	GPH	36	54	72	31	46	61	24	35	47	43	64	84	38	57	75	33	49	66	49	72	96	45	67	88	41	61	80	53	80	106	50	74	98	46	69	91																							
105°	LAT	78	69	60	78	69	60	77	68	59	78	69	60	78	69	60	78	69	60	78	69	61	78	69	60	78	69	60	78	69	61	78	69	61	78	69	61	78	69	60																				
	GPH	54	72	90	46	61	76	36	47	59	64	85	106	57	76	94	50	66	82	73	97	120	67	89	110	61	81	100	80	106	123	74	99	123	69	92	114																							
115°	LAT	79	70	61	79	70	60	78	69	60	79	70	61	79	70	61	79	70	61	79	71	62	79	70	61	79	70	61	79	71	62	79	71	62	79	70	61	79	70	61																				
	GPH	72	90	107	62	77	91	48	49	71	85	106	127	76	95	113	66	82	98	97	121	144	89	111	133	81	101	121	107	133	147	99	123	147	92	115	137																							

AXIAL FAN ASSEMBLIES

FAD242B

FAD242BW8

FAD248B

FAD248BW8

Up To 21,000 CFM
42" and 48" axial fans for industrial cooling
From ¼ to 2 HP motors
8" Munters CELdek® Rigid Media



FEATURES

- GFCI Protected Pump Circuit*
- Plastic Reservoir and Media Shields Protect Cabinet from Water
- 1-Year Limited Warranty on Cabinet and Parts
- Limited Lifetime Warrant on Reservoir
- Bolted Cabinet for Easy Maintenance
- Fine Grid Intake Grille Helps Prevent Evaporative Media Plugging
- More Air Delivery Per HP than Centrifugal Blower Type Units
- Heavy-Gauge Galvanized Steel Cabinet



Champion Cooler Corporation certifies that the evaporative air coolers shown herein are licensed to bear the AMCA seal. The ratings shown are based on tests and procedures performed in accordance with AMCA publication 211 and comply with the requirements of the AMCA certified ratings program.

* A separate 120V, 60 Hz, 1-phase pump electric circuit is required to maintain the integrity of the GFCI pump protection and to maintain the UL listing of the evaporative cooler.

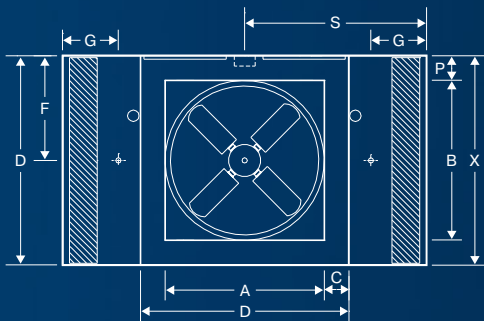

TOP

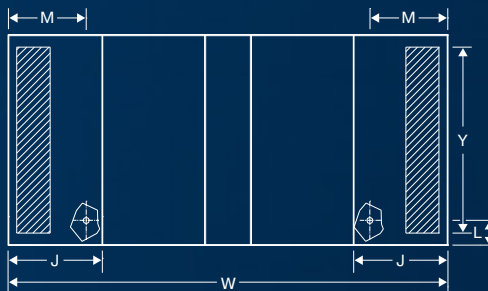

FRONT



SIDE

FAD242B/242BW8/248B/248BW8

DIMENSIONAL DATA (IN INCHES)

MODEL #	CABINET			DUCT OPENING		DUCT LOCATION		DRAIN LOCATION		WET MODULE	BOTTOM PAN RISER	MEDIA DIMENSIONS		WATER SERVICE		ELECTRIC SERVICE		APPROXIMATE WEIGHT (LBS)		APPROXIMATE TOTAL RESERVOIR CAPACITY
	H	W	D	A	B	C	P	F	G	J	U	X	Y	L	M	S	T	DRY	OPER	
FAD242B	40 1/8	97 1/4	60 1/4	46	46	7 1/8	7 1/8	30 1/8	12 1/2	18 1/2	6	60	34 1/2	5 7/8	14 5/8	48 5/8	4 3/4	720	1000	30 Gallons
FAD248B	50 1/8	97 1/4	60 1/4	52	52	4 1/8	4 1/8	30 1/8	12 1/2	18 1/2	6	60	44 1/2	5 7/8	14 5/8	48 5/8	14 3/4	780	1060	30 Gallons

SPECIFICATIONS

AXIAL FAN SECTIONS

AN AXIAL FAN ASSEMBLY IS MADE UP OF FOUR SEPARATE SECTIONS THAT MUST BE ORDERED INDIVIDUALLY: BLOWER SECTION, WET SECTION, MOTOR, AND PULLEY

BLOWER SECTION MODEL #

FAD242B

BLOWER SECTION SHIPPING WEIGHT

375 LBS



WET SECTION MODEL #

FAD242W8

WET SECTION SHIPPING WEIGHT

305 LBS

**Shipped disassembled; factory assembly available for an additional charge*

BLOWER SECTION MODEL #

FAD248B

BLOWER SECTION SHIPPING WEIGHT

400 LBS



WET SECTION MODEL #

FAD248W8

WET SECTION SHIPPING WEIGHT

340 LBS

**Shipped disassembled; factory assembly available for an additional charge*

FACTORY ASSEMBLED MODEL

MOTOR

CFM AT EXTERNAL STATIC PRESSURE (INCH WC)

MOTOR PULLEY PART

	HP	VOLTS	AMPS	PHASE	PART #	0	0.1	0.2	
FAD242B3411 (115V) OR FAD242B3412 (230V)	3/4	115/208-230	13.8/7.6-6.9	1	110455	12611	10259	6820	583022
FAD242B3432 (230V) OR FAD242B3434 (460V)	3/4	208-230/460	3.5-3.2/1.6	3	110461-1	12611	10259	6820	583022
FAD242B111 (115V) OR FAD242B112 (230V)	1	115/208-230	16/8	1	110457	13906	11869	7714	110308
FAD242B132 (230V) OR FAD242B134 (460V)	1	208-230/460	4.6-4.2/2.1	3	110462-1	13906	11869	7714	110308
FAD242B1511 (115V) OR FAD242B1512 (230V)	1 1/2	115/208-230	20/11-10	1	110459-1	15888	14085	11974	110308
FAD242B1532 (230V) OR FAD242B1534 (460V)	1 1/2	208-230/460	6.6-6/3	3	110463-1	15888	14085	11974	110308
FAD242B211 (115V) OR FAD242B212 (230V)	2	115/208-230	24/13.2-12	1	110483	17550	15973	14122	110279-003
FAD242B232 (230V) OR FAD242B234 (460V)	2	208-230/460	7.5-6.8/3.4	3	110464-1	17550	15973	14122	110279-003
FAD248B3411 (115V) OR FAD248B3412 (230V)	3/4	115/208-230	13.8/7.6-6.9	1	110455	15198	12523	-	583022
FAD248B3432 (230V) OR FAD248B3434 (460V)	3/4	208-230/460	3.5-3.2/1.6	3	110461-1	15198	12523	-	583022
FAD248B111 (115V) OR FAD248B112 (230V)	1	115/208-230	16/8	1	110457	16730	14324	-	110308
FAD248B132 (230V) OR FAD248B134 (460V)	1	208-230/460	4.6-4.2/2.1	3	110462-1	16730	14324	-	110308
FAD248B1511 (115V) OR FAD248B1512 (230V)	1 1/2	115/208-230	20/11-10	1	110459-1	19149	17078	14636	110279-003
FAD248B1532 (230V) OR FAD248B1534 (460V)	1 1/2	208-230/460	6.6-6/3	3	110463-1	19149	17078	14636	110279-003
FAD248B211 (115V) OR FAD248B212 (230V)	2	115/208-230	24/13.2-12	1	110483	21096	19563	18031	110279-003
FAD248B232 (230V) OR FAD248B234 (460V)	2	208-230/460	7.5-6.8/3.4	3	110464-1	21096	19563	18031	110279-003

The performance certified is for installation type B-Free inlet, ducted outlet. The power rating (BHP) does not include transmission losses. Performance ratings do not include the effects of appurtenances (accessories). Models include the effects of an appropriate evaporative media on the inlet.



MCB-02.2019